

# SiWN917 NCP Single Chip Wi-Fi® and Bluetooth® LE Wireless Secure Solutions Data Sheet

Silicon Labs' SiWN917 Network Connectivity Processor (NCP) is a comprehensive multi-protocol wireless sub-system. It has an integrated built-in wireless subsystem, advanced security, and integrated power-management. It has a multi-threaded Network Wireless Processor (NWP) running up to 160 MHz. All the networking and wireless stacks run on independent threads. The wireless subsystem integrates baseband digital signal processing, analog front-end, calibration eFuse, 2.4 GHz RF transceiver and integrated power amplifier thus providing a fully-integrated solution for a range of embedded wireless applications.

SiWN917 applications include:

- Smart Home
- Security Cameras
- HVAC
- Smart Sensors
- Smart Appliances
- Health and Fitness
- Pet Tracker
- Smart Cities
- Smart Meters
- Industrial Wearable
- Smart Buildings
- Asset Tracking
- Smart hospitals

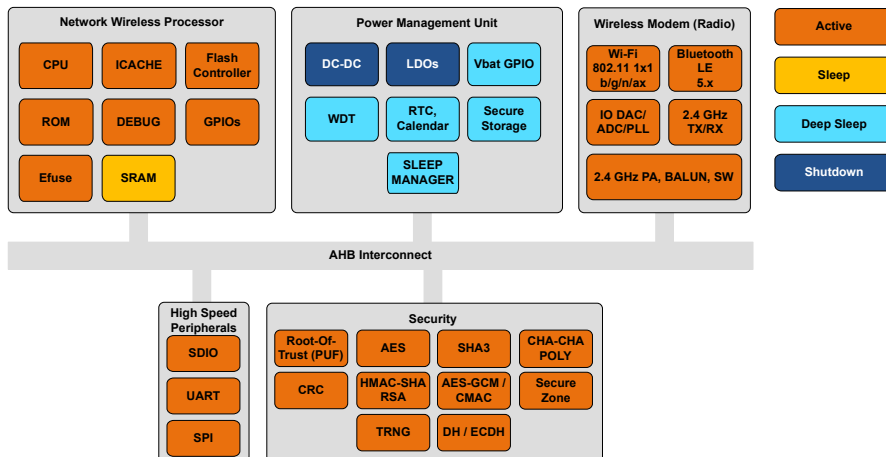

## KEY FEATURES

- Wi-Fi 6 Single Band 2.4 GHz 20 MHz 1x1 stream IEEE 802.11 b/g/n/ax
- Bluetooth LE 5.4
- Wi-Fi 6 Benefits: TWT for improved efficiency and longer battery life, DL MU-MIMO, DL/UL OFDMA for Higher Throughput, network capacity and low latency
- Best in Class Device and Wireless Security
- WLAN Tx power up to +19.5 dBm with integrated PA
- Bluetooth LE Tx power up to +19 dBm with integrated PA
- WLAN Rx sensitivity as low as -97.5 dBm
- Wi-Fi standby associated mode current: 65  $\mu$ A @ 1-second beacon listen interval
- In-package Flash up to 4 MB
- Embedded Wi-Fi, Bluetooth LE and networking stacks supporting wireless coexistence
- Operating temperature: -40 °C to +85 °C
- Single or dual-supply operation:
  - Single supply: 3.3 V
  - Dual supply: 3.3 V and 1.8 V

## 1. Feature List

- **Memory**
  - Embedded Static Random Access Memory (SRAM) up to 672 KB total
  - Flash up to 4 MB (in-package)
- **Security**
  - Secure Boot
  - Secure firmware upgrade through boot-loader, Secure OTA.
  - Secure Key storage and HW device identity with PUF
  - Secure Zone
  - Encrypted XiP (Execute in place) from flash
  - Secure Attestation
  - Hardware Accelerators: Advanced Encryption Standard (AES) 128/256/192, Secure Hash Algorithm (SHA) 256/384/512, Hash Message Authentication Code (HMAC), Random Number Generator (RNG), Cyclic Redundancy Check (CRC), SHA3, AES-Galois Counter Mode (GCM)/ Cipher based Message Authentication Code (CMAC), Cha-Cha-poly, True Random Number Generator (TRNG)
  - Software Implementation: RSA, ECC
  - Anti Rollback
  - Debug Lock
- **Wi-Fi**
  - Compliant to single-spatial stream IEEE 802.11 b/g/n/ax with single band (2.4 GHz) support
  - Support for 20 MHz channel bandwidth for 802.11n and 802.11ax
  - Operating Modes: Wi-Fi 4 STA, Wi-Fi 6 (802.11ax) STA, Wi-Fi 4 AP, Enterprise STA, Wi-Fi 6 STA + Wi-Fi 4 AP, Wi-Fi STA + BLE
  - Support for 802.11ax 20 MHz non-AP STA mandatory features (such as OFDMA, MU-MIMO) and optional features of individual Target wake-up time (iTWT), Broadcast TWT (bTWT)<sup>2</sup>, Intra PPDU power save<sup>2</sup>, SU extended range (ER), DCM (Dual Carrier Modulation), DL MU-MIMO, DL/UL OFDMA, MBSSID<sup>2</sup>, BFRP, Spatial Reuse<sup>2</sup>, BSS Coloring<sup>2</sup>, and NDP feedback up to 4 antennas
  - Transmit power up to +19.5 dBm with integrated PA
  - Receive sensitivity as low as -97.5 dBm
  - Data Rates: 802.11b: 1, 2, 5.5, 11; 802.11g: 6, 9, 12, 18, 24, 36, 48, 54 Mbps ; 802.11n: MCS0 to MCS7; 802.11ax: MCS0 to MCS7
  - Operating Frequency Range: 2412 MHz – 2484 MHz
  - PTA Coexistence with Zigbee/Thread/Bluetooth
- **Intelligent Power Management**
  - Power optimizations leveraging multiple power domains and partitioned subsystems
  - Many system-, component-, and circuit-level innovations and optimizations
  - Multiple Power Modes
  - Deep sleep mode with only timer active – with and without RAM retention
- **Host Interface Peripherals**
  - SPI - up to 100 MHz
  - SDIO<sup>2</sup> - up to 50 MHz
  - UART - up to 921600 Baud
- **Bluetooth**
  - Transmit power up to +19 dBm with integrated PA
  - Receive sensitivity — LE 1 Mbps: -96 dBm, LR 125 kbps: -107 dBm
  - Operating Frequency Range — 2.402 GHz - 2.480 GHz
  - Support LE (1 Mbps & 2 Mbps) and LR (125 kbps & 500 kbps) rates
  - Advertising extensions
  - Data length extensions
  - LL privacy
  - LE dual role
  - BLE acceptlist
  - 2 Simultaneous BLE Connections (2 Peripheral, 2 Central, or 1 Central & 1 Peripheral)
- **RF Features**
  - Integrated baseband processor with calibration memory
  - Integrated RF transceiver, high-power amplifier, balun and T/R switch
- **Embedded Wi-Fi Stack**
  - Support for Embedded Wi-Fi STA mode, Wi-Fi Access point mode and Concurrent (AP+STA) mode
  - Supports advanced Wi-Fi Security features: WPA Personal, WPA2 Personal, WPA3 Personal, WPA/WPA2/WPA3 Enterprise in STA mode
  - Networking: Integrated IPv4/IPv6 stack, TCP, UDP, ICMP, ICMPv6, ARP, DHCP Client/Server, DHCPv6 Client/Server, DNS Client, SSL3.0/TLS1.3 Client, SNTTP, mDNS, SNI
  - Applications: HTTP/s Client, HTTP/s Server<sup>2</sup>, MQTT/s Client, AWS Client, Azure Client
  - Sockets: BSD Sockets, IoT Sockets
  - Over-the-Air (OTA) firmware update
  - Provisioning using Wi-Fi AP or BLE
- **Embedded Bluetooth Stack**
  - Support GAP profile
  - Support GATT profile
  - Support SMP
  - Support LE L2CAP
- **Wireless Sub-System Power Consumption**
  - Wi-Fi 4 Standby Associated mode current: 65 µA @ 1-second beacon listen interval
  - Wi-Fi 1 Mbps Listen current: 16.5 mA
  - Wi-Fi LP chain Rx current: 22 mA
  - Deep sleep current ~2.5 µA, Standby current (352 KB RAM retention) ~10 µA
- **Operating Conditions**
  - Single or dual-supply operation:
    - Single supply: 3.3 V
    - Dual supply: 3.3 V and 1.8 V
  - Operating temperature: -40 °C to +85 °C

- **Software and Regulatory Certifications**

- Wi-Fi Alliance: Wi-Fi 4, Wi-Fi 6
- Bluetooth 5.4 Qualification
- Verified for compliance with FCC, ISED, CE, UKCA, MIC regulatory requirements<sup>1</sup>

**Note:**

1. For latest compliance information, refer to [AN1437](#) regulatory app note.
2. For information about software roadmap features, and lists of available features and profiles, contact Silicon Labs or refer to Release Notes and Reference Manuals.

## 2. Ordering Information

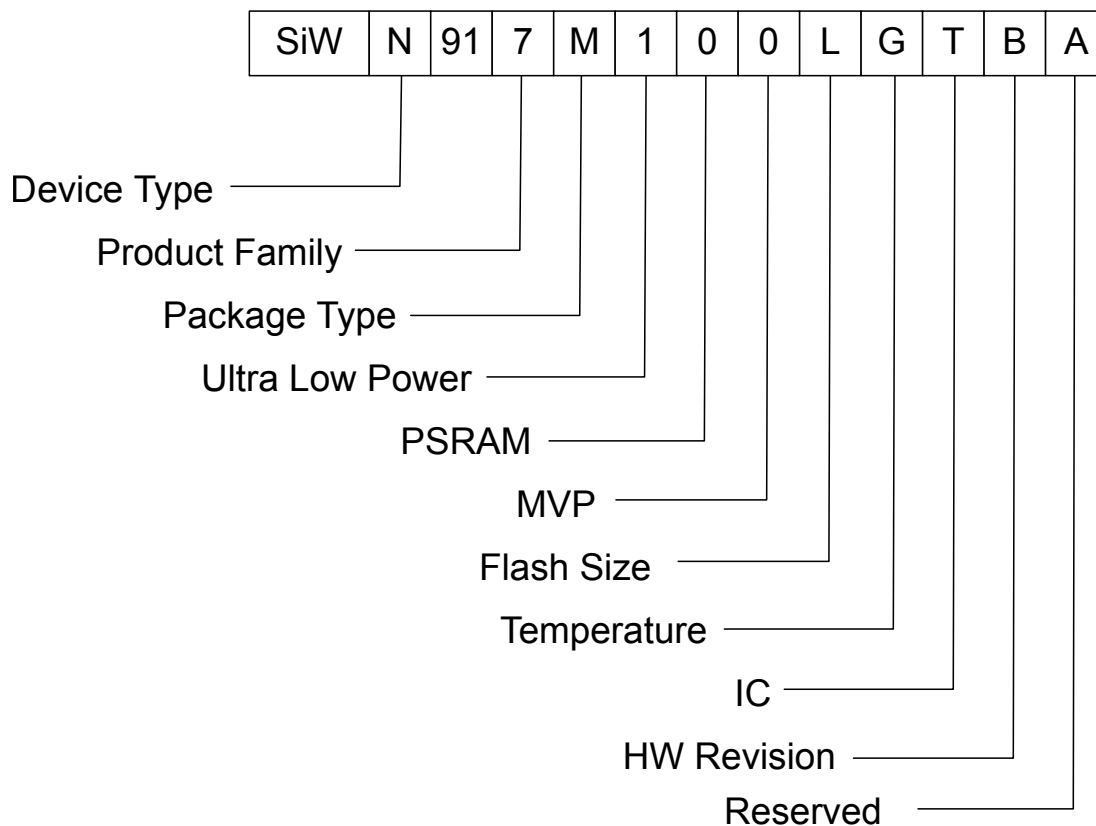

Figure 2.1. Ordering Guide

Table 2.1. OPN Decoder

Field	Options
Device Type	<b>T</b> : RCP ( Transceiver) <b>N</b> : NCP <b>G</b> : SoC
Product Family	<b>7</b> : Ultra-low power <b>5</b> : Ultra-low cost
Package Type	<b>M</b> : DR-QFN
Ultra Low Power	<b>0</b> : ULP Features disabled <b>1</b> : ULP Features enabled
PSRAM	<b>0</b> : No PSRAM Support <b>1</b> : External PSRAM <b>2</b> : 2 MB In-Package PSRAM <b>4</b> : 8 MB In-Package PSRAM
MVP	<b>0</b> : MVP Features disabled <b>1</b> : MVP Features enabled

Field	Options
Flash Size	<b>X</b> : No In-Package Flash <b>L</b> : 4 MB In-Package Flash <b>M</b> : 8 MB In-Package Flash
Temperature	<b>G</b> : -40 °C to 85 °C
IC/Module	<b>T</b> : IC Package
HW Revision	<b>B</b> : Revision B
Reserved	<b>A</b> : Reserved

Table 2.2. List of OPNs

Part Number	Common Features	Device Type	Flash Size	Temperature
SiWN917M100LGTA	Wi-Fi 6 Ultra low power IC, 7x7 DR-QFN, Integrated 2.4 GHz Radio	NCP	4 MB In-Package Flash	-40 to 85 °C
<b>Note:</b>				
1. Devices are shipped without firmware loaded. For custom parts with pre-loaded firmware, please contact Silicon Labs.				

# Table of Contents

<b>1. Feature List</b>	<b>2</b>
<b>2. Ordering Information</b>	<b>4</b>
<b>3. Applications.</b>	<b>9</b>
<b>4. Block Diagrams</b>	<b>10</b>
<b>5. System Overview</b>	<b>12</b>
5.1 Introduction	.12
5.2 WLAN.	.12
5.2.1 MAC	.12
5.2.2 Baseband Processing	.12
5.3 Bluetooth.	.12
5.3.1 MAC	.13
5.3.2 Baseband Processing	.13
5.4 RF Transceiver.	.13
5.4.1 Receiver and Transmitter Operating Modes	.14
5.5 Host Interfaces.	.14
5.5.1 Auto Host Detection	.14
5.6 Security Features	.14
5.7 Embedded Wi-Fi Software	.14
5.7.1 Security	.15
5.8 Power Architecture	.15
5.8.1 Highlights	.15
5.8.2 System Power Supply Configurations	.15
5.8.3 Power Management	.15
5.9 Memory Architecture	.16
5.10 Low Power Modes	.16
5.10.1 ULP Mode	.16
<b>6. Pinout and Pin Description</b>	<b>17</b>
6.1 Pin Diagram.	.17
6.2 Pin Description.	.18
6.2.1 RF and Control Interfaces	.18
6.2.2 Power and Ground Pins.	.19
6.2.3 Peripheral Interfaces	.20
6.2.4 Miscellaneous Pins	.26
<b>7. Electrical Specifications</b>	<b>28</b>
7.1 Absolute Maximum Ratings	.28
7.2 Recommended Operating Conditions	.29
7.3 DC Characteristics	.30
7.3.1 RESET_N and POC_IN Pins	.30

7.3.2	Power On Control (POC) and Reset	.31
7.3.3	ULP Regulators	.32
7.3.4	Power Management Unit	.33
7.3.5	Thermal Characteristics	.35
7.3.6	Digital I/O Signals.	.35
7.4	AC Characteristics	.36
7.4.1	Clock Specifications	.36
7.4.2	SDIO 2.0 Secondary	.38
7.4.3	HSPI Secondary	.39
7.4.4	UART	.41
7.4.5	GPIO Pins	.41
7.4.6	In-Package Flash Memory	.42
7.5	RF Characteristics	.42
7.5.1	WLAN 2.4 GHz Transmitter Characteristics	.43
7.5.2	WLAN 2.4 GHz Receiver Characteristics on HP RF Chain	.44
7.5.3	WLAN 2.4 GHz Receiver Characteristics on LP RF Chain	.46
7.5.4	Bluetooth Transmitter Characteristics on High-Performance (HP) RF Chain	.48
7.5.5	Bluetooth Transmitter Characteristics on Low-Power (LP) 8 dBm RF Chain	.49
7.5.6	Bluetooth Transmitter Characteristics on Low-Power (LP) 0 dBm RF Chain	.50
7.5.7	Bluetooth Receiver Characteristics for 1 Mbps Data Rate	.51
7.5.8	Bluetooth Receiver Characteristics for 2 Mbps Data Rate	.53
7.5.9	Bluetooth Receiver Characteristics for 125 kbps Data Rate	.54
7.5.10	Bluetooth Receiver Characteristics for 500 kbps Data Rate	.54
7.6	Typical Current Consumption	.55
7.6.1	WLAN 2.4 GHz 3.3 V Current Consumption	.56
7.6.2	Bluetooth LE Current Consumption	.57
<b>8.</b>	<b>Reference Schematics, BOM and Layout Guidelines</b>	<b>58</b>
8.1	Schematics	.58
8.1.1	System Supplies	.58
8.1.2	RF Supplies	.59
8.1.3	GPIO Supplies	.60
8.1.4	RF Frontend	.61
8.1.5	LF Clock Options	.62
8.1.6	Flash Memory Configurations	.63
8.1.7	Reset	.63
8.1.8	Host Interface	.64
8.2	BOM	.65
8.3	Layout Guidelines for DR-QFN	.68
8.4	Calibration Requirements	.69
<b>9.</b>	<b>Package Specifications</b>	<b>70</b>
9.1	Package Outline	.70
9.2	PCB Land Pattern	.73
9.3	Top Marking	.75
<b>10.</b>	<b>SiWN917 Documentation and Support</b>	<b>76</b>



### 3. Applications

#### Smart Home

Smart Locks, Motion/Entrance Sensors, Water Leak sensors, Smart plugs/switches, Light Emitting Diode (LED) lights, Door-bell cameras, Washers/Dryers, Refrigerators, Thermostats, Consumer Security cameras, Voice Assistants, etc.

#### Other Consumer Applications

Toys, Anti-theft tags, Smart dispensers, Weighing scales, Fitness Monitors, Blood pressure monitors, Blood sugar monitors, Portable cameras, etc.

#### Other Applications (Medical, Industrial, Retail, Agricultural, Smart City, etc.)

Healthcare Tags, Industrial Wearables, Infusion pumps, Sensors/actuators in Manufacturing, Electronic Shelf labels, Agricultural sensors, Product tracking tags, Smart Meters, Parking sensors, Street LED lighting, Automotive After-market, Security Cameras, Gateways, etc.

## 4. Block Diagrams

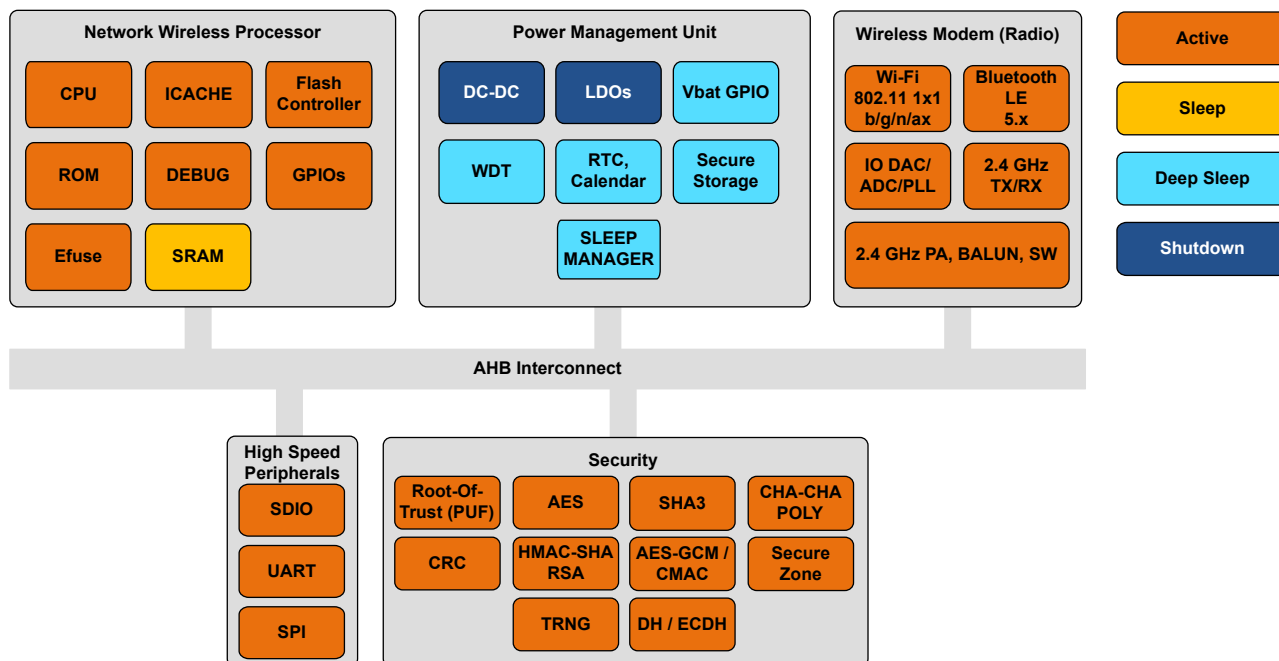

Figure 4.1. System Block Diagram

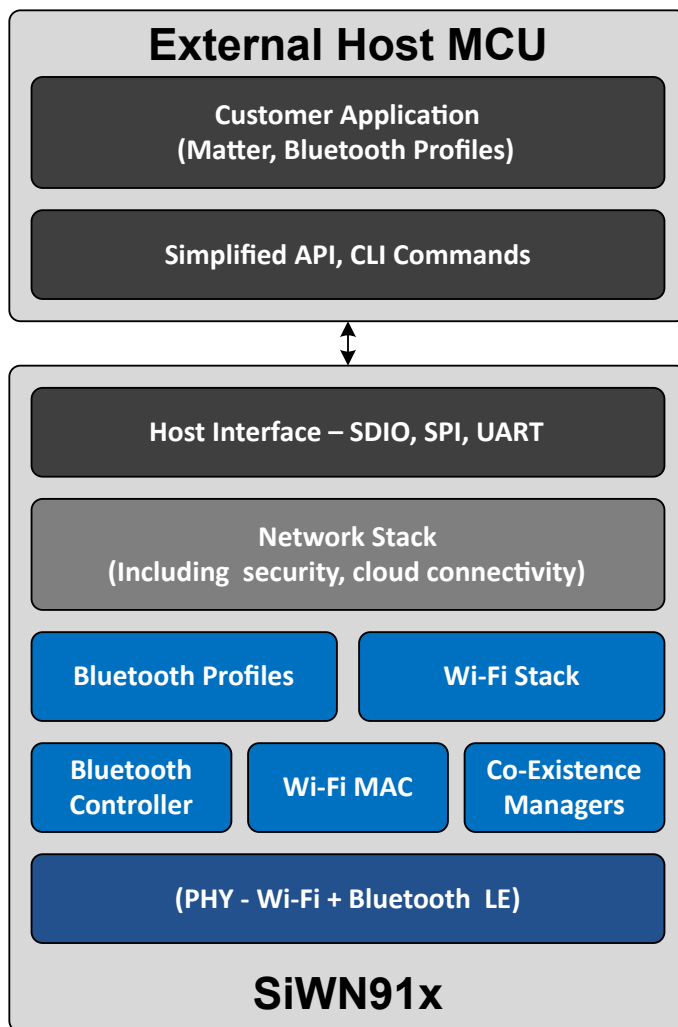

Figure 4.2. SiWN917 NCP Software Architecture

**Note:** Customer can connect multiple hosts, but only one host interface can be active after power-on.

## 5. System Overview

### 5.1 Introduction

SiWN91x NCP includes a Network Wireless Processor (NWP) 4-Threaded processor running up to 160 MHz. All the networking and wireless stacks run on independent threads of the NWP. In addition, the NWP subsystem also acts as the secure processing domain and takes care of secure boot, secure firmware update and provides access to security accelerators and secure peripherals through pre-defined APIs. The NWP-based "Networking, Security and Wireless subsystem" have power, clocks/PLLs, bus-matrices, and memory.

### 5.2 WLAN

- Compliant to single-spatial stream IEEE 802.11 b/g/n/ax with single band (2.4 GHz) support
- Support for 20 MHz channel bandwidth for 802.11n and 802.11ax.
- Operating Modes: Wi-Fi 4 STA, Wi-Fi 6 (802.11ax) STA, Wi-Fi 4 AP, Enterprise STA, Wi-Fi 6 STA + Wi-Fi 4 AP, Wi-Fi STA + BLE
- Wi-Fi 6 Features: Individual Target wake-up time (iTWT), Broadcast TWT (bTWT), SU extended range (ER), DCM (Dual Carrier Modulation), DL MU-MIMO, DL/UL OFDMA, MBSSID, BFRP, Spatial Reuse, BSS Coloring, and NDP feedback up to 4 antennas
- Integrated PA
- Data Rates—802.11b: up to 11 Mbps; 802.11g: up to 54 Mbps; 802.11n: MCS0 to MCS7; 802.11ax: MCS0 to MCS7
- Operating Frequency Range: 2412 MHz – 2484 MHz

#### 5.2.1 MAC

- Conforms to IEEE 802.11b/g/n/j/ax standards for MAC
- Hardware accelerators for AES
- WPA, WPA2, WPA3 and WMM support
- AMPDU aggregation for high performance
- Firmware downloaded from host based on application
- Hardware accelerators for DH (for WPS) and ECDH

#### 5.2.2 Baseband Processing

- Supports 11b: DSSS for 1, 2 Mbps and CCK for 5.5, 11 Mbps
- Supports all OFDM data rates
  - 802.11g: 6, 9, 12, 18, 24, 36, 48, 54 Mbps
  - 802.11ax, 802.11n: MCS 0 to MCS 7
- High-performance multipath handling in OFDM, DSSS, and CCK modes

### 5.3 Bluetooth

#### Key Features

- Transmit power up to +19 dBm with integrated PA
- Receive sensitivity — LE 1 Mbps: -96 dBm, LR 125 kbps: -107 dBm
- Operating Frequency Range — 2.402 GHz - 2.480 GHz
- Support LE (1 Mbps & 2 Mbps) and LR (125 kbps & 500 kbps) rates
- Advertising extensions
- Data length extensions
- LL privacy
- LE dual role
- BLE acceptlist
- Two simultaneous BLE connections (2 peripheral or 2 central, or 1 central and 1 peripheral)

### 5.3.1 MAC

#### Link Manager

- Creation, modification & release of physical links
- Connection establishment between Link managers of two Bluetooth devices
- Link supervision is implemented in Link Manager
- Link power control is done depending on the inputs from Link Controller
- Enabling & disabling of encryption & decryption on logical links
- AES hardware acceleration

#### Link Controller

- Encodes and decodes header of BLE packets
- Manages flow control, acknowledgment, re-transmission requests, etc.
- Stores the last packet status for all physical transports
- Indicates the success status of packet transmission to upper layers
- Indicates the link quality to the LMP layer

#### Device Manager

- Executes HCI Commands
- Controls Scan & Connection processes
- Controls all BLE Device operations except data transport operations
- BLE Controller state transition management
- Anchor point synchronization & management
- Scheduler

### 5.3.2 Baseband Processing

- Supports BLE 1 Mbps, 2 Mbps and long range 125 kbps, 500 kbps

### 5.4 RF Transceiver

- SiWN917 features two highly configurable RF transceivers supporting WLAN 11b/g/n/ax and Bluetooth LE wireless protocols. Both RF transceivers operate together in multiple modes covering High Performance (HP) and Low Power (LP) operations. List of operating modes are given in next section.
- It contains two fully integrated fractional-N frequency synthesizers having reference from internal oscillator with 40 MHz crystal. One of the synthesizer is a low power architecture which also caters single-bit data modulation feature for Bluetooth LE protocols.
- There are two transmitter chains in the chip. First one uses a direct conversion architecture getting carrier signal from the high-performance frequency synthesizer. It contains an on-chip balun and its output is terminated as single-ended output at "RF\_TX" pin. This transmitter supports all the mentioned WLAN protocols, and Bluetooth LE protocol for high output power. The second transmitter is a low power architecture for supporting constant envelope modulation formats. This has two outputs differentiated by their maximum output power level. The 0 dBm output is shared with "RF\_RX" pin and the 8 dBm output is terminated at "RF\_BLE\_TX" pin.
- The receiver contains two front end paths with a configurable common LNA catering HP and LP operations. This also has two analog base band blocks where one is zero-IF architecture supporting all the mentioned WLAN protocols and the other one is low-IF architecture supporting Bluetooth LE. Input to the pin is "RF\_RX" sharing with 0 dBm Tx output.
- Impedance matching for each RF pin needs to be done separately for optimum performance.

### 5.4.1 Receiver and Transmitter Operating Modes

The available radio operating modes are

- WLAN HP TX - WLAN High-Performance Transmitter with up to 19.5 dBm PA
- WLAN HP RX - WLAN High-Performance Receiver
- WLAN LP RX - WLAN Low-Power Receiver
- BLE HP TX - Bluetooth LE High-Performance Transmitter with up to 19 dBm PA
- BLE HP RX - Bluetooth LE High-Performance Receiver
- BLE LP TX - Bluetooth LE Low-Power Transmitter with 8 dBm PA
- BLE LP TX - Bluetooth LE Low-Power Transmitter with 0 dBm PA
- BLE LP RX - Bluetooth LE Low-Power Receiver

**Note:** All the TX / RX modes are automatically controlled by radio firmware and not individually selectable.

### 5.5 Host Interfaces

Three host interfaces are supported:

- SDIO
  - Version 2.0-compatible
  - Supports SD-SPI
  - 1-bit, and 4-bit SDIO modes
  - Operation up to a maximum clock speed of 50 MHz
- SPI
  - Operation up to a maximum clock speed of 100 MHz
- UART
  - Supports various baud rates up to 921600 bps. Note that Baud rates above 115200 bps require Hardware Flow control.

#### 5.5.1 Auto Host Detection

The SiWN917 detects the host interface automatically after connecting to respective host controllers like SDIO, SPI, UART. The SDIO / SPI host interface is detected through hardware packet exchanges. The UART host interface is detected through the software based on received packets on the UART interface. This Host configuration is stored in always-on domain registers after detection (on power up) and the information is reused at each wakeup.

### 5.6 Security Features

- Secure Boot
- Secure OTA Firmware update
- TRNG: Generates high-entropy random numbers based on RF noise, increasing the effort/time needed to expose secret keys
- Secure Zone
- Secure Key storage : HW device identity and key storage with PUF
- Debug Lock
- Anti Rollback : Firmware downgrade to a lower version is prohibited through OTP to prevent the use of older, potentially vulnerable FW version
- Encrypted XIP from flash with XTS/CTR mode
- Secure Attestation : Allows a device to authenticate its identity using a cryptographically signed token and exchange of secret keys
- Hardware Accelerators: AES128/256/192, SHA256/384/512, HMAC, RNG, CRC, SHA3, AES-GCM/ CMAC, ChaCha-poly
- Software Implementation: RSA and ECC

### 5.7 Embedded Wi-Fi Software

- The wireless software package supports Embedded Wi-Fi (802.11 b/g/n/ax) Client mode, Wi-Fi Access point mode (up to 4 clients), and Enterprise Security in client mode.
- The software package includes complete firmware and application profiles.
- It has a wireless coexistence manager to arbitrate between protocols.

## 5.7.1 Security

Wireless software supports multiple levels of security capabilities available for the development of IoT devices.

- Accelerators: AES128/256
- WPA/WPA2/WPA3-Personal, WPA/WPA2/WPA3 Enterprise for Client

## 5.8 Power Architecture

The Power Control Hardware implements the control sequences for transitioning between different power states (Active/Standby/Sleep/Shutdown).

### 5.8.1 Highlights

- Two integrated buck switching regulators (High performance and ULP) to enable efficient Voltage Scaling across wide operating mode currents ranging from <math><1\ \mu\text{A}</math> to 170 mA
- Multiple voltage domains with Independent voltage scaling of each domain.
- Fine grained power-gating including peripherals, buses and pads, thereby reducing power consumption when the peripheral/buses/pads are inactive.
- Flexible switching between different Active states with controls from Software.
- Hardware based wakeup from Standby/Sleep/Shutdown states.
- All the peripherals are clock gated by default thereby reducing the power consumption in inactive state.
- Low wakeup times as configurable by Software.

### 5.8.2 System Power Supply Configurations

SiWN917 chipsets support highly flexible power supply configurations for various application scenarios. Two application scenarios are listed below.

- 3.3 V single supply - A single 3.3 V supply derived from the system PMU can be input to all I/O supplies.
- 1.8 V and 3.3 V supply - A 1.8 V supply derived from the system PMU can be input to all I/O supplies except PA2G\_AVDD. A 3.3 V supply derived from system Power Management Unit (PMU) can be fed to the power amplifier supply pin PA2G\_AVDD. There will be slight RF performance degradation if antenna select signals (ULP\_GPIO\_4, ULP\_GPIO\_5, ULP\_GPIO\_0) are powered at 1.8 V from the ULP\_IO\_VDD supply.

### 5.8.3 Power Management

The SiWN917 chipsets have an internal power management subsystem, including DC-DC converters and linear regulators. This subsystem generates all the voltages required by the chipset to operate from a wide variety of input sources.

- LC DC-DC switching converter for RF and digital blocks
  - Input voltage (1.8 V or 3.3 V) on pin VINBCKDC
  - Nominal Output - 1.45 V and 170 mA maximum load on pin VOUTBCKDC
- SC DC-DC - Switching converter for Always-ON core logic domain
  - Input voltage (1.8 V or 3.3 V) on pin UULP\_VBATT\_1 and UULP\_VBATT\_2
  - Nominal Outputs
    - 1.05 V on pin UULP\_VOUTSCDC
    - 0.75 V on pin UULP\_VOUTSCDC\_RETN
- SoC LDO - Linear regulator for digital blocks
  - Input - 1.45 V from LC DC-DC or external regulated supply on pin VINLDOSOC
  - Nominal Output - 1.15 V and 100 mA maximum load on pin VOUTLDOSOC
- LDO RF and AFE - Linear regulator for RF and AFE
  - Input - 1.45 V from LC DC-DC or external regulated supply on pin RF\_AVDD
  - Nominal Output - 1.21 V on pin VOUTLDOAFE

**Note:** Output of VOUTLDOAFE will be 0.75 V - 1.05 V after initial power-up, until the RF has been initialized.

- Flash LDO - Linear regulator for In-package flash and external memories
  - Input voltage (1.8 V or 3.3 V) on pin VINLDO1P8
  - Nominal Output - 1.8 V and 48 mA maximum load on pin VOUTLDO1P8

## 5.9 Memory Architecture

There are on chip Read Only Memory(ROM), Random Access Memory(RAM) and in-package flash connectivity. Sizes of ROM/RAM/flash will vary depending on the chip configuration.

The NWP processor has the following memory:

- Embedded SRAM up to 672 KB total
- 448 KB of ROM which holds the Secure primary bootloader, Network Stack, Wireless stacks and security functions
- 16 KB of Instruction cache (I cache)
- Flash up to 4 MB (in-package)
- eFuse of 1024 bytes (used to store primary boot configuration, security and calibration parameters)

## 5.10 Low Power Modes

It supports Ultra-low power consumption with multiple power modes to reduce system energy consumption.

- Voltage and Frequency Scaling
- Deep sleep (ULP) mode with only the sleep timer active – with and without RAM retention
- Wi-Fi standby associated mode with automatic periodic wake-up
- Automatic clock gating of the unused blocks or transit the system from Normal to ULP mode.

### 5.10.1 ULP Mode

In Ultra Low Power mode, the deep sleep manager has control over the processors and subsystems and controls their active and sleep states. During deep sleep, the always-on logic domain operates on a lowered supply and a low-frequency clock to reduce power consumption. The ULP mode supports the following wake-up options:

- Timeout wakeup - Exit sleep state after programmed timeout value.
- GPIO Based Wakeup: Exit sleep state when GPIO goes High/Low based on programmed polarity.



## 6.2 Pin Description

### 6.2.1 RF and Control Interfaces

**Table 6.1. Chip Packages - RF and Control Interfaces**

Pin Name	Pin Number	I/O Supply Domain	Direction	Initial State (Power up, Active Reset)	Description
RF_TX	A9	PA2G_AVDD	Output	NA	2.4 GHz High Performance RF Output.
RF_RX	A10	RF_AVDD	Inout	NA	2.4 GHz RF Input for both High Performance and Low Power WLAN and BLE. It can also be used as 2.4 GHz RF output for BLE Low Power 0 dBm RF chain.
RF_BLE_TX	A11	RF_AVDD	Output	NA	2.4 GHz RF Output for Low Power BLE 8 dBm.
RESET_N	A31	UULP_VBATT_2	Inout	NA	Active-low asynchronous reset signal, which resets only digital blocks. RESET_N will be pulled low if POC_IN is low.
POC_IN	A27	UULP_VBATT_1	Input	NA	This is an input to the chip which resets all analog and digital blocks in the device. It should be made high only after supplies are valid to ensure the IC is in safe state until valid power supply is available.
POC_OUT	B25	UULP_VBATT_1	Output	NA	This is internally generated. Initially, it is low. But it becomes high when the supplies (UULP_VBATT_1, UULP_VOUTSCDC) are valid.
ULP_GPIO_0	A35	ULP_IO_VDD	Inout	NA	Antenna select pin for External switch configuration. Please refer to Reference schematics for more info. For internal RF switch configuration, may be used for GPIO functions.
ULP_GPIO_4	B21	ULP_IO_VDD	Inout	NA	Antenna select pin for External switch configuration. Please refer to Reference schematics for more info. For internal RF switch configuration, may be used for GPIO functions.
ULP_GPIO_5	A19	ULP_IO_VDD	Inout	NA	Antenna select pin for External switch configuration. Please refer to Reference schematics for more info. For internal RF switch configuration, may be used for GPIO functions.

## 6.2.2 Power and Ground Pins

**Table 6.2. Chip Packages - Power and Ground Pins**

Pin Name	Type	Pin Number	Direction	Description
UULP_VBATT_1	Power	A26	Input	Always-on VBATT Power supply to the UULP domains.
UULP_VBATT_2	Power	A30	Input	Always-on VBATT Power supply to the UULP domains.
RF_VBATT	Power	A12	Input	Always-on VBATT Power supply to the RF.
VINBCKDC	Power	A33	Input	Power supply for the on-chip buck DC-DC.
VOUTBCKDC	Power	B29	Output	Output of the on-chip buck DC-DC.
VINLDOSOC	Power	B30	Input	Power supply for SoC LDO. Connect to VOUTBCKDC as per the Reference Schematics.
VOUTLDOSOC	Power	A34	Output	Output of SoC LDO.
VINLDO1P8	Power	B31	Input	Power supply for 1.8 V LDO
VOUTLDO1P8	Power	B32	Output	Output of 1.8 V LDO.
VOUTLDOAFE	Power	B13	Output	Output of RF AFE LDO.
FLASH_IO_VDD	Power	A2	Input	I/O Supply for In-Package Flash/PSRAM. Connect to VOUTLDO1P8 as per the Reference Schematics.
IO_VDD_1	Power	A3	Input	I/O Supply for GPIOs. Refer to the GPIOs section for details on which GPIOs have this as the I/O supply.
IO_VDD_2	Power	B14	Input	I/O Supply for GPIOs. Refer to the GPIOs section for details on which GPIOs have this as the I/O supply.
IO_VDD_3 (SDIO_IO_VDD)	Power	B1	Input	I/O Supply for SDIO I/Os. Refer to the GPIOs section for details on which GPIOs have this as the I/O supply.
ULP_IO_VDD	Power	B33	Input	I/O Supply for ULP GPIOs.
PA2G_AVDD	Power	B8	Input	Power supply for the 2.4 GHz RF Power Amplifier.
RF_AVDD	Power	A8, A14, B11	Input	Power supply for the 2.4 GHz RF and AFE. Connect to VOUTBCKDC as per the Reference Schematics.
AUX_AVDD	Power	B34	Output	Auxiliary LDO Output supply for the Analog peripherals.
UULP_VOUTSCDC	Power	B23	Output	UULP Switched Cap DCDC Output.
UULP_VOUTSCDC_RETN	Power	A28	Output	UULP Retention Supply Output.
C_VDD	Power	B2, A18, B38	Input	Power supply for the digital core. Connect to the VOUTLDOSOC as per the Reference Schematics.
GND	Ground	GND Paddle	GND	Common ground pins.

### 6.2.3 Peripheral Interfaces

Table 6.3. Chip Packages - Peripheral Interfaces

Pin Name	Pin Number	I/O Supply Domain	Direction	Initial State (Power up, Active Reset)	Description <sup>1,2,3,4,5,6,7</sup>									
GPIO_6	B20	IO_VDD_1	Inout	HighZ	<b>Default:</b> HighZ <b>Sleep:</b> HighZ									
GPIO_7	B19	IO_VDD_1	Inout	HighZ	<b>Default:</b> HighZ <b>Sleep:</b> HighZ  This pin can be configured by software to be any of the following.  PTA_GRANT: "PTA Grant" output signal is part of 3-wire coexistence (Packet Traffic Arbitration) interface.									
GPIO_8/UART1_RX	A20	IO_VDD_1	Inout	HighZ	<table border="1"> <thead> <tr> <th>Host</th> <th>Default</th> <th>Sleep</th> </tr> </thead> <tbody> <tr> <td>UART</td> <td>UART1_RX - UART Host interface serial input.</td> <td>HighZ</td> </tr> <tr> <td>Non UART</td> <td>HighZ</td> <td>HighZ</td> </tr> </tbody> </table>	Host	Default	Sleep	UART	UART1_RX - UART Host interface serial input.	HighZ	Non UART	HighZ	HighZ
Host	Default	Sleep												
UART	UART1_RX - UART Host interface serial input.	HighZ												
Non UART	HighZ	HighZ												
GPIO_9/UART1_TX	A21	IO_VDD_1	Inout	HighZ	<table border="1"> <thead> <tr> <th>Host</th> <th>Default</th> <th>Sleep</th> </tr> </thead> <tbody> <tr> <td>UART</td> <td>UART1_TX - UART Host interface serial output.</td> <td>HighZ</td> </tr> <tr> <td>Non UART</td> <td>HighZ</td> <td>HighZ</td> </tr> </tbody> </table>	Host	Default	Sleep	UART	UART1_TX - UART Host interface serial output.	HighZ	Non UART	HighZ	HighZ
Host	Default	Sleep												
UART	UART1_TX - UART Host interface serial output.	HighZ												
Non UART	HighZ	HighZ												
GPIO_10	B3	IO_VDD_1	Inout	HighZ	<b>Default:</b> HighZ <b>Sleep:</b> HighZ  This pin can be configured by software to be any of the following. <ul style="list-style-type: none"> <li>• HOST_WAKEUP_IND: This is used as indication from host to dev that host is ready to take the packet and device can transfer the packet to host. This is supported only in UART host mode.</li> <li>• It is part of Wake-on-Wireless functionality. Please check with Silabs for availability of this functionality</li> </ul>									

Pin Name	Pin Number	I/O Supply Domain	Direction	Initial State (Power up, Active Reset)	Description <sup>1,2,3,4,5,6,7</sup>												
GPIO_11	B4	IO_VDD_1	Inout	HighZ	<p><b>Default:</b> HighZ</p> <p><b>Sleep:</b> HighZ</p> <p>This pin can be configured by software to be any of the following.</p> <ul style="list-style-type: none"> <li>• WAKEUP_FROM_DEV: Used as a wakeup indication to host from device.</li> <li>• It is part of Wake-on-Wireless functionality. It is recommended that one use an external weak pull-down resistor on this pin and software has to be configured suitably.</li> <li>• Please check with Silabs for availability of this functionality.</li> </ul>												
GPIO_12	A4	IO_VDD_1	Inout	HighZ	<p><b>Default:</b> HighZ</p> <p><b>Sleep:</b> HighZ</p> <p>This pin can be configured by software to be any of the following.</p> <ul style="list-style-type: none"> <li>• UART1_RTS - UART interface Request to Send, if UART Host Interface flow control is enabled.</li> </ul>												
GPIO_15	A41	IO_VDD_3	Inout	HighZ	<p><b>Default:</b> HighZ</p> <p><b>Sleep:</b> HighZ</p> <p>This pin can be configured by software to be any of the following.</p> <ul style="list-style-type: none"> <li>• UART1_CTS - UART interface Clear to Send, if UART Host Interface flow control is enabled.</li> </ul>												
GPIO_25/SDIO_CLK/ HSPI_CLK	B40	IO_VDD_3	Inout	HighZ	<table border="1"> <thead> <tr> <th>Host</th> <th>Default</th> <th>Sleep</th> </tr> </thead> <tbody> <tr> <td>SDIO</td> <td>SDIO_CLK - SDIO interface clock</td> <td>HighZ</td> </tr> <tr> <td>SPI</td> <td>HSPI_CLK - SPI Slave interface clock</td> <td>HighZ</td> </tr> <tr> <td>Non SDIO,SPI</td> <td>HighZ</td> <td>HighZ</td> </tr> </tbody> </table>	Host	Default	Sleep	SDIO	SDIO_CLK - SDIO interface clock	HighZ	SPI	HSPI_CLK - SPI Slave interface clock	HighZ	Non SDIO,SPI	HighZ	HighZ
Host	Default	Sleep															
SDIO	SDIO_CLK - SDIO interface clock	HighZ															
SPI	HSPI_CLK - SPI Slave interface clock	HighZ															
Non SDIO,SPI	HighZ	HighZ															

Pin Name	Pin Number	I/O Supply Domain	Direction	Initial State (Power up, Active Reset)	Description 1,2,3,4,5,6,7		
GPIO_26/SDIO_CMD/ HSPI_CSN	A1	IO_VDD_3	Inout	HighZ	Host	Default	Sleep
					SDIO	SDIO_CMD - SDIO interface CMD signal	HighZ
					SPI	HSPI_CSN - Active-low Chip Select signal of SPI Slave interface	HighZ
					Non SDIO,SPI	HighZ	HighZ
GPIO_27/SDIO_D0/ HSPI_MOSI	B39	IO_VDD_3	Inout	HighZ	Host	Default	Sleep
					SDIO	SDIO_D0 - SDIO interface Data0 signal	HighZ
					SPI	HSPI_MOSI - SPI Slave interface Master-Out-Slave-In signal	HighZ
					Non SDIO,SPI	HighZ	HighZ
GPIO_28/SDIO_D1/ HSPI_MISO	A44	IO_VDD_3	Inout	HighZ	Host	Default	Sleep
					SDIO	SDIO_D1 - SDIO interface Data1 signal	HighZ
					SPI	HSPI_MISO - SPI Slave interface Master-In-Slave-Out signal	HighZ
					Non SDIO,SPI	HighZ	HighZ

Pin Name	Pin Number	I/O Supply Domain	Direction	Initial State (Power up, Active Reset)	Description <sup>1,2,3,4,5,6,7</sup>		
GPIO_29/SDIO_D2/ HSPI_INTR	A43	IO_VDD_3	Inout	HighZ	Host	Default	Sleep
					SDIO	SDIO_D2 - SDIO interface Data2 signal	HighZ
					SPI	HSPI_INTR - SPI Slave interface Interrupt Signal to the Host	HighZ
					Non SDIO,SPI	HighZ	HighZ
GPIO_30/SDIO_D3	A42	IO_VDD_3	Inout	Pullup	Host	Default	Sleep
					SDIO	SDIO_D3 - SDIO interface Data3 signal	HighZ
					Non SDIO,SPI	High	HighZ
					<b>Default:</b> HighZ		
GPIO_46	A5	IO_VDD_1	Inout	HighZ	<b>Sleep:</b> HighZ		
GPIO_47	A7	IO_VDD_1	Inout	HighZ	<b>Default:</b> HighZ		
GPIO_48	B7	IO_VDD_1	Inout	HighZ	<b>Sleep:</b> HighZ		
GPIO_49	B6	IO_VDD_1	Inout	HighZ	<b>Default:</b> HighZ		
GPIO_50	A6	IO_VDD_1	Inout	HighZ	<b>Sleep:</b> HighZ		
GPIO_51	B5	IO_VDD_1	Inout	HighZ	<b>Default:</b> HighZ		
GPIO_52	A38	IO_VDD_1	Inout	HighZ	<b>Sleep:</b> HighZ		
GPIO_53	B35	IO_VDD_1	Inout	HighZ	<b>Default:</b> HighZ		
GPIO_54	A39	IO_VDD_1	Inout	HighZ	<b>Sleep:</b> HighZ		
GPIO_55	B36	IO_VDD_1	Inout	HighZ	<b>Default:</b> HighZ		
					<b>Sleep:</b> HighZ		

Pin Name	Pin Number	I/O Supply Domain	Direction	Initial State (Power up, Active Reset)	Description <sup>1,2,3,4,5,6,7</sup>
GPIO_56	A40	IO_VDD_1	Inout	HighZ	<b>Default:</b> HighZ <b>Sleep:</b> HighZ
GPIO_57	B37	IO_VDD_1	Inout	HighZ	<b>Default:</b> HighZ <b>Sleep:</b> HighZ
ULP_GPIO_0	A35	ULP_IO_VDD	Inout	HighZ	<b>Default:</b> HighZ <b>Sleep:</b> HighZ  Antenna select pin for external switch configuration. Please refer to reference schematics for more info. For internal RF switch configuration, may be used for GPIO functions.
ULP_GPIO_1	B22	ULP_IO_VDD	Inout	HighZ	<b>Default:</b> HighZ <b>Sleep:</b> HighZ  This pin can be configured by software to be any of the following <ul style="list-style-type: none"> <li>PTA_REQ: "PTA Request" input signal is part of 3-wire coexistence (Packet Traffic Arbitration) interface.</li> </ul>
ULP_GPIO_2	A37	ULP_IO_VDD	Inout	HighZ	<b>Default:</b> HighZ <b>Sleep:</b> HighZ
ULP_GPIO_4	B21	ULP_IO_VDD	Inout	HighZ	<b>Default:</b> HighZ <b>Sleep:</b> HighZ  Antenna select pin for external switch configuration. Please refer to reference schematics for more info. For internal RF switch configuration, may be used for GPIO functions.
ULP_GPIO_5	A19	ULP_IO_VDD	Inout	HighZ	<b>Default:</b> HighZ <b>Sleep:</b> HighZ  Antenna select pin for external switch configuration. Please refer to reference schematics for more info. For internal RF switch configuration, may be used for GPIO functions.
ULP_GPIO_6	A22	ULP_IO_VDD	Inout	HighZ	<b>Default:</b> HighZ <b>Sleep:</b> HighZ  This pin can be configured by software to be any of the following. <ul style="list-style-type: none"> <li>PTA_PRIO: "PTA Priority" input signal is part of 3-wire coexistence (Packet Traffic Arbitration) interface.</li> </ul>

Pin Name	Pin Number	I/O Supply Domain	Direction	Initial State (Power up, Active Reset)	Description <sup>1,2,3,4,5,6,7</sup>
ULP_GPIO_7	B18	ULP_IO_VDD	Inout	HighZ	<b>Default:</b> HighZ <b>Sleep:</b> HighZ
ULP_GPIO_8	A36	ULP_IO_VDD	Inout	HighZ	<b>Default:</b> HighZ <b>Sleep:</b> HighZ
ULP_GPIO_9 / UART2_TX	A24	ULP_IO_VDD	Inout	HighZ	<b>Default:</b> UART2_TX- Debug UART Interface serial output <b>Sleep:</b> HighZ
ULP_GPIO_10	A23	ULP_IO_VDD	Inout	HighZ	<b>Default:</b> HighZ <b>Sleep:</b> HighZ
ULP_GPIO_11	B17	ULP_IO_VDD	Inout	HighZ	<b>Default:</b> HighZ <b>Sleep:</b> HighZ
UULP_VBAT_GPIO_0	B10	UULP_VBATT_1	Output	High	<b>Default:</b> High <b>Sleep:</b> High  This pin can be configured by software to be any of the following. <ul style="list-style-type: none"> <li><b>SLEEP_IND_FROM_DEV:</b> This signal is used to send an indication to the Host processor. An indication is sent when the chip enters (logic low) and exits (logic high) the ULP Sleep mode.</li> </ul>
UULP_VBAT_GPIO_1	B27	UULP_VBATT_1	Inout	HighZ	<b>Default:</b> HighZ <b>Sleep:</b> HighZ  UULP_VBAT_GPIO_1: Reserved
UULP_VBAT_GPIO_2	B24	UULP_VBATT_1	Inout	HighZ	<b>Default:</b> HighZ <b>Sleep:</b> ULP_WAKEUP  This pin can be configured by software to be any of the following. <ul style="list-style-type: none"> <li><b>HOST_BYP_ULP_WAKEUP:</b> This signal has two functionalities – one during the bootloading process and one after the bootloading. During bootloading, this signal is an active-high input to indicate that the bootloader should bypass any inputs from the Host processor and continue to load the default firmware from Flash. After bootloading, this signal is an active-high input to indicate that the device should wakeup from its Ultra Low Power (ULP) sleep mode.</li> </ul>

Pin Name	Pin Number	I/O Supply Domain	Direction	Initial State (Power up, Active Reset)	Description <sup>1,2,3,4,5,6,7</sup>
UULP_VBAT_GPIO_3	A25	UULP_VBATT_1	Inout	HighZ	<b>Default:</b> HighZ <b>Sleep:</b> HighZ Reserved
JP0	A17	IO_VDD_2	Input	Pullup	<b>Default:</b> JP0 <b>Sleep:</b> HighZ JP0 - Reserved. Connect to a test point for debugging purposes
JP1	B16	IO_VDD_2	Input	Pullup	<b>Default:</b> JP1 <b>Sleep:</b> HighZ JP1 - Reserved. Connect to a test point for debugging purposes
JP2	A16	IO_VDD_2	Input	Pullup	<b>Default:</b> JP2 <b>Sleep:</b> HighZ JP2 - Reserved. Connect to a test point for debugging purposes
JNC	B15	IO_VDD_2	Output	Pullup	<b>Default:</b> JNC <b>Sleep:</b> HighZ JNC - Reserved. Connect to a test point for debugging purposes

**Note:**

1. "Default" state refers to the state of the device after initial boot loading and firmware loading is complete.
2. "Sleep" state refers to the state of the device after entering Sleep state.
3. Please refer to "Hardware Reference Manual" for software programming information.
4. Please refer to "Software Reference Manual" for software programming information.
5. In the application, wherever SiWN917 is connected to an external host, during the power-off state, the host should ensure that all the pins (analog or digital) connected to the SiWN917 are not driven. Else, the pins must be grounded.
6. Connect each of these pins to test point for debugging purposes - JP0, JP1, JP2, JNC.
7. GPIOs without a described Pin function cannot be configured in software, and cannot be used as standard GPIOs.

**6.2.4 Miscellaneous Pins**

**Table 6.4. Miscellaneous Pins**

Pin Name	Pin Number	I/O Supply Domain	Direction	Initial State (Power up, Active Reset)	Description
FLY_P1	B28	NA	Input	NA	Fly Capacitor for Switched cap DCDC. Please refer to Reference Schematics
FLY_N1	A32	NA	Input	NA	Fly Capacitor for Switched cap DCDC. Please refer to Reference Schematics

Pin Name	Pin Number	I/O Supply Do- main	Direction	Initial State (Power up, Ac- tive Reset)	Description
XTAL_IN	B12	RF_VBATT	Input	NA	Input to the on-chip oscillator from the external 40 MHz crystal.
XTAL_OUT	A13	RF_VBATT	Output	NA	Output of the on-chip oscillator to the external 40 MHz crystal.
TRST	A15	IO_VDD_2	Input	HighZ	Test signal. Connect to Ground.
XTAL_32KHZ_N	B26	NA	Inout	NA	Analog Pin. 32.768 kHz crystal connection
XTAL_32KHZ_P	A29	NA	Inout	NA	Analog Pin. 32.768 kHz crystal connection
NC	B9	NA	NA	NA	No-Connect

## 7. Electrical Specifications

### 7.1 Absolute Maximum Ratings

Stresses beyond those listed below may cause permanent damage to the device. This is a stress rating only and functional operation of the devices at those or any other conditions beyond those indicated in the operation listings of this specification is not implied. Exposure to maximum rating conditions for extended periods may affect device reliability. For more information on the available quality and reliability data, see the Quality and Reliability Monitor Report at <https://www.silabs.com/about-us/quality>.

**Table 7.1. Absolute Maximum Ratings**

Parameter	Symbol	Test Condition	Min	Typ	Max	Unit
Storage temperature	$T_{store}$		-40	—	125	°C
Maximum junction temperature	$T_{j\_max}$		—	—	125	°C
Always-on VBATT supply to the UULP Domains	$V_{UULP\_VBATT\_1}$		-0.5	—	3.63	V
Always-on VBATT supply to the UULP Domains	$V_{UULP\_VBATT\_2}$		-0.5	—	3.63	V
Always-on VBATT Power supply to the RF	$V_{RF\_VBATT}$		-0.5	—	3.63	V
Power supply for the on-chip Buck	$V_{VINBCKDC}$		-0.5	—	3.63	V
Power supply for SoC LDO	$V_{VINLDOSOC}$		-0.5	—	1.8	V
Power supply for 1.8 V LDO	$V_{VINLDO1P8}$		-0.5	—	3.63	V
I/O supply for In-Package Flash/PSRAM	$V_{FLASH\_IO\_VDD}$		-0.5	—	3.63	V
I/O supplies for GPIOs	$V_{IO\_VDD\_1}$		-0.5	—	3.63	V
I/O supplies for GPIOs	$V_{IO\_VDD\_2}$		-0.5	—	3.63	V
I/O supplies for GPIOs	$V_{IO\_VDD\_3}$		-0.5	—	3.63	V
I/O supplies for ULP GPIOs	$V_{ULP\_IO\_VDD}$		-0.5	—	3.63	V
DC voltage on any I/O pin <sup>1</sup>	$V_{IO\_PIN}$		-0.5	—	VDD + 0.5	V
Current per I/O pin	$I_{IOMAX}$	Sink	—	—	100	mA
		Source	—	—	100	mA
Power supply for the 2.4 GHz RF Power Amplifier	$V_{PA2G\_AVDD}$		-0.5	—	3.63	V
Power supply for the 2.4 GHz RF and AFE	$V_{RF\_AVDD}$		-0.5	—	1.98	V
Power supply for the digital core	$V_{C\_VDD}$		-0.5	—	1.21	V
Total average max current into chip	$I_{Pmax}$		—	—	500	mA

**Note:**

1. VDD = I/O supply domain pin. Refer to pin description tables for supply domain associated with each I/O.

## 7.2 Recommended Operating Conditions

**Note:** The device may operate continuously at the maximum allowable ambient  $T_{\text{ambient}}$  rating as long as the maximum junction  $T_{\text{junction(max)}}$  is not exceeded. For an application with significant power dissipation, the allowable  $T_{\text{ambient}}$  may be lower than the maximum  $T_{\text{ambient}}$  rating.  $T_{\text{ambient}} = T_{\text{junction(max)}} - (\Theta_{\text{JA}} \times \text{Power Dissipation})$ . Refer to the Thermal Characteristics table for  $\Theta_{\text{JA}}$ .

**Table 7.2. Recommended Operating Conditions**

Parameter	Symbol	Test Condition	Min	Typ	Max	Unit
Ambient temperature	$T_{\text{ambient}}$		-40	25	85	°C
Junction temperature	$T_{\text{junction}}$		—	—	105	°C
Power supply for UULP_VBATT_1, UULP_VBATT_2, and RF_VBATT <sup>1</sup>	$V_{\text{VBATT}}$	3.3 V nominal operation	2.97	3.3	3.63	V
		1.8 V nominal operation	1.71	1.8	1.98	V
Power supply for the on-chip Buck <sup>1</sup>	$V_{\text{VINBCKDC}}$	3.3 V nominal operation	2.97	3.3	3.63	V
		1.8 V nominal operation	1.71	1.8	1.98	V
Power supply for 1.8 V LDO <sup>1</sup>	$V_{\text{VINLDO1P8}}$	Regulation mode	2.97	3.3	3.63	V
		Bypass mode	1.71	1.8	1.98	V
Power supply for SoC LDO	$V_{\text{VINLDO SOC}}$		1.35	1.45	1.55	V
I/O supply for In-Package Flash/PSRAM	$V_{\text{FLASH\_IO\_VDD}}$		1.71	1.8	1.98	V
Power supply for the 2.4 GHz RF Power Amplifier	$V_{\text{PA2G\_AVDD}}$		2.97	3.3	3.63	V
Power supply for IO_VDD_1 <sup>1</sup>	$V_{\text{IO\_VDD\_1}}$	3.3 V nominal operation	2.97	3.3	3.63	V
		1.8 V nominal operation	1.71	1.8	1.98	V
Power supply for IO_VDD_2 <sup>1</sup>	$V_{\text{IO\_VDD\_2}}$	3.3 V nominal operation	2.97	3.3	3.63	V
		1.8 V nominal operation	1.71	1.8	1.98	V
Power supply for IO_VDD_3 <sup>1</sup>	$V_{\text{IO\_VDD\_3}}$	3.3 V nominal operation	2.97	3.3	3.63	V
		1.8 V nominal operation	1.71	1.8	1.98	V
Power supply for ULP_IO_VDD <sup>1</sup>	$V_{\text{ULP\_IO\_VDD}}$	3.3 V nominal operation	2.97	3.3	3.63	V
		1.8 V nominal operation	1.71	1.8	1.98	V

**Note:**

1. Supplies can operate at a nominal 3.3 V or 1.8 V level independent of the other supplies in the system.

## 7.3 DC Characteristics

### 7.3.1 RESET\_N and POC\_IN Pins

Table 7.3. RESET\_N and POC\_IN Pins

Parameter	Symbol	Test Condition	Min	Typ	Max	Unit
High level input voltage	V <sub>IH</sub>	RESET_N pin, UULP_VBATT_2 = 3.3 V	0.8 * UULP_VBATT_2	—	—	V
		RESET_N pin, UULP_VBATT_2 = 1.8 V	1.17	—	—	V
		POC_IN pin, UULP_VBATT_1 = 3.3 V	2.76	—	—	V
		POC_IN pin, UULP_VBATT_1 = 1.8 V	1.38	—	—	V
Low level input voltage	V <sub>IL</sub>	RESET_N pin, UULP_VBATT_2 = 3.3 V	—	—	0.3 * UULP_VBATT_2	V
		RESET_N pin, UULP_VBATT_2 = 1.8 V	—	—	0.63	V
		POC_IN pin, UULP_VBATT_1 = 3.3 V	—	—	1.10	V
		POC_IN pin, UULP_VBATT_1 = 1.8 V	—	—	0.24	V

### 7.3.2 Power On Control (POC) and Reset

There are three signals involved in power-on control and reset of the device:

- POC\_IN: When pulled low, POC\_IN will reset all of the internal blocks in the device. The POC\_IN signal can be controlled either by external circuitry, by POC\_OUT, or both.
- RESET\_N: RESET\_N is an open-drain signal which will be pulled low during a chip reset. It is released after POC\_IN is high. RESET\_N should be connected to an RC circuit to fulfill the timing requirements shown in [Figure 7.1. Power Up Sequence](#).
- POC\_OUT: The POC\_OUT signal is the output of the internal blackout supply monitor. POC\_OUT is distributed to all I/O cells to prevent the I/O cells from powering up in an undesired configuration and is also used inside the IC to place the IC in a safe state until a valid supply is available for proper operation. During power up, POC\_OUT stays low until the UULP\_VBATT\_1 reaches 1.6 V. After the VBATT supply exceeds 1.6 V, POC\_OUT becomes high and normal operation begins. If VBATT becomes lower than the blackout threshold voltage, POC\_OUT will return low. POC\_OUT can be used to provide chip reset by connecting to POC\_IN in a loopback configuration.

The recommended schematic for the reset signals is shown in [8.1 Schematics](#).

[Figure 7.1. Power Up Sequence](#) shows the signal timing when POC\_OUT, POC\_IN, and RESET\_N are connected per the recommended schematic. The POC\_IN-to-RESET\_N delay will occur when POC\_IN transitions from low to high. VBATT in the figure refers to the connection of UULP\_VBATT\_1 and UULP\_VBATT\_2 (connected together in the schematic).

In this configuration the system only has to control the supply (VBATT) during power-up and power down and need not control POC\_IN externally. On power-up the chip will be reset internally. The power-down sequence will follow VBATT and external control of POC\_IN is not required.

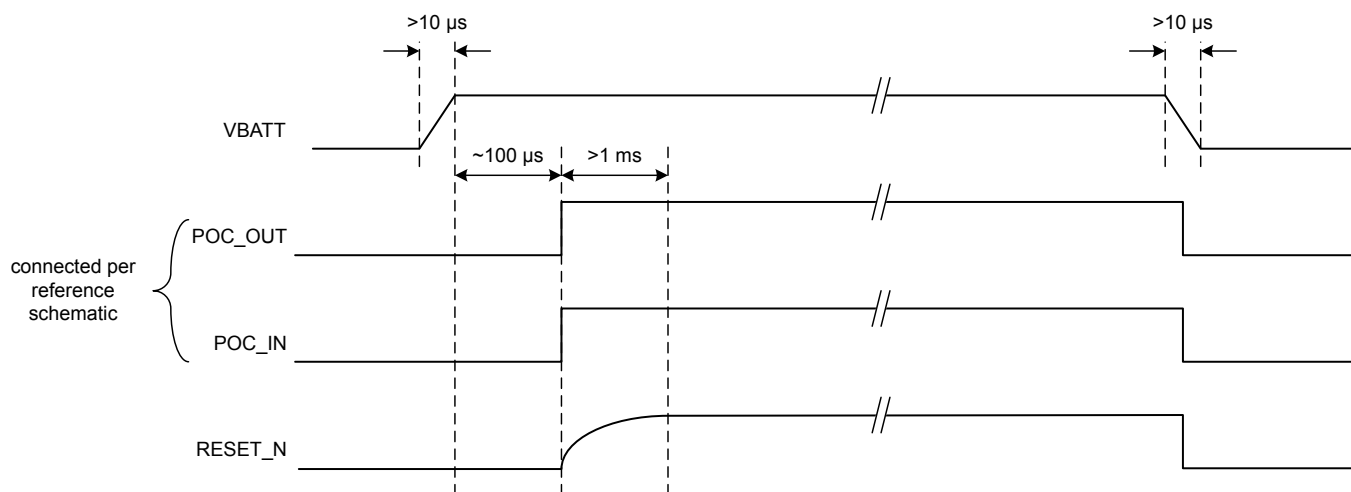

**Figure 7.1. Power Up Sequence**

If the chip is to be reset from an external host device while powered up, the POC\_IN signal should be pulled low for at least 10 ms as shown in [Figure 7.2. External Reset via POC\\_IN](#). Upon release of POC\_IN, the POC\_IN-to-RESET\_N delay will occur.

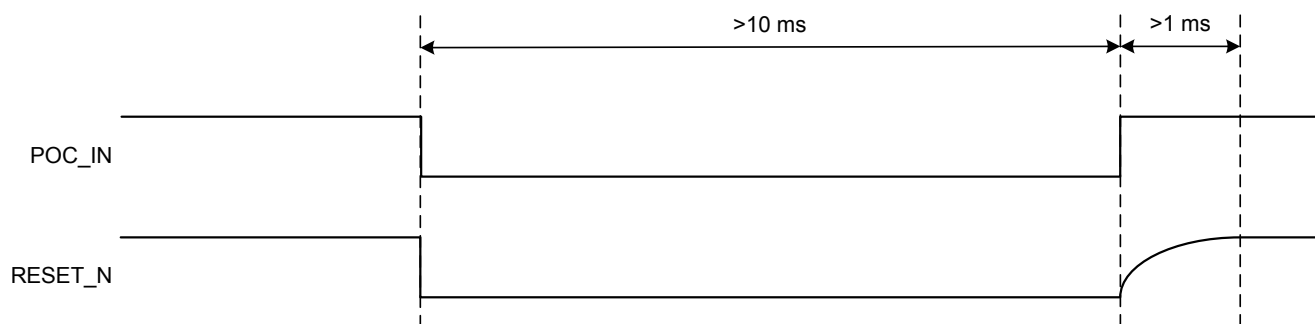

**Figure 7.2. External Reset via POC\_IN**

In the above timing diagrams, it is assumed that all supplies including VBATT are connected together. If they are not connected together and independently controlled, then the guidance below must be followed.

- **Case1:** POC is looped back and there is no external control for POC\_IN
  - All supplies can be enabled at the same time, if possible
  - If supplies cannot be enabled at the same time, the VBATT supplies should be powered up first and all other supplies should be powered on at least 1 ms before RESET\_N is high. The RC circuit controlling RESET\_N must be adjusted to provide the appropriate delay.
  - While powering down, supplies can be powered off simultaneously, or with VBATT the last to be disabled.
- **Case2:** POC is looped back and there is external control for POC\_IN during power-up / power-down.
  - All supplies can be enabled at the same time, or VBATT may be enabled before other supplies.
  - POC\_IN should be kept low for at least 600 us after all the supplies have settled.
  - On power-down, POC\_IN can be driven low before disabling the supplies. Supplies can be powered off simultaneously, or with VBATT the last to be disabled.

### 7.3.3 ULP Regulators

ULP (Ultra Low Power) regulators are used to power low power Always-ON digital and analog power management circuitry inside the IC. The ULP regulators include two high power LDOs, a Low power LDO, and a switched capacitor DC-DC regulator. These regulators operate directly off of UULP\_VBATT\_2.

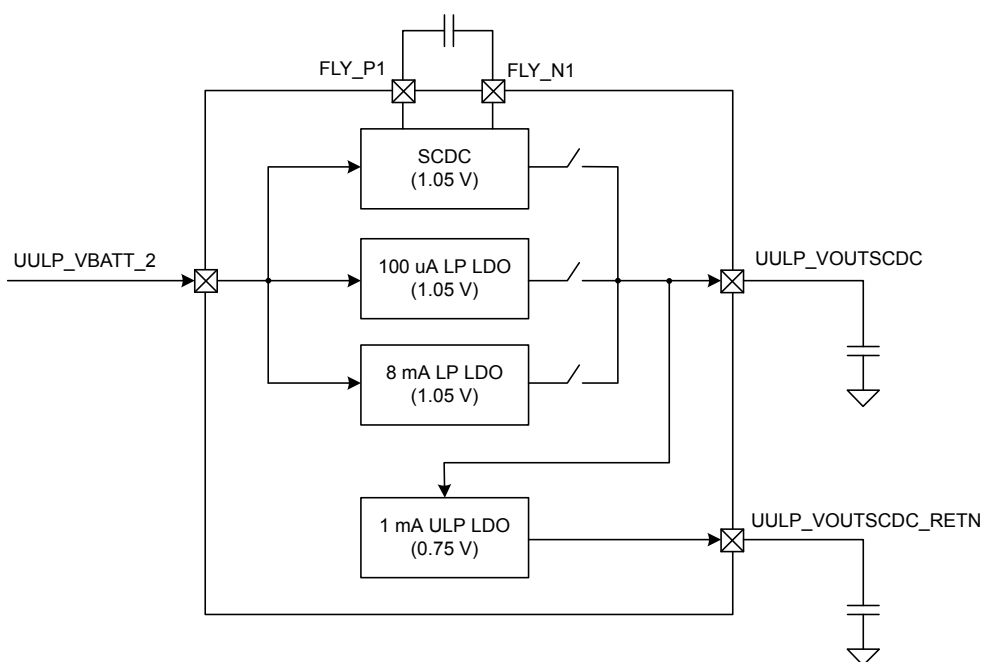

Figure 7.3. Block Diagram

### 7.3.3.1 SC-DCDC

SC-DCDC stands for a Switched Capacitor DC-DC regulator. It operates from UULP\_VBATT\_2 and generates a programmable output voltage. It has two major modes of operation, viz. LDO mode and DC-DC mode. And further each of these modes have a low power and high power option.

The IC starts up in the LDO mode and later switches to DC-DC Mode.

**Table 7.4. SC-DCDC - Electrical Specifications**

Parameter	Symbol	Test Condition	Min	Typ	Max	Unit
Input Voltage Range <sup>1</sup>	$V_{IN}$		1.71	—	3.63	V
Output Voltage at UULP_VOUTSCDC	$V_{OUTSCDC}$		—	1.05	—	V
Output Voltage at UULP_VOUTSCDC_RETN	$V_{OUTRETN}$		—	0.75	—	V

**Note:**

1. The ULP regulator switches from SC-DCDC mode to LDO mode for  $V_{in}$  lower than 2.4 V

### 7.3.4 Power Management Unit

This section describes and specifies the Power Management Unit solution for the mixed signal System on Chip (SoC).

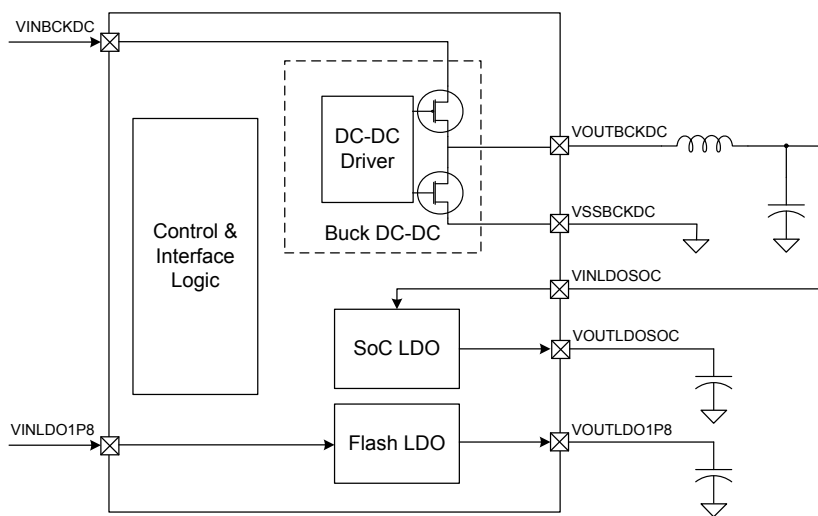

**Figure 7.4. Power Management Block Diagram**

#### Power Management Unit

The major features are

- 1.45 V DCDC switching converter
- 1.15 V LDO for SOC digital supply
- 1.8 V LDO for Flash supply

### 7.3.4.1 DCDC Switching Converter

- Power save mode at light load currents.
- 100% duty cycle for lowest dropout.
- Soft start

**Table 7.5. DCDC Switching Converter Electrical Specifications**

Parameter	Symbol	Test Condition	Min	Typ	Max	Unit
Input Supply Voltage (VINBCKDC)	$V_{in}$		1.71	3.3	3.63	V
Output Voltage Range (VOUTBCKDC)	$V_{out}$		1.35	1.45	1.6	V
Load current	$I_{load}$	Active mode	—	—	170	mA

### 7.3.4.2 SoC LDO Electrical Specifications

**Table 7.6. SoC LDO Electrical Specifications**

Parameter	Symbol	Test Condition	Min	Typ	Max	Unit
Input Supply Voltage (VINL-DOSOC)	$V_{in}$		1.35	1.45	1.55	V
Output Voltage Range (VOUTLDOSOC)	$V_{out}$		1.05	1.15	1.20	V
Load current	$I_{load}$		—	—	100	mA

### 7.3.4.3 Flash LDO Electrical Specifications - Regulation Mode

**Table 7.7. Flash LDO Electrical Specifications - Regulation Mode**

Parameter	Symbol	Test Condition	Min	Typ	Max	Unit
Input Supply Voltage (VINL-DO1P8)	$V_{in}$	Flash LDO in Regulation Mode	2.97	3.3	3.63	V
Output Voltage Range (VOUTLDO1P8)	$V_{out}$		1.75	1.88	1.95	V
Load current	$I_{load}$		—	—	48	mA
Line Regulation	$REG_{line}$	$V_{in}$ Changed from 2.97 V to 3.63 V	—	—	0.6	%
Load Regulation	$REG_{load}$	$I_{load}$ changed from 5 $\mu$ A to 48 mA	—	—	3	%

### 7.3.4.4 Flash LDO Electrical Specifications - Bypass Mode

**Table 7.8. Flash LDO Electrical Specifications - Bypass Mode**

Parameter	Symbol	Test Condition	Min	Typ	Max	Unit
Input Supply Voltage (VINL-DO1P8) <sup>1</sup>	V <sub>in</sub>	Flash LDO in Bypass Mode	1.71	1.8	1.98	V
On Resistance between V <sub>in</sub> and V <sub>out</sub>	R <sub>on</sub>		—	0.87	—	Ω
Voltage across the VIN and V <sub>out</sub> pin of the Flash LDO	V <sub>drop</sub>	Load = 48 mA (Max)	—	42	70	mV

**Note:**

- For higher load currents, the input supply should be increased to compensate the V<sub>drop</sub> across the R<sub>on</sub> of the pass transistor of Flash LDO.

### 7.3.5 Thermal Characteristics

**Table 7.9. Thermal Characteristics**

Package	Board	Parameter	Sym- bol	Test Condi- tion	Value	Unit
84 Pin DR-QFN (7 mm x 7 mm)	JEDEC - High Thermal Cond. (2s2p) <sup>1</sup>	Thermal Resistance, Junction to Ambient	Θ <sub>JA</sub>	Still Air	30	°C/W

**Note:**

- PCB: 76.2 mm x 114.3 mm x 1.6 mm (JEDEC High Effective); 2s2p = 2 signals, 2 planes.
- The absolute maximum device current when transmitting at highest transmit power will not exceed 400 mA.

### 7.3.6 Digital I/O Signals

**Table 7.10. Digital I/O Signals**

Parameter	Symbol	Test Condition	Min	Typ	Max	Unit
High level input voltage	V <sub>IH</sub>	IO_VDDx = 3.3 V	2	—	—	V
		IO_VDDx = 1.8 V	1.17	—	—	V
Low level input voltage	V <sub>IL</sub>	IO_VDDx = 3.3 V	—	—	0.8	V
		IO_VDDx = 1.8 V	—	—	0.63	V
Low level output voltage	V <sub>OL</sub>		—	—	0.4	V
High level output voltage	V <sub>OH</sub>		IO_VDDx - 0.4	—	—	V
Low level output current	I <sub>OL</sub>	GPIO_* and ULP_GPIO_* pins	2	4	12	mA
		UULP_GPIO_*	1	—	2	mA
High level output current	I <sub>OH</sub>	GPIO_* and ULP_GPIO_* pins	2	4	12	mA
		UULP_GPIO_*	1	—	2	mA

## 7.4 AC Characteristics

### 7.4.1 Clock Specifications

SiWN917 chipsets include the following clock options:

- Low frequency clock options for sleep manager and RTC
  - 32.768 kHz on-chip crystal oscillator for an external crystal at pins XTAL\_32KHZ\_P and XTAL\_32KHZ\_N. **Required for all power-sensitive Wi-Fi, BLE, and Coex use cases.**
  - Internal 32 kHz RC oscillator. Suitable only for applications with low timing accuracy requirements, and no critical timing. Typical accuracy is +/- 1.2%.
- High frequency clock options
  - 40 MHz on-chip crystal oscillator with external crystal at XTAL\_IN and XTAL\_OUT pins for RF reference
  - Internal RC oscillator, used during device boot-up
  - Internal high-frequency ring oscillator

#### 7.4.1.1 Low Frequency Clocks

Low-frequency clock selection can be done through software. The RC oscillator clock is not suited for high timing accuracy applications and may increase overall system current consumption in duty-cycled power modes.

**Table 7.11. 32 kHz RC Oscillator**

Parameter	Symbol	Test Condition	Min	Typ	Max	Unit
Oscillator Frequency	$f_{osc}$		—	32	—	kHz
Frequency variation across temperature	$f_{osc\_Acc}$		—	1.2	—	%

#### 32.768 kHz XTAL Oscillator

There is an option to use 32.768 kHz low-frequency XTAL clock with a crystal attached to the XTAL\_32KHZ\_P and XTAL\_32KHZ\_N pins. Below are the recommended external crystal specs that need to connect to the internal xtal oscillator.

**Table 7.12. 32.768 kHz XTAL Oscillator**

Parameter	Symbol	Test Condition	Min	Typ	Max	Unit
Oscillator Frequency <sup>1</sup>	$f_{osc}$		—	32.768	—	kHz
Drive Level	Drive		0.5	—	—	uW
Frequency Variation with Temp and Voltage <sup>2</sup>	$f_{osc\_Acc}$		—	+/-250	—	ppm
Equivalent series resistance	ESR		—	—	80	kΩ
Load capacitance range	$C_L$		4	—	12.5	pF

**Note:**

1. XTAL Oscillator specified for fundamental mode, parallel resonant crystal
2. Combined frequency offset must be below this limit, including temperature induced changes, tolerance, and the variance of load capacitances (load capacitor and parasitic trace impedance)

### 7.4.1.2 40 MHz Clock

The 40 MHz internal oscillator mode can be used by connecting a 40 MHz crystal between the pins XTAL\_P and XTAL\_N. Load capacitance is integrated inside the chipset and calibrated and the calibrated value can be stored in eFuse using calibration software.

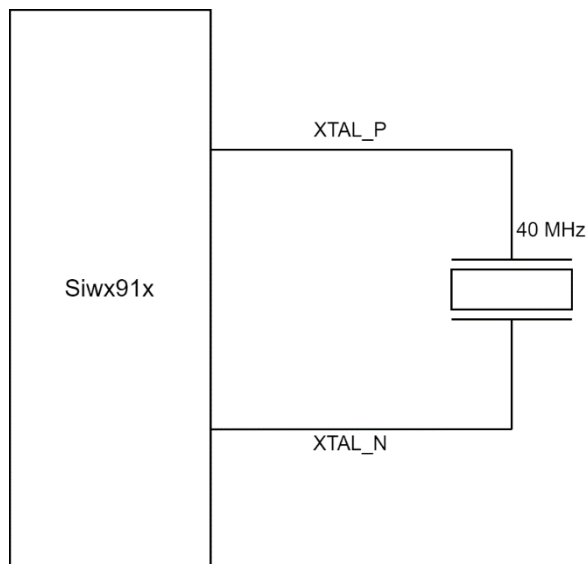

**Table 7.13. 40 MHz Crystal Specifications**

Parameter	Symbol	Test Condition	Min	Typ	Max	Unit
Oscillator Frequency <sup>1</sup>	$f_{osc}$		—	40	—	MHz
Drive Level	Drive		100	—	—	uW
Frequency Variation with Temp and Voltage	$f_{osc\_Acc}$		-20	—	20	ppm
Equivalent series resistance	ESR		—	—	60	$\Omega$
Load capacitance range	$C_L$		7	—	10	pF

**Note:**

- Oscillator specified for fundamental mode, parallel resonant crystal.
- Software has the default "Crystal Good Time" value for the recommended crystal part listed in Table 8.1. If a non-recommended crystal part is used, "Crystal Good time" value has to be determined as per Application Note [AN1436](#).

## 7.4.2 SDIO 2.0 Secondary

### 7.4.2.1 Full Speed Mode

Table 7.14. SDIO 2.0 Secondary Full Speed Mode

Parameter	Symbol	Test Condition	Min	Typ	Max	Unit
SDIO_CLK	$f_{\text{sdio\_clk}}$		—	—	25	MHz
SDIO_DATA, SDIO_CMD input setup time	$t_s$		4	—	—	ns
SDIO_DATA, SDIO_CMD input hold time	$t_h$		1.2	—	—	ns
SDIO_DATA, clock to output delay	$t_{\text{od}}$		—	—	13	ns
Output Load	$C_L$		5	—	10	pF

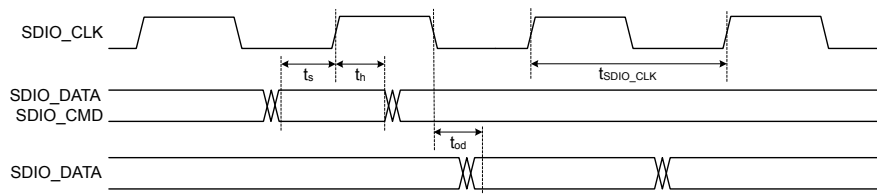

Figure 7.5. Interface Timing Diagram for SDIO 2.0 Secondary Full Speed Mode

### 7.4.2.2 High Speed Mode

Table 7.15. SDIO 2.0 Secondary High Speed Mode

Parameter	Symbol	Test Condition	Min	Typ	Max	Unit
SDIO_CLK	$f_{\text{sdio\_clk}}$		25	—	50	MHz
SDIO_DATA, input setup time	$t_s$		4	—	—	ns
SDIO_DATA, input hold time	$t_h$		1.2	—	—	ns
SDIO_DATA, clock to output delay	$t_{\text{od}}$		2.5	—	13	ns
Output Load	$C_L$		5	—	10	pF

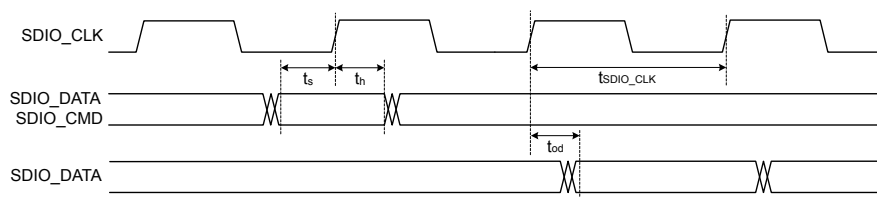

Figure 7.6. Interface Timing Diagram for SDIO 2.0 Secondary High Speed Mode

### 7.4.3 HSPI Secondary

#### 7.4.3.1 Low Speed Mode

Table 7.16. HSPI Secondary Low Speed Mode

Parameter	Symbol	Test Condition	Min	Typ	Max	Unit
HSPI_CLK	$f_{hspi}$		0	—	25	MHz
HSPI_CSN to output delay	$t_{cs}$		—	—	7.5	ns
HSPI_CSN to input setup time	$t_{cst}$		4.5	—	—	ns
HSPI_MOSI, input setup time	$t_s$		1.4	—	—	ns
HSPI_MOSI, input hold time	$t_h$		1.5	—	—	ns
HSPI_MISO, clock to output delay	$t_{od}$		—	—	8.75	ns
Output Load	$C_L$		5	—	10	pF

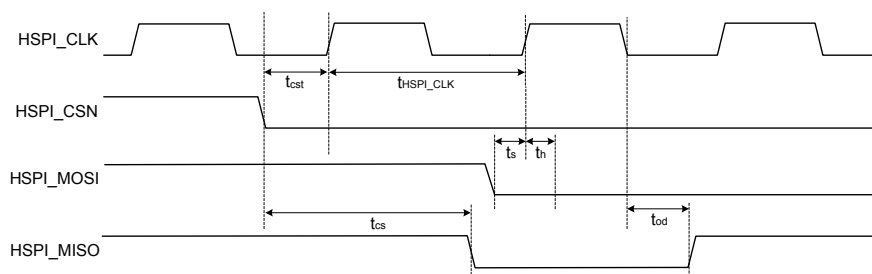

Figure 7.7. Interface Timing Diagram for HSPI Secondary Low Speed Mode

In low speed mode, HSPI\_MISO data is driven on the falling edge of HSPI\_CLK, and HSPI\_MOSI is read on the rising edge of HSPI\_CLK.

7.4.3.2 High Speed Mode

Table 7.17. HSPI Secondary High Speed Mode

Parameter	Symbol	Test Condition	Min	Typ	Max	Unit
HSPI_CLK	$f_{\text{hspi}}$		25	—	80	MHz
HSPI_CSN to output delay	$t_{\text{cs}}$		—	—	7.5	ns
HSPI_CSN to input setup time	$t_{\text{cst}}$		4.5	—	—	ns
HSPI_MOSI, input setup time	$t_{\text{s}}$		1.4	—	—	ns
HSPI_MOSI, input hold time	$t_{\text{h}}$		1.4	—	—	ns
HSPI_MISO, clock to output delay	$t_{\text{od}}$		1.5	—	8.75	ns
Output Load	$C_{\text{L}}$		5	—	10	pF

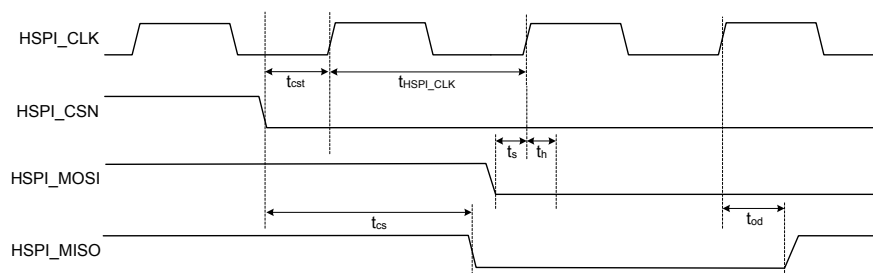

Figure 7.8. Interface Timing Diagram for HSPI Secondary High Speed Mode

In high speed mode, HSPI\_MISO data is driven on the rising edge of HSPI\_CLK, and HSPI\_MOSI is read on the rising edge of HSPI\_CLK.

### 7.4.3.3 Ultra High Speed Mode

**Table 7.18. HSPI Secondary Ultra High Speed Mode**

Parameter	Symbol	Test Condition	Min	Typ	Max	Unit
HSPI_CLK	$f_{\text{hspi}}$		80	—	100	MHz
HSPI_MOSI, input setup time	$t_s$		1.4	—	—	ns
HSPI_MOSI, input hold time	$t_h$		1.4	—	—	ns
HSPI_MISO, clock to output delay	$t_{od}$		1.5	—	8.75	ns
Output Load	$C_L$		5	—	10	pF

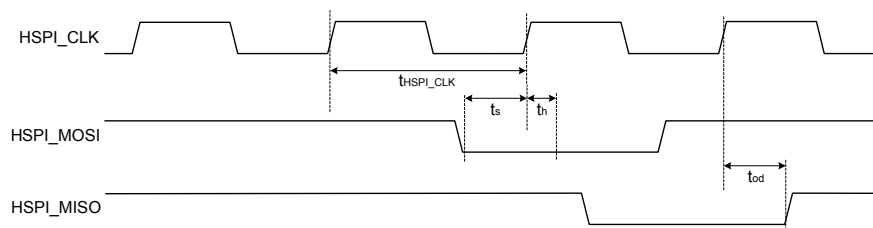

**Figure 7.9. Interface Timing Diagram for HSPI Secondary Ultra High Speed Mode**

In ultra high speed mode, HSPI\_MISO data is driven on the rising edge of HSPI\_CLK, and HSPI\_MOSI is read on the rising edge of HSPI\_CLK.

### 7.4.4 UART

**Table 7.19. UART**

Parameter	Symbol	Test Condition	Min	Typ	Max	Unit
Baud Rate	$f_{\text{BAUD}}$		—	—	921600	bps

### 7.4.5 GPIO Pins

**Table 7.20. GPIO Pins**

Parameter	Symbol	Test Condition	Min	Typ	Max	Unit
Rise time	$t_{rf}$	Pin configured as output	1	—	5	ns
Fall time	$t_{ff}$	Pin configured as output	0.9	—	5	ns
Rise time	$t_r$	Pin configured as input	0.3	—	1.3	ns
Fall time	$t_f$	Pin configured as input	0.2	—	1.2	ns

## 7.4.6 In-Package Flash Memory

**Table 7.21. In-Package Flash Memory**

Parameter	Symbol	Test Condition	Min	Typ	Max	Unit
Endurance	N <sub>endu</sub>	Sector erase/program	10000	—	—	cycles
		Page erase/program, page in large sector	10000	—	—	cycles
		Page erase/program, page in small sector	10000	—	—	cycles
Retention time	t <sub>ret</sub>	Powered	10	—	—	years
		Unpowered	10	—	—	years
Block Erase time (32 KB)	t <sub>er</sub>	Page, sector or multiple consecutive sectors	—	150	1400	ms
Page programming time	t <sub>prog</sub>		—	0.5	3	ms
Chip Erase time	t <sub>ce</sub>		—	20	65	s

## 7.5 RF Characteristics

In the sub-sections below,

- All numbers are measured at T<sub>A</sub> = 25°C, PA2G\_AVDD = VINBCKDC = 3.3 V using an external 40 MHz crystal, unless otherwise stated.
- Please refer to [8. Reference Schematics, BOM and Layout Guidelines](#). As shown in [Figure 8.4. Option 1: RF Frontend with External Switch](#), there are three RF pins at the IC: RF\_TX, RF\_RX, and RF\_BLETX. The RF front end for testing includes the matching network, RF switch and a band-pass filter. Typical front-end loss is about 2 dB. Silicon Labs recommends using the suggested reference design to meet these specs.
- All reported Receiver Sensitivity and Transmit Power numbers are based on the RF front end option shown in [Figure 8.4. Option 1: RF Frontend with External Switch](#). The value at the antenna port (ANT1) will be based on front end loss, which is typically 2 dB lower than pins RF1, RF2, and RF3 of the RF switch (SW2). Using the internal switch option incurs 1-1.5 dBm performance degradation, unless otherwise specified.
- Supported WLAN channels for different regions include:
  - US: Channels 1 (2412 MHz) through 11 (2462 MHz)
  - Europe: Channels 1 (2412 MHz) through 13 (2472 MHz)
  - Japan: Channels 1 (2412 MHz) through 14 (2484 MHz), Channel 14 supports 1 and 2 Mbps data rates only

## 7.5.1 WLAN 2.4 GHz Transmitter Characteristics

### 7.5.1.1 WLAN 2.4 GHz Transmitter Characteristics with 3.3 V Supply

Unless otherwise indicated, typical conditions are:  $T_A = 25\text{ }^\circ\text{C}$ . PA2G\_AVDD = VINBCKDC = 3.3 V. Remaining supplies are at typical operating conditions. Parameters are referred at IC pin (RF\_TX).

**Table 7.22. WLAN 2.4 GHz Transmitter Characteristics with 3.3 V Supply**

Parameter	Symbol	Test Condition	Min	Typ	Max	Unit
Transmit Power for 20 MHz Bandwidth, with EVM limits <sup>1</sup> <sub>2 3</sub>	POUT	802.11b 1 Mbps DSSS, EVM< -9 dB	—	19	—	dBm
		802.11b 11 Mbps CCK, EVM< -9 dB	—	19	—	dBm
		802.11g 6 Mbps OFDM, EVM< -5 dB <sup>4</sup>	—	19.5	—	dBm
		802.11g 54 Mbps OFDM, EVM< -25 dB <sup>4</sup>	—	15.5	—	dBm
		802.11n HT20 MCS0 Mixed Mode, EVM< -5 dB <sup>4</sup>	—	19.5	—	dBm
		802.11n HT20 MCS7 Mixed Mode, EVM< -27 dB <sup>4</sup>	—	14.5	—	dBm
		802.11ax HE20 MCS0 SU, EVM< -5 dB <sup>5 4</sup>	—	18.5	—	dBm
		802.11ax HE20 MCS7 SU, EVM< -27 dB <sup>5 4</sup>	—	13	—	dBm
Power variation across channels <sup>6</sup>	POUT <sub>VAR_CH</sub>		—	2	—	dB
Power variation across temperature <sup>7</sup>	POUT <sub>VAR_T</sub>	-40 to +85 °C	—	3	—	dB

**Note:**

1. Transmit power listed in this table is average power across channels 1 to 13. Customers should calibrate crystal error and follow application note guidelines to achieve regulatory compliance.
2. TX power in edge channels will be limited by Restricted band edge in the FCC region.
3. Refer to the Wi-Fi Gain Table section in [AN1437](#) for details on TX power backoff for compliance with regulatory limits.
4. 11ax TB\_PPDU @ Channels(1-13) TX power will be limited by antenna conducted output power test case (dBm/MHz) in MIC region.
5. 11ax TB\_PPDU TX power will be limited by PSD in the ETSI region.
6. This variation is measured independently and is not derived from or referenced to the typical values listed in the table.
7. Variation is noted at channel-6. This variation is measured independently and is not derived from or referenced to the typical values listed in the table.

### 7.5.2 WLAN 2.4 GHz Receiver Characteristics on HP RF Chain

Unless otherwise indicated, typical conditions are:  $T_A = 25\text{ }^\circ\text{C}$ . PA2G\_AVDD = VINBCKDC = 3.3 V. Remaining supplies are at typical operating conditions. Parameters are referred at IC pin RF\_RX

**Table 7.23. WLAN 2.4 GHz Receiver Characteristics on HP RF Chain**

Parameter	Symbol	Test Condition	Min	Typ	Max	Unit
Sensitivity for 20 MHz Bandwidth <sup>1 2 3</sup>	SENS	802.11b 1 Mbps DSSS <sup>4</sup>	—	-97.5	—	dBm
		802.11b 11 Mbps CCK <sup>4</sup>	—	-88	—	dBm
		802.11g 6 Mbps OFDM <sup>5</sup>	—	-93	—	dBm
		802.11g 54 Mbps OFDM <sup>5</sup>	—	-76.5	—	dBm
		802.11n HT20 MCS0 Mixed Mode <sup>6</sup>	—	-92	—	dBm
		802.11n HT20 MCS7 Mixed Mode <sup>6</sup>	—	-73	—	dBm
		802.11ax HE20 MCS0 SU <sup>7</sup>	—	-91.5	—	dBm
		802.11ax HE20 MCS7 SU <sup>7</sup>	—	-72	—	dBm
		802.11ax HE20 MCS0 ER <sup>7</sup>	—	-92.5	—	dBm
Maximum Input Level for PER below 10%	RX <sub>SAT</sub>	802.11b	—	3	—	dBm
		802.11g	—	-2.5	—	dBm
		802.11n	—	-4.5	—	dBm
		802.11ax	—	-2.5	—	dBm
RSSI Accuracy Range <sup>11</sup>	RSSI <sub>RNG</sub>	Input level from +2 dBm to -87 dBm	—	+/-4	—	dB
Adjacent Channel Interference <sup>8</sup>	ACI	802.11b 1 Mbps DSSS <sup>4 9</sup>	—	43	—	dB
		802.11b 11 Mbps CCK <sup>4 9</sup>	—	35	—	dB
		802.11g 6 Mbps OFDM <sup>5 10</sup>	—	38	—	dB
		802.11g 54 Mbps OFDM <sup>5 10</sup>	—	18	—	dB
		802.11n HT20 MCS0 Mixed Mode <sup>6 10</sup>	—	32	—	dB
		802.11n HT20 MCS7 Mixed Mode <sup>6 10</sup>	—	10	—	dB
		802.11ax HE20 MCS0 SU <sup>7 10</sup>	—	20	—	dB
		802.11ax HE20 MCS7 SU <sup>7 10</sup>	—	3	—	dB

Parameter	Symbol	Test Condition	Min	Typ	Max	Unit
Alternate Adjacent Channel Interference <sup>8</sup>	AACI	802.11b 1 Mbps DSSS <sup>4 9</sup>	—	49	—	dB
		802.11b 11 Mbps CCK <sup>4 9</sup>	—	42	—	dB
		802.11g 6 Mbps OFDM <sup>5 10</sup>	—	49	—	dB
		802.11g 54 Mbps OFDM <sup>5 10</sup>	—	27	—	dB
		802.11n HT20 MCS0 Mixed Mode <sup>6 10</sup>	—	48	—	dB
		802.11n HT20 MCS7 Mixed Mode <sup>6 10</sup>	—	26	—	dB
		802.11ax HE20 MCS0 SU <sup>7 10</sup>	—	48	—	dB
		802.11ax HE20 MCS7 SU <sup>7 10</sup>	—	25	—	dB

**Note:**

1. RX Sensitivity Variation within these channels (1, 2, 3, 4, 5, 9, and 10) is up to 2dB at typical / room temperature. These variations are measured independently and are not derived from or referenced to the typical values listed in the table.
2. RX Sensitivity may be degraded for these channels (6, 7, 8, 11, 12 and 13) by up to 3dB from the min value of all channels 1 to 13, at typical / room temperature. These variations are measured independently and are not derived from or referenced to the typical values listed in the table.
3. Sensitivity variation across temperature -40 °C to 85 °C is up to 3 dB at channel-6. These variations are measured independently and are not derived from or referenced to the typical values listed in the table.
4. 802.11b, Packet size is 1024 bytes, < 8% PER limit.
5. 802.11g, Packet size is 1024 bytes, < 10% PER limit.
6. 802.11n, Packet size is 4096 bytes, < 10% PER limit.
7. 802.11ax, Packet size is 4096 bytes, < 10% PER limit, Carrier modulation is non-DCM
8. ACI / AACI is calculated as Interferer Power(dBm)- Inband power(dBm)
9. Desired signal power is 6 dB above standard defined sensitivity level
10. Desired signal power is 3 dB above standard defined sensitivity level
11. RSSI error may increase up to ±10 dB for Receive input levels below -87 dBm.

### 7.5.3 WLAN 2.4 GHz Receiver Characteristics on LP RF Chain

Unless otherwise indicated, typical conditions are:  $T_A = 25\text{ }^\circ\text{C}$ . PA2G\_AVDD = VINBCKDC = 3.3 V. Remaining supplies are at typical operating conditions. Parameters are referred at IC pin RF\_RX

**Table 7.24. WLAN 2.4 GHz Receiver Characteristics on LP RF Chain**

Parameter	Symbol	Test Condition	Min	Typ	Max	Unit
Sensitivity for 20 MHz Bandwidth <sup>1 2 3</sup>	SENS	802.11b 1 Mbps DSSS <sup>4</sup>	—	-97	—	dBm
		802.11b 11 Mbps CCK <sup>4</sup>	—	-87.5	—	dBm
		802.11g 6 Mbps OFDM <sup>5</sup>	—	-92.5	—	dBm
		802.11g 36 Mbps OFDM <sup>5</sup>	—	-81.5	—	dBm
		802.11n HT20 MCS0 Mixed Mode <sup>6</sup>	—	-91.5	—	dBm
		802.11n HT20 MCS4 Mixed Mode <sup>6</sup>	—	-80.5	—	dBm
Maximum Input Level for PER below 10%	RX <sub>SAT</sub>	802.11b	—	-8	—	dBm
		802.11g	—	-0.5	—	dBm
		802.11n	—	-1	—	dBm
RSSI Accuracy Range <sup>10</sup>	RSSI <sub>RNG</sub>	Input level from +2 dBm to -83 dBm	—	+/-4	—	dB
Adjacent Channel Interference <sup>7</sup>	ACI	802.11b 1 Mbps DSSS <sup>4 8</sup>	—	43	—	dB
		802.11b 11 Mbps CCK <sup>4 8</sup>	—	36	—	dB
		802.11g 6 Mbps OFDM <sup>5 9</sup>	—	38	—	dB
		802.11g 36 Mbps OFDM <sup>5 9</sup>	—	25	—	dB
		802.11n HT20 MCS0 Mixed Mode <sup>6 9</sup>	—	32	—	dB
		802.11n HT20 MCS4 Mixed Mode <sup>6 9</sup>	—	18	—	dB

Parameter	Symbol	Test Condition	Min	Typ	Max	Unit
Alternate Adjacent Channel Interference <sup>7</sup>	AACI	802.11b 1 Mbps DSSS <sup>4 8</sup>	—	46	—	dB
		802.11b 11 Mbps CCK <sup>4 8</sup>	—	40	—	dB
		802.11g 6 Mbps OFDM <sup>5 9</sup>	—	43	—	dB
		802.11g 36 Mbps OFDM <sup>5 9</sup>	—	31	—	dB
		802.11n HT20 MCS0 Mixed Mode <sup>6 9</sup>	—	43	—	dB
		802.11n HT20 MCS4 Mixed Mode <sup>6 9</sup>	—	30	—	dB

**Note:**

1. RX Sensitivity Variation within these channels (1, 2, 3, 4, 5, 9, and 10) is up to 2dB at typical / room temperature. These variations are measured independently and are not derived from or referenced to the typical values listed in the table.
2. RX Sensitivity may be degraded for these channels (6, 7, 8, 11, 12 and 13) by up to 3dB from the min value of all channels 1 to 13, at typical / room temperature. These variations are measured independently and are not derived from or referenced to the typical values listed in the table.
3. Sensitivity variation across temperature -40 °C to 85 °C is up to 3 dB at channel-6. These variations are measured independently and are not derived from or referenced to the typical values listed in the table.
4. 802.11b, Packet size is 1024 bytes, < 8% PER limit.
5. 802.11g, Packet size is 1024 bytes, < 10% PER limit.
6. 802.11n, Packet size is 4096 bytes, < 10% PER limit.
7. ACI / AACI is calculated as Interferer Power(dBm)- Inband power(dBm)
8. Desired signal power is 6 dB above standard defined sensitivity level
9. Desired signal power is 3 dB above standard defined sensitivity level
10. RSSI error may increase up to ±10 dB for Receive input levels below -83 dBm.

### 7.5.4 Bluetooth Transmitter Characteristics on High-Performance (HP) RF Chain

Unless otherwise indicated, typical conditions are:  $T_A = 25\text{ }^\circ\text{C}$ . PA2G\_AVDD = VINBCKDC = 3.3 V. Remaining supplies are at typical operating conditions. Parameters are referred at IC pin (RF\_TX).

**Table 7.25. Bluetooth Transmitter Characteristics on High-Performance (HP) RF Chain**

Parameter	Symbol	Test Condition	Min	Typ	Max	Unit
Transmit Power <sup>1 2</sup>	POUT	LE 1 Mbps <sup>3</sup>	—	19	—	dBm
		LE 2 Mbps <sup>5</sup>	—	19	—	dBm
		LR 500 kbps <sup>4</sup>	—	19	—	dBm
		LR 125 kbps <sup>4</sup>	—	19	—	dBm
Power variation across channels <sup>6</sup>	POUT <sub>VAR_CH</sub>		—	2	—	dB
Power variation across temperature <sup>7</sup>	POUT <sub>VAR_T</sub>	-40 to +85 °C	—	3	—	dB
Adjacent Channel Power  M-N  = 2	ACP <sub>eq2</sub>	LE	—	-25	—	dBm
Adjacent Channel Power  M-N  > 2	ACP <sub>gt2</sub>	LE	—	-31	—	dBm
BLE Modulation Characteristics at 1 Mbps	MOD <sub>CHAR</sub>	$\Delta f_1$ Avg	—	250	—	kHz
		$\Delta f_2$ Max	—	250	—	kHz
		$\Delta f_2$ Avg/ $\Delta f_1$ Avg	—	1.3	—	

**Note:**

1. ETSI Max Power should be limited to 10 dBm because device falls under DTS, non-adaptive
2. Refer to the BLE Gain Table section in [AN1437](#) for details on TX power backoff for compliance with regulatory limits.
3. In FCC, for 1 Mbps data rates, in channels 2476 - 2480 MHz, TX output power will be limited by band edge.
4. In FCC - LR 125 kbps, 500 kbps Max Power should be limited to 12 dBm to meet PSD requirement because, device falls under DTS, non-adaptive
5. Channel 2480 MHz is not supported in 2 Mbps
6. This variation is measured independently and is not derived from or referenced to the typical values listed in the table.
7. Variation is noted at channel-6. This variation is measured independently and is not derived from or referenced to the typical values listed in the table.

### 7.5.5 Bluetooth Transmitter Characteristics on Low-Power (LP) 8 dBm RF Chain

Unless otherwise indicated, typical conditions are:  $T_A = 25\text{ }^\circ\text{C}$ . PA2G\_AVDD = VINBCKDC = 3.3 V. Remaining supplies are at typical operating conditions. Parameters are referred at IC pin (RF\_BLETX).

**Table 7.26. Bluetooth Transmitter Characteristics on Low-Power (LP) 8 dBm RF Chain**

Parameter	Symbol	Test Condition	Min	Typ	Max	Unit
Transmit Power <sup>1</sup>	POUT	LE 1 Mbps	—	8	—	dBm
		LE 2 Mbps <sup>2</sup>	—	8	—	dBm
		LR 500 kbps	—	8	—	dBm
		LR 125 kbps	—	8	—	dBm
Power variation across channels <sup>3</sup>	POUT <sub>VAR_CH</sub>		—	2	—	dB
Power variation across temperature <sup>4</sup>	POUT <sub>VAR_T</sub>	-40 to +85 °C	—	3	—	dB
Adjacent Channel Power  M-N  = 2	ACP <sub>eq2</sub>	LE	—	-32	—	dBm
Adjacent Channel Power  M-N  > 2	ACP <sub>gt2</sub>	LE	—	-36	—	dBm
BLE Modulation Characteristics at 1 Mbps	MOD <sub>CHAR</sub>	Δf1 Avg	—	248	—	kHz
		Δf2 Max	—	249	—	kHz
		Δf2 Avg/Δf1 Avg	—	1.3	—	kHz

**Note:**

1. Refer to the BLE Gain Table section in [AN1437](#) for details on TX power backoff for compliance with regulatory limits.
2. Channel 2480 MHz is not supported in 2 Mbps.
3. This variation is measured independently and is not derived from or referenced to the typical values listed in the table.
4. Variation is noted at channel-6. This variation is measured independently and is not derived from or referenced to the typical values listed in the table.

### 7.5.6 Bluetooth Transmitter Characteristics on Low-Power (LP) 0 dBm RF Chain

Unless otherwise indicated, typical conditions are:  $T_A = 25\text{ }^\circ\text{C}$ . PA2G\_AVDD = VINBCKDC = 3.3 V. Remaining supplies are at typical operating conditions. Parameters are referred at IC pin (RF\_RX).

**Table 7.27. Bluetooth Transmitter Characteristics on Low-Power (LP) 0 dBm RF Chain**

Parameter	Symbol	Test Condition	Min	Typ	Max	Unit
Transmit Power	POUT	LE 1 Mbps	—	-0.5	—	dBm
		LE 2 Mbps <sup>1</sup>	—	-0.5	—	dBm
		LR 500 kbps	—	-0.5	—	dBm
		LR 125 kbps	—	-0.5	—	dBm
Power variation across channels <sup>2</sup>	POUT <sub>VAR_CH</sub>		—	2	—	dB
Power variation across temperature <sup>3</sup>	POUT <sub>VAR_T</sub>	-40 to +85 °C	—	2	—	dB
Adjacent Channel Power  M-N  = 2	ACP <sub>eq2</sub>	LE	—	-41	—	dBm
Adjacent Channel Power  M-N  > 2	ACP <sub>gt2</sub>	LE	—	-47	—	dBm
BLE Modulation Characteristics	MOD <sub>CHAR</sub>	Δf1 Avg	—	248	—	kHz
		Δf2 Max	—	249	—	kHz
		Δf2 Avg/Δf1 Avg	—	1.3	—	kHz

**Note:**

1. Channel 2480 MHz is not supported in 2 Mbps.
2. This variation is measured independently and is not derived from or referenced to the typical values listed in the table.
3. Variation is noted at channel-6. This variation is measured independently and is not derived from or referenced to the typical values listed in the table.

### 7.5.7 Bluetooth Receiver Characteristics for 1 Mbps Data Rate

Unless otherwise indicated, specifications apply to both HP and LP chains. Typical conditions are:  $T_A = 25\text{ }^\circ\text{C}$ , PA2G\_AVDD = VINBCKDC = 3.3 V, remaining supplies are at typical operating conditions, packet length is 37 bytes, parameters are referred at IC pin RF\_RX

**Table 7.28. Bluetooth Receiver Characteristics for 1 Mbps Data Rate**

Parameter	Symbol	Test Condition	Min	Typ	Max	Unit
Max usable receiver input level	RX <sub>SAT</sub>	Signal is reference signal, 255 byte payload, BER = 0.017%, HP Chain	—	2	—	dBm
		Signal is reference signal, 255 byte payload, BER = 0.017%, LP Chain	—	-2	—	dBm
Sensitivity <sup>1 2</sup>	SENS	Signal is reference signal, 37 byte payload, BER = 0.1%	—	-96	—	dBm
		Signal is reference signal, 255 byte payload, BER = 0.017%	—	-94	—	dBm
Signal to co-channel interferer <sup>3</sup>	C/I <sub>CC</sub>	(see notes) <sup>4 5</sup>	—	-12	—	dB
N ± 1 Adjacent channel selectivity <sup>3</sup>	C/I <sub>1</sub>	Interferer is reference signal at +1 MHz offset <sup>4 6 5 7</sup>	—	-6	—	dB
		Interferer is reference signal at -1 MHz offset <sup>4 6 5 7</sup>	—	-4	—	dB
N ± 2 Alternate channel selectivity <sup>3</sup>	C/I <sub>2</sub>	Interferer is reference signal at +2 MHz offset <sup>4 6 5 7</sup>	—	19	—	dB
		Interferer is reference signal at -2 MHz offset <sup>4 6 5 7</sup>	—	24	—	dB
N ± 3 Alternate channel selectivity <sup>3</sup>	C/I <sub>3</sub>	Interferer is reference signal at +3 MHz offset <sup>4 6 5 7</sup>	—	20	—	dB
		Interferer is reference signal at -3 MHz offset <sup>4 6 5 7</sup>	—	31	—	dB
N ≥   ± 4  Alternate channel selectivity <sup>3</sup>	C/I <sub>4</sub>	Interferer is reference signal at ≥   ± 4  MHz offset <sup>4 6 5 7</sup>	—	33	—	dB
Selectivity to image frequency <sup>3</sup>	C/I <sub>IM</sub>	Interferer is reference signal at image frequency <sup>4 5 7 8</sup>	—	17	—	dB

Parameter	Symbol	Test Condition	Min	Typ	Max	Unit
Selectivity to image frequency $\pm 1$ MHz <sup>3</sup>	$C/I_{IM\_1}$	Interferer is reference signal at image frequency +1 MHz <sup>4 5 7 8</sup>	—	29	—	dB
		Interferer is reference signal at image frequency -1 MHz <sup>4 5 7 8</sup>	—	20	—	dB

**Note:**

1. Sensitivities may be degraded for channels 19, 39 by up to 2 dB from the min value of all channels 0 to 39, at typical/room temperature.
2. Sensitivity variation across temperature -40 °C to 85 °C is up to 4 dB at channel-19. These variations are measured independently and are not derived from or referenced to the typical values listed in the table.
3. C/I is calculated as Interferer Power(dBm)- Inband power(dBm)
4. 0.1% BER, 37 byte packet size
5. Desired signal = -67 dBm
6. Desired frequency  $2402 \text{ MHz} \leq F_c \leq 2480 \text{ MHz}$
7. With allowed exceptions
8. Image frequency is at +4 MHz offset

### 7.5.8 Bluetooth Receiver Characteristics for 2 Mbps Data Rate

Unless otherwise indicated, specifications apply to both HP and LP chains. Typical conditions are:  $T_A = 25\text{ }^\circ\text{C}$ , PA2G\_AVDD = VINBCKDC = 3.3 V, remaining supplies are at typical operating conditions, packet length is 37 bytes, parameters are referred at IC pin RF\_RX

**Table 7.29. Bluetooth Receiver Characteristics for 2 Mbps Data Rate**

Parameter	Symbol	Test Condition	Min	Typ	Max	Unit
Max usable receiver input level	RX <sub>SAT</sub>	Signal is reference signal, 255 byte payload, BER = 0.017%, HP Chain	—	2	—	dBm
		Signal is reference signal, 255 byte payload, BER = 0.017%, LP Chain	—	-6	—	dBm
Sensitivity <sup>1 2</sup>	SENS	Signal is reference signal, 37 byte payload, BER = 0.1%	—	-93	—	dBm
		Signal is reference signal, 255 byte payload, BER = 0.017%	—	-91	—	dBm
Signal to co-channel interferer <sup>3</sup>	C/I <sub>CC</sub>	(see notes) <sup>4 5</sup>	—	-10	—	dB
N ± 1 Adjacent channel selectivity <sup>3</sup>	C/I <sub>1</sub>	Interferer is reference signal at +2 MHz offset <sup>4 6 5 7</sup>	—	5	—	dB
		Interferer is reference signal at -2 MHz offset <sup>4 6 5 7</sup>	—	1	—	dB
N ± 2 Alternate channel selectivity <sup>3</sup>	C/I <sub>2</sub>	Interferer is reference signal at +4 MHz offset <sup>4 6 5 7</sup>	—	14	—	dB
		Interferer is reference signal at -4 MHz offset <sup>4 6 5 7</sup>	—	20	—	dB
Selectivity to image frequency <sup>3</sup>	C/I <sub>IM</sub>	Interferer is reference signal at image frequency <sup>4 5 7 8</sup>	—	14	—	dB
Selectivity to image frequency ± 2 MHz <sup>3</sup>	C/I <sub>IM_2</sub>	Interferer is reference signal at image frequency +2 MHz <sup>4 5 7 8</sup>	—	24	—	dB
		Interferer is reference signal at image frequency -2 MHz <sup>4 5 7 8</sup>	—	5	—	dB

**Note:**

- Sensitivities may be degraded for channels 19, 39 by up to 2 dB from the min value of all channels 0 to 39, at typical/room temperature.
- Sensitivity variation across temperature -40 °C to 85 °C is up to 4 dB at channel-19. These variations are measured independently and are not derived from or referenced to the typical values listed in the table.
- C/I is calculated as Interferer Power(dBm)- Inband power(dBm)
- 0.1% BER, 37 byte packet size
- Desired signal = -67 dBm
- Desired frequency 2402 MHz ≤ Fc ≤ 2480 MHz
- With allowed exceptions
- Image frequency is at +4 MHz offset

### 7.5.9 Bluetooth Receiver Characteristics for 125 kbps Data Rate

Unless otherwise indicated, specifications apply to both HP and LP chains. Typical conditions are:  $T_A = 25\text{ }^\circ\text{C}$ , PA2G\_AVDD = VINBCKDC = 3.3 V, remaining supplies are at typical operating conditions, packet length is 37 bytes, parameters are referred at IC pin RF\_RX

**Table 7.30. Bluetooth Receiver Characteristics for 125 kbps Data Rate**

Parameter	Symbol	Test Condition	Min	Typ	Max	Unit
Max usable receiver input level	RX <sub>SAT</sub>	Signal is reference signal, 255 byte payload, BER = 0.017%, HP Chain	—	3	—	dBm
		Signal is reference signal, 255 byte payload, BER = 0.017%, LP Chain	—	0	—	dBm
Sensitivity <sup>1 2</sup>	SENS	Signal is reference signal, 37 byte payload, BER = 0.1%	—	-107	—	dBm
		Signal is reference signal, 255 byte payload, BER = 0.017%	—	-106	—	dBm

**Note:**

- Sensitivities may be degraded for channels 19, 39 by up to 2 dB in External Switch configuration (Figure 8.4) and up to 8 dB in Internal Switch configuration (Figure 8.5), from the min value of all channels 0 to 39, at typical/room temperature.
- Sensitivity variation across temperature -40 °C to 85 °C is up to 4 dB at channel-19. These variations are measured independently and are not derived from or referenced to the typical values listed in the table.

### 7.5.10 Bluetooth Receiver Characteristics for 500 kbps Data Rate

Unless otherwise indicated, specifications apply to both HP and LP chains. Typical conditions are:  $T_A = 25\text{ }^\circ\text{C}$ , PA2G\_AVDD = VINBCKDC = 3.3 V, remaining supplies are at typical operating conditions, packet length is 37 bytes, parameters are referred at IC pin RF\_RX

**Table 7.31. Bluetooth Receiver Characteristics for 500 kbps Data Rate**

Parameter	Symbol	Test Condition	Min	Typ	Max	Unit
Max usable receiver input level	RX <sub>SAT</sub>	Signal is reference signal, 255 byte payload, BER = 0.017%, HP Chain	—	3	—	dBm
		Signal is reference signal, 255 byte payload, BER = 0.017%, LP Chain	—	0	—	dBm
Sensitivity <sup>1 2</sup>	SENS	Signal is reference signal, 37 byte payload, BER = 0.1%	—	-102.5	—	dBm
		Signal is reference signal, 255 byte payload, BER = 0.017%	—	-101.5	—	dBm

**Note:**

- Sensitivities may be degraded for channels 19, 39 by up to 2 dB in External Switch configuration (Figure 8.4) and up to 8 dB in Internal Switch configuration (Figure 8.5), from the min value of all channels 0 to 39, at typical/room temperature.
- Sensitivity variation across temperature -40 °C to 85 °C is up to 4 dB at channel-19. These variations are measured independently and are not derived from or referenced to the typical values listed in the table.

## 7.6 Typical Current Consumption

Figure 7.10. Supply Connection for Current Measurements shows the supply connection and measurement point for supply current numbers in this section. A 32.768 kHz crystal is used at pins XTAL\_32KHZ\_P and XTAL\_32KHZ\_N.

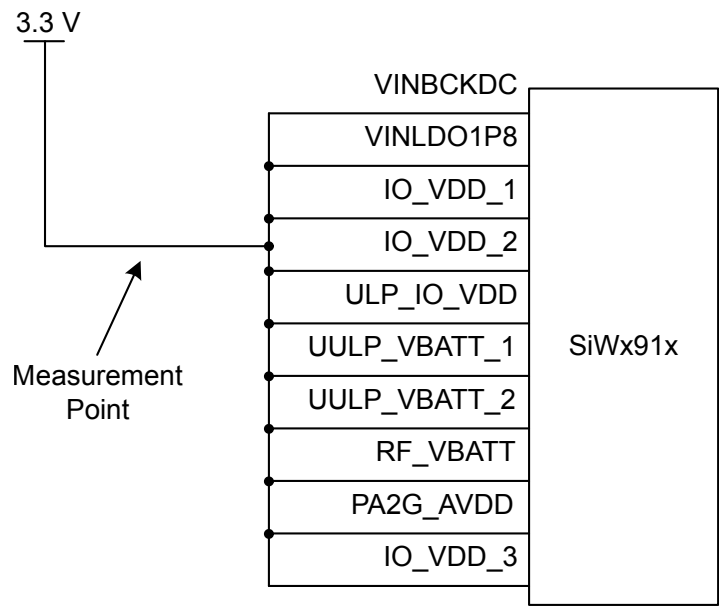

Figure 7.10. Supply Connection for Current Measurements

### 7.6.1 WLAN 2.4 GHz 3.3 V Current Consumption

T<sub>A</sub> = 25 °C. PA2G\_AVDD = VINBCKDC = 3.3 V. Remaining supplies are at typical operating conditions. NWP clock running at 80 MHz.

**Table 7.32. WLAN 2.4 GHz 3.3 V Current Consumption**

Parameter	Symbol	Test Condition	Min	Typ	Max	Unit
Listen current	I <sub>RX_LISTEN</sub>	LP Chain, 1 Mbps Listen	—	16.5	—	mA
Active Receive Current	I <sub>RX_ACTIVE</sub>	1 Mbps RX Active, LP Chain	—	22	—	mA
		HT20 MCS0, HP Chain	—	51	—	mA
		HT20 MCS7, HP Chain	—	51	—	mA
		HE20 MCS0, HP Chain	—	51	—	mA
		HE20 MCS7, HP Chain	—	51	—	mA
Transmit Current <sup>1</sup>	I <sub>TX</sub>	1 Mbps, HP Chain	—	240	—	mA
		HT20 MCS0, HP Chain	—	230	—	mA
		HT20 MCS7, HP Chain	—	180	—	mA
		HE20 MCS0, HP Chain	—	220	—	mA
		HE20 MCS7, HP Chain	—	170	—	mA
Deep Sleep	I <sub>SLEEP</sub>	No RAM retained	—	2.5	—	μA
		352 KB RAM retained	—	10	—	μA
Standby Associated, DTIM = 10	I <sub>STBY_ASSOC</sub>	WLAN Keep Alive Every 30 s with 352 KB RAM Retained, Without TCP Keep Alive	—	65	—	μA
		WLAN Keep Alive Every 30 s with 352 KB RAM Retained, TCP Keep Alive Every 240 s	—	67	—	μA
11ax TWT, Auto Config Enabled, Without TCP Keep Alive	I <sub>STBY_AX</sub>	RX latency 2 s with 8 ms wakeup duration, WLAN Keep Alive Every 30 s with 352 KB RAM Retained	—	92	—	μA
		RX latency 30 s with 8 ms wakeup duration, WLAN Keep Alive Every 30 s with 352 KB RAM Retained	—	32	—	μA
		RX latency 60 s with 8 ms wakeup duration, WLAN Keep Alive Every 60 s with 352 KB RAM Retained	—	22	—	μA
11ax TWT, Auto Config Enabled, With TCP Keep Alive Every 240 s	I <sub>STBY_AX_TCP</sub>	RX latency 2 s with 8 ms wakeup duration, WLAN Keep Alive Every 30 s with 352 KB RAM Retained	—	97	—	μA
		RX latency 30 s with 8 ms wakeup duration, WLAN Keep Alive Every 30 s with 352 KB RAM Retained	—	35	—	μA
		RX latency 60 s with 8 ms wakeup duration, WLAN Keep Alive Every 60 s with 352 KB RAM Retained	—	26	—	μA

**Note:**

1. The absolute maximum device current when transmitting at highest transmit power will not exceed 400 mA.

### 7.6.2 Bluetooth LE Current Consumption

T<sub>A</sub> = 25 °C. PA2G\_AVDD = VINBCKDC = 3.3 V. Remaining supplies are at typical operating conditions. NWP clock running at 80 MHz.

**Table 7.33. Bluetooth LE Current Consumption**

Parameter	Symbol	Test Condition	Min	Typ	Max	Unit
TX Active Current	I <sub>TX</sub>	LP chain, Tx Power = 0 dBm	—	10	—	mA
		LP chain, Tx Power = Max TX power	—	18	—	mA
RX Active Current	I <sub>RX</sub>	LP chain	—	11	—	mA
Advertising, Unconnectable	I <sub>ADV_UC</sub>	Advertising on all 3 channels, 37 Byte payload, Interval = 1.28 s, Tx Power = 0 dBm, LP chain	—	37	—	μA
Advertising, Connectable	I <sub>ADV_CN</sub>	Advertising on all 3 channels, 37 Byte payload, Interval = 1.28 s, Tx Power = 0 dBm, LP chain	—	41	—	μA
Connected	I <sub>CONN</sub>	Connection Interval = 1.28s, No data, Tx Power = 0 dBm, LP chain	—	41	—	μA
		Connection Interval = 200 ms, No data, Tx Power = 0 dBm, LP chain	—	125	—	μA



## 8.1.2 RF Supplies

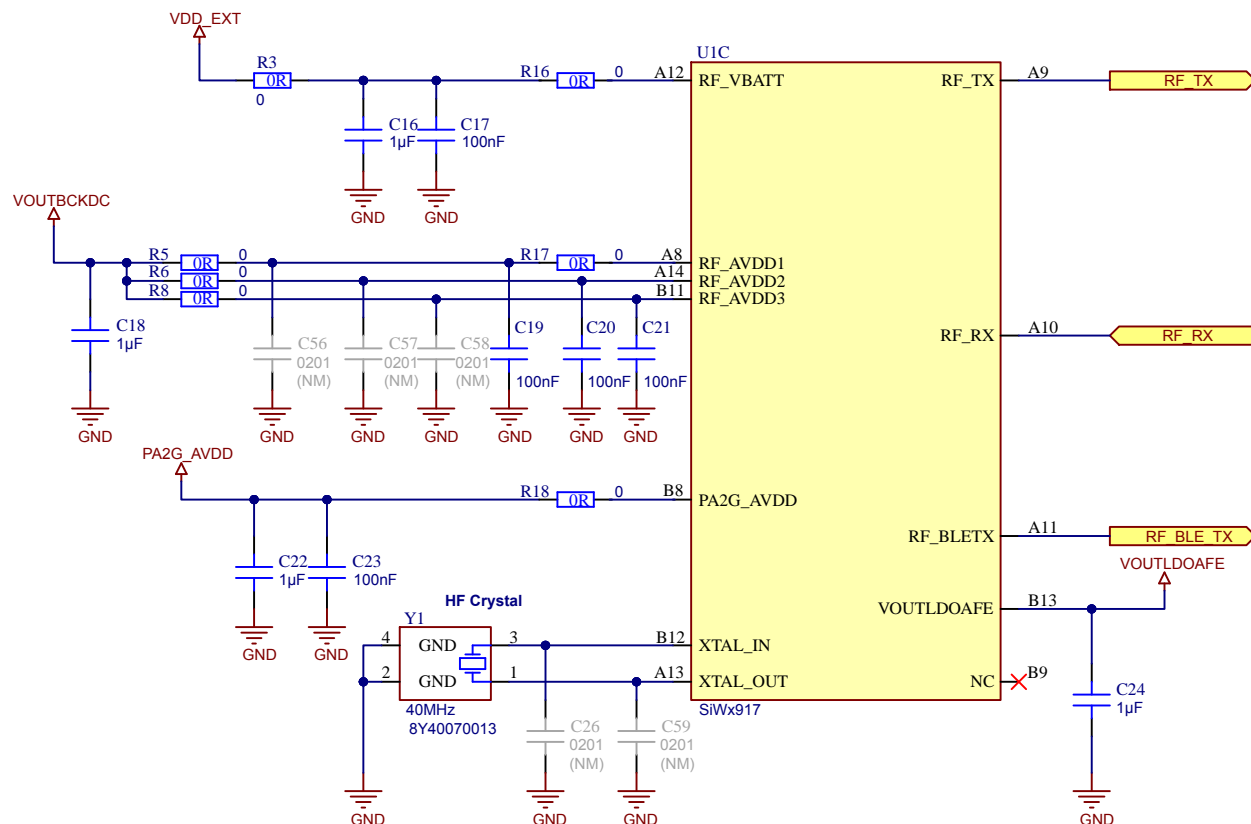

**Figure 8.2. RF Power and HF Crystal Support**

**Note:**

1. Do not share routing between PA2G\_AVDD and RF\_VBATT. Use star routing for PA2G\_AVDD and RF\_VBATT.
2. VOUTBCKDC should be star routed to RF\_AVDD supply pins.
3. VDD\_EXT supply voltage must match the recommended operating conditions of power supply pins.
4. Use recommended part for high frequency crystal 40 MHz. This 40 MHz crystal can be tuned with the internal capacitors in the device.
5. PA2G\_AVDD can be independent of other supplies and it must be operated at 3.3V only.
6. C26 and C59 are optional tuning capacitors.
7. R5, C56, R6, C57, R8 and C58 are placeholder components for power supply noise filtering.
8. R3 is a placeholder component for power supply noise filtering.
9. It is recommended to add test points to all supply pins.
10. R16, R17, R18 are placeholder components for 2.4 GHz Harmonics filtering. Place these close to the IC pins. If needed, these resistors should be replaced with inductors selected based on their self-resonance frequency being close to the harmonic(s) to be attenuated.
11. C24 component on VOUTLDOAFE must be mounted, either for Internal or External switch RF frontend design shown in [Section 8.1.4](#).

### 8.1.3 GPIO Supplies

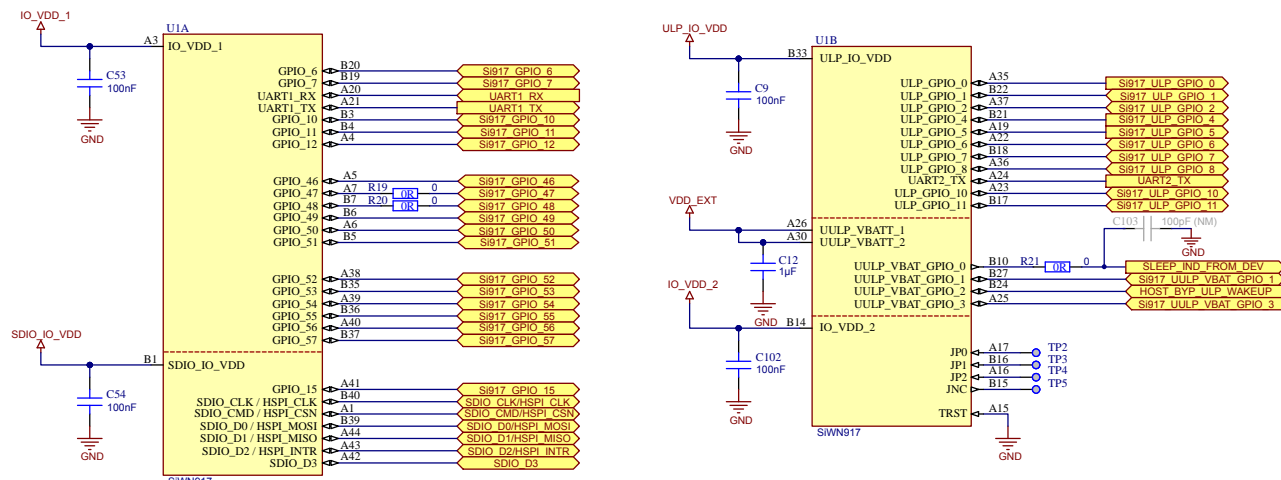

Figure 8.3. GPIO Supply Domains

**Note:**

1. IO\_VDD\_1, IO\_VDD\_2, IO\_VDD\_3, ULP\_IO\_VDD can be powered independently by different Voltage Sources based on their corresponding signals voltage levels requirements. Voltages must be as per the recommended Operating conditions
2. Place C12 close to UULP\_VBATT\_2 pin.
3. Even if GPIOs are not used, their respective IO domains must still be connected to the power supply.
4. VDD\_EXT supply voltage must match the recommended operating conditions of power supply pins.
5. It is recommended to add test points to all supply pins.
6. R19, R20, R21 are placeholder components for 2.4 GHz Harmonics filtering. Place these close to the IC pins. If needed, these resistors should be replaced with inductors selected based on their self-resonance frequency being close to the harmonic(s) to be attenuated.
7. C103 is placeholder component for improving Bluetooth Receiver sensitivity performance at 125 kbps data rate. Mount 100 pF capacitor, if required. Place it close to the resistor.
8. Some GPIOs can be configured in software, while others cannot be configured. For more information about configurable and non-configurable GPIOs, refer to the Pin descriptions and Notes in [Section 6.2.3](#).

### 8.1.4 RF Frontend

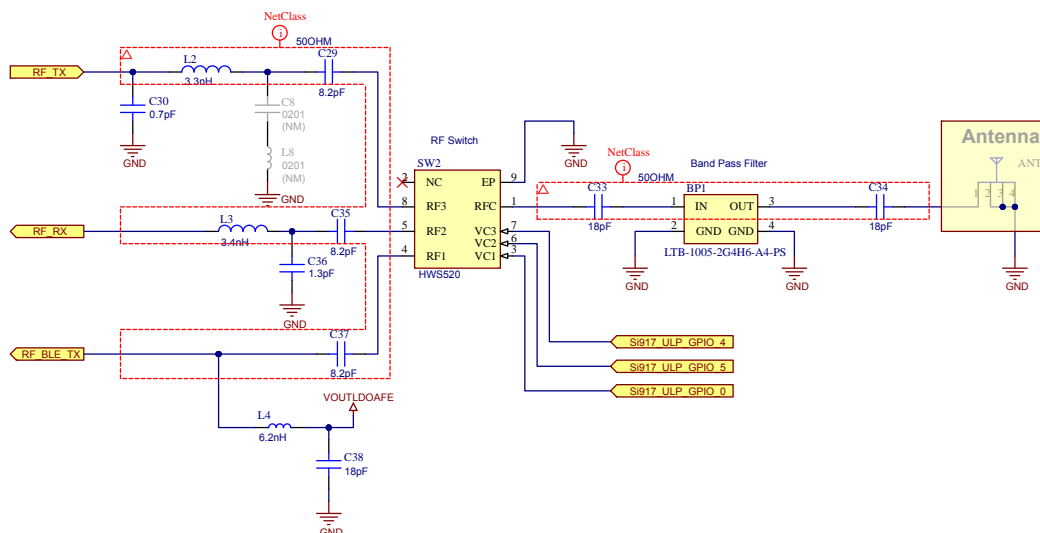

Figure 8.4. Option 1: RF Frontend with External Switch

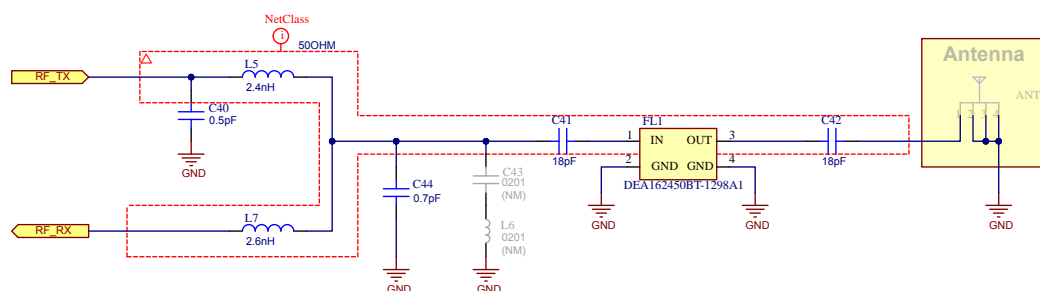

Figure 8.5. Option 2: RF Frontend with Internal Switch

**Note:**

1. ANT1 and ANT2: In-built antenna or an external antenna (with U.FL connector) can be used.
2. The 8 dBm BLE LP transmit path on RF\_BLE\_TX is not available for the internal switch option.
3. Maintain 50 ohm characteristic impedance for RF traces.
4. It is recommended to add microwave coaxial switch connector (Example : Murata's MM8430-2610RA1) or U.FL connector for conducted measurements.
5. Additional matching circuit to be provided near the antenna, based on antenna used and location on the board.
6. For the external RF switch option, follow the reference layout for RF front-end circuit from IC pins up to at least RF switch.
  - Provision C38 on the VOUTLDOAFE trace. C38 must be placed close to L4.
  - Trace routing from the VOUTLDOAFE pin to inductor L4 must be short, with a maximum length of 15 mm.
  - If the trace length is between 7.5 mm and 15 mm, mount capacitor C38.
7. For the internal RF switch option, follow the reference layout for RF front-end circuit from IC pins up to at least the FL1 band pass filter.
8. C8 and L8 (external switch) or C43 and L6 (internal switch) are placeholder components for harmonic emission filtering.
9. Follow guidelines in Application Note [AN1440](#) for calibrating the power of RF front-end circuitry.
10. Follow guidelines in Application Note [AN1423](#) for RF design related aspects.
11. There will be significant RF performance degradation if antenna select signals (ULP\_GPIO\_4, ULP\_GPIO\_5, ULP\_GPIO\_0) are powered at 1.8 V from the ULP\_IO\_VDD supply. It is recommended to supply ULP\_IO\_VDD from the 3.3 V supply.

12. There will be RF performance degradation with the internal RF switch option. Refer to Application Note [AN1423](#) for details.
13. ULP\_GPIO\_0/4/5 are used to control the switch in external switch configuration. These signals map to the following functions:
  - ULP\_GPIO\_0: RF\_BLETX pin active
  - ULP\_GPIO\_4: RF\_TX pin active
  - ULP\_GPIO\_5: RF\_RX pin active
14. Apart from the required RF Frontend components shown above in either [Figure 8.4](#) or [Figure 8.5](#), C24 is the mandatory component to be mounted on VOUTLDOAFE pin as shown in [Figure 8.2](#), either for Internal or External switch RF frontend design.
15. An RF shield is strongly recommended for designs using an internal RF switch configuration. For external RF switch-based designs, shielding should be provisioned and added as needed based on RF test results.

### 8.1.5 LF Clock Options

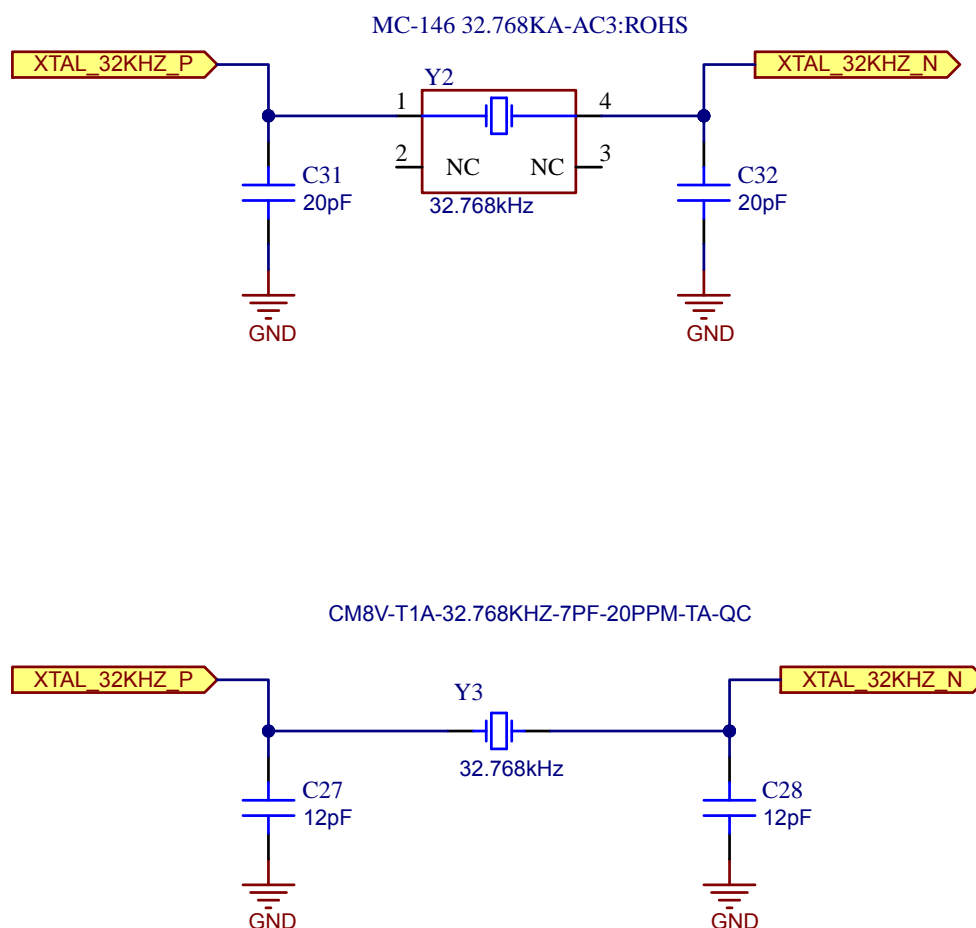

**Figure 8.6. 32.768 kHz Clock Options**

**Note:**

1. Two different crystals and their circuits are shown in the figure. Use one of them only.
2. Load capacitors for external crystals must be fine-tuned based on the layout design.

### 8.1.6 Flash Memory Configurations



Figure 8.7. Option 1: In-Package Flash Powered From On-Chip LDO Supply

### 8.1.7 Reset

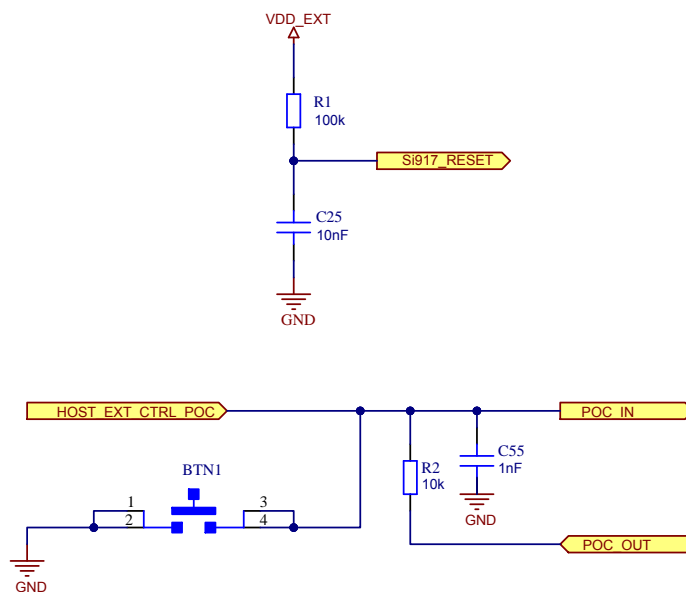

Figure 8.8. Reset Configuration

**Note:**

1. The configuration shown allows for blackout monitor functionality along with external reset of the SiWx917 IC.
2. The POC\_IN signal connects to the POC\_IN pin on the SiWx917. POC\_IN resets all the internal blocks of the IC.
3. The Si917\_RESET signal connects to the RESET\_N pin on the SiWx917. It is recommended to use the RC filter as shown. RESET\_N is an open-drain output pin that will be pulled low when POC\_IN goes low.
4. The POC\_OUT signal connects to the POC\_OUT pin on the SiWx917. POC\_OUT is an active-low, push-pull output from the internal blackout monitor. In this configuration, it is isolated from the external HOST\_EXT\_CTRL\_POC signal with a series resistor. In applications without external host control (HOST\_EXT\_CTRL\_POC), POC\_OUT may be directly connected to POC\_IN. Without external host control to the POC\_IN pin, the IC cannot be reset multiple times after power-on.
5. The HOST\_EXT\_CTRL\_POC signal connects to a GPIO of an external host processor. In this configuration, HOST\_EXT\_CTRL\_POC must be an open-drain output to allow POC\_OUT to control POC\_IN.
6. VDD\_EXT must be at the same voltage level as the UULP\_VBATT\_2 supply pin.
7. HOST\_EXT\_CTRL\_POC must be at the same voltage level as the UULP\_VBATT\_1 supply pin.

## 8.1.8 Host Interface

### Option 1: UART



### Option 2: HSPI

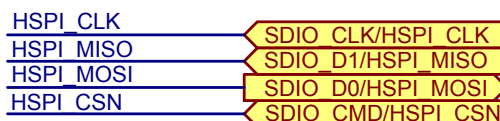

### Option 3: SDIO

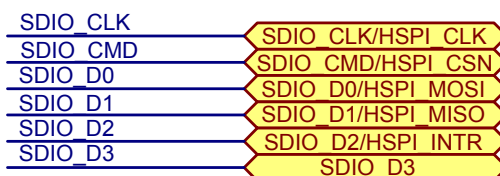

**Figure 8.9. Host Interface Options**

#### Note:

1. In UART mode, ensure that the input signals, UART\_RX and UART\_CTS are not floating when the device is powered up and reset is de-asserted. This can be done by ensuring that the host processor configures its signals (outputs) before de-asserting the reset.
2. In HSPI mode, ensure that the input signals, HSPI\_CSN and HSPI\_CLK are not floating when the device is powered up and reset is de-asserted. This can be done by ensuring that the external Host processor configures its signals (outputs) before de-asserting the reset. HSPI\_INTR is the interrupt signal driven by the secondary device. This signal may be configured as Active-high or Active-low. If it is active-high, an external pull-down resistor is required. If it is active-low, an external pull-up resistor is required.

The following actions can be carried out by the host processor during power-up of the device, and before/after ULP Sleep mode.

- a. To use the signal in the Active-high or Active-low mode, ensure that during the power up of the device, the Interrupt is disabled in the Host processor before de-asserting the reset. After de-asserting the reset, the Interrupt needs to be enabled only after the HSPI initialization is done and the Interrupt mode is programmed to either Active-high or Active-low mode as required.
  - b. The Host processor needs to disable the interrupt before the ULP Sleep mode is entered and enable it after HSPI interface is reinitialized upon wakeup from ULP Sleep.
3. In SDIO mode, pull-up resistors should be present on SDIO\_CMD & SDIO Data lines as per the SDIO physical layer specification version 2.0.

## 8.2 BOM

Manufacturer part numbers provided in this section are a guideline, and may be replaced with suitably equivalent components as needed. Device characteristics and performance are measured using the specified crystals, supply filtering, and RF frontend circuitry.

**Table 8.1. SiWN917 Circuitry: Mandatory Components (Power Management + Crystal + SiWN917 IC)**

S.No	Quantity	Designator	Value	Manufacturer	Manufacturer PN	Description
1	1	C1	10 $\mu$ F	Murata	GRM188R61C106MAALD	CAP CER 0603 X5R 10uF 16V 20%
2	10	C2, C5, C9, C10, C50, C51, C52, C53, C54, C102	100 nF	Murata	GRT155R71H104KE01D	CAP CER 0402 X7R 0.1uF 50V 10%
3	10	C3, C6, C7, C11, C12, C15, C16, C18, C22, C24	1 $\mu$ F	Murata	GRM033R61C105ME15D	CAP CER 0201 X5R 1uF 16V 20%
4	1	C4	10 $\mu$ F	CalChip	GMC21X7R106K25NT	CAP CER 0805 X7R 10uF 25V 10%
5	1	C13	2.2 $\mu$ F	Murata	GRM033R61A225ME47D	CAP CER 0201 X5R 2.2uF 10V 20%
6	1	C14	10 nF	Murata	GRM033R61C103KA12D	CAP CER 0201 X5R 10nF 16V 10%
7	5	C17, C19, C20, C21, C23	100 nF	Murata	GRM033R61C104KE14J	CAP CER 0201 X5R 100nF 16V 10%
8	1	L1	1 $\mu$ H	Murata	DFE201210U-1R0M=P2	IND Fixed 0805 1uH 2A 95mOhm 20%
9	10	R3, R5, R6, R8, R16, R17, R18, R19, R20, R21	0 $\Omega$	Yageo	RC0201FR-07200RL	RES 0201 0R
10	1	U1	SiWN917	Silicon Labs	SiWN917	Choose the suitable OPN from List of OPNs from Ordering Information section in data sheet.
11	1	Y1	40 MHz	TXC	8Y40070013	CRYSTAL 2.0X1.6mm 40MHz 8pF 8ppm

**Table 8.2. SiWN917: RF Front-End Options (one of them has to be used mandatorily)**

S. No.	Quantity	Designator	Value	Manufacturer	Manufacturer PN	Description
<b>Option 1: RF Matching +External RF Switch + Band Pass Filter</b>						
12	1	ANT1	2.45 GHz	Johanson	2450AT18D0100001	ANT SMD 3.2X1.6X1.2MM 2.4GHz
13	1	BP1	2.45 GHz	Maglayers	LTB-1005-2G4H6-A4-PS	FILTER BAND PASS 0402-4Pin 2.45GHz 100MHz
14	3	C29, C35, C37	8.2 pF	Murata	GJM0335C1E8R2BB01	CAP CER 0201 C0G 8.2pF 25V $\pm$ 0.1pF

S. No.	Quantity	Designator	Value	Manufacturer	Manufacturer PN	Description
15	1	C30	0.7 pF	Murata	GJM0335C1HR70WB01	CAP CER 0201 C0G 0.7pF 50V ±0.05pF
16	2	C33, C34, C38	18 pF	Murata	GRM0335C1H180GA01	CAP CER 0201 C0G 18pF 50V 2%
17	1	C36	1.3 pF	Murata	GJM0335C1E1R3WA01D	CAP CER 0201 C0G 1.3pF 50V ±0.05pF
18	1	L2	3.3 nH	Murata	LQP03HQ3N3B02	IND Fixed 0201 3.3nH 500mA 170mOhm ±0.1nH
19	1	L3	3.4 nH	Murata	LQP03TN3N4C02	IND Fixed 0201 3.4nH 450mA 250mOhm ±0.2nH
20	1	L4	6.2 nH	Murata	LQP03HQ6N2H02	IND Fixed 0201 6.2nH 400mA 250mOhm 3%
21	1	SW2	HWS520	Hexawave	HWS520	IC RF SWITCH SP3T 6GHz USON8L
<b>Option 2: Internal RF Switch + Matching + BPF</b>						
22	1	ANT2	2.45 GHz	Johanson	2450AT18D0100001	ANT SMD 3.2X1.6X1.2MM 2.4GHz
23	2	C41, C42	18 pF	Murata	GJM0335C1E180GB01D	CAP CER 0201 C0G 18pF 25V 2%
24	1	C40	0.5 pF	Murata	GJM0335C1ER50WB01	CAP CER 0201 C0G 0.5pF 25V ±0.05pF
25	1	C44	0.7 pF	Murata	GJM0335C1ER70WB01	CAP CER 0201 C0G 0.7pF 25V ±0.05pF
26	1	FL1	2.45 GHz	TDK	DEA162450BT-1298A1	FILTER BAND PASS 1608 2400MHz 2500MHz
27	1	L5	2.4 nH	Murata	LQP03TN2N4B02	IND Fixed 0201 2.4nH 500mA 200mOhm ±0.1nH
28	1	L7	2.6 nH	Murata	LQP03TN2N6B02	IND Fixed 0201 2.6nH 500mA 200mOhm ±0.1nH

**Table 8.3. SiWN917: External 32.768 kHz Clock Options**

S. No.	Quantity	Designator	Value	Manufacturer	Manufacturer PN	Description
<b>Option 1a: 32.768 kHz Crystal</b>						
29	1	Y2	32.768 kHz	Epson	MC-146 32.768KA-AC3:ROHS	CRYSTAL 7.0x1.5mm 32.768kHz 9pF 20ppm
30	2	C31, C32	20 pF	Murata	GRM0335C1H200GA01	CAP CER 0201 C0G 20pF 50V 2%
<b>Option 1b: 32.768 kHz Crystal</b>						
31	2	C27, C28	12 pF	Murata	GRM0335C1H120FA01	CAP CER 0201 C0G 12 pF, 50V, 1%
32	1	Y3	32.768 kHz	Micro Crystal	CM8V-T1A-32.768KHZ-7PF-20PPM-TA-QC	CRYSTAL 2.0x1.2mm 32.768kHz 7pF 20ppm

**Table 8.4. SiWN917: Discrete Parts (BTN1 is optional and need not be used for every use-case)**

S. No.	Quantity	Designator	Value	Manufacturer	Manufacturer PN	Description
33	1	BTN1	PTS810 SJM 250 SMTR LFS	C&K	PTS810 SJM 250 SMTR LFS	Tactile Switch SPST-NO 0.05A 16V
34	1	R1	100 kΩ	Yageo	RC0201FR-07100KL	RES 0201 100K 1/20W 1% 200ppm
35	1	C25	10 nF	Murata	GRM033R61C103KA12D	CAP CER 0201 X5R 10nF 16V 10%
36	1	R2	10 kΩ	Yageo	RC0201FR-0710KL	RES 0201 10K 1/20W 1% 200ppm
37	1	C55	1 nF	Murata	GRM033R71C102KA01D	CAP CER 0201 X7R 1nF 16V 10%

### 8.3 Layout Guidelines for DR-QFN

The following guidelines outline the integration of the DR-QFN:

1. The following supply pins must be star routed from the supply source:
  - a. VINBCKDC
  - b. VINLDO1P8
  - c. IO\_VDD\_1, IO\_VDD\_2, IO\_VDD\_3
  - d. ULP\_IO\_VDD
  - e. UULP\_VBATT\_1
  - f. UULP\_VBATT\_2
  - g. RF\_VBATT
  - h. PA2G\_AVDD
2. The RF traces must have a characteristic impedance of 50 Ohms. Any standard 50 Ohms RF trace (Microstrip or Coplanar wave guide) may be used. The width of the 50 Ohms line depends on the PCB stack, e.g., the dielectric of the PCB, thickness of the copper, thickness of the dielectric and other factors. Consult the PCB fabrication unit to get these factors right.
3. Each GND pin must have a separate GND via.
4. All decoupling capacitors placement must be as much close as possible to the corresponding power pins, and the trace lengths as short as possible.
5. Ensure all power supply traces widths are sufficient enough to carry corresponding currents.
6. Add GND copper pour underneath IC in all layers, for better thermal dissipation.
7. Provision an RF shield around the IC and RF circuitry, excluding antenna portion. RF shield requirements depend on the matching circuit type, refer to section [8.1.4 RF Frontend](#) for the details.
8. Refer to RF Matching and Layout Design Guide Application Note [AN1423](#) for more details about following RF related design aspects.
9. Add 5 x 5 thermal vias (25 total) of at least 10-mils drill size equally placed on the "GND paddle" for better thermal dissipation.
10. The layout guidelines for the buck DC-DC are as follows:

Minimize the loop area formed by inductor switching node, output capacitors & input capacitors. This helps keep high current paths as short as possible. Keeping high current paths shorter and wider would help decrease trace inductance & resistance. This would significantly help increase the efficiency in high current applications. This reduced loop area would also help in reducing the radiated EMI that may affect nearby components.

  - a. The capacitor for VINBCKDC (C1) should be very close to the IC pin and the ground pad of the capacitor should have direct vias to the ground plane.
  - b. The inductor (L1) should be close to IC pin VOUTBCKDC and the buck capacitor (C4) should be placed close to the inductor. The ground pad of the capacitor should have direct vias to the ground plane underneath.
  - c. The ground plane underneath the buck inductor (L1) in the top layer should be made as an isolated copper patch and should descend down to the main ground layer through multiple vias.
  - d. The path from VOUTBCKDC to VINLDOSOC is a high current path. The trace should be as short and wide as possible and it is recommended to run grounded shield traces on either side of this high current trace.
  - e. The capacitor on VINLDOSOC (C4) should be very close to the IC pin & the ground pad of the capacitor should have direct vias to the ground plane underneath.
11. Refer to Silicon Labs' radio board designs and Application Note [AN1423](#) for layout examples.

## 8.4 Calibration Requirements

The IC design circuit, as shown in Section [8.1 Schematics](#), involves discrete components in the RF path and 50-ohm PCB traces. There can be variations in manufacturing tolerances from these discrete components and part-to-part IC variation leading to board-to-board performance variation in power level.

Accurate control over TX power is required for regulatory purposes. It is recommended that one performs TX Gain offset calibration on the end-product to compensate for these board-to-board power variations. This requires provision for conducted power measurement on end-product. If the customer does not have the capability for conducted power measurement and this calibration, then fixed TX power back off may be required to ensure regulatory compliance.

Refer to the following Application Notes for detailed calibration procedures:

- Application Note [AN1436](#) for calibrating the external 40 MHz crystal.
- Application Note [AN1440](#) for calibrating the power of RF front-end circuitry.

## 9. Package Specifications

### 9.1 Package Outline

**Table 9.1. Package Dimensions - DR-QFN**

Parameter	Value (LxWxH)	Units
Package Dimensions	7 x 7 x 0.85	mm
Tolerance	±0.1	mm

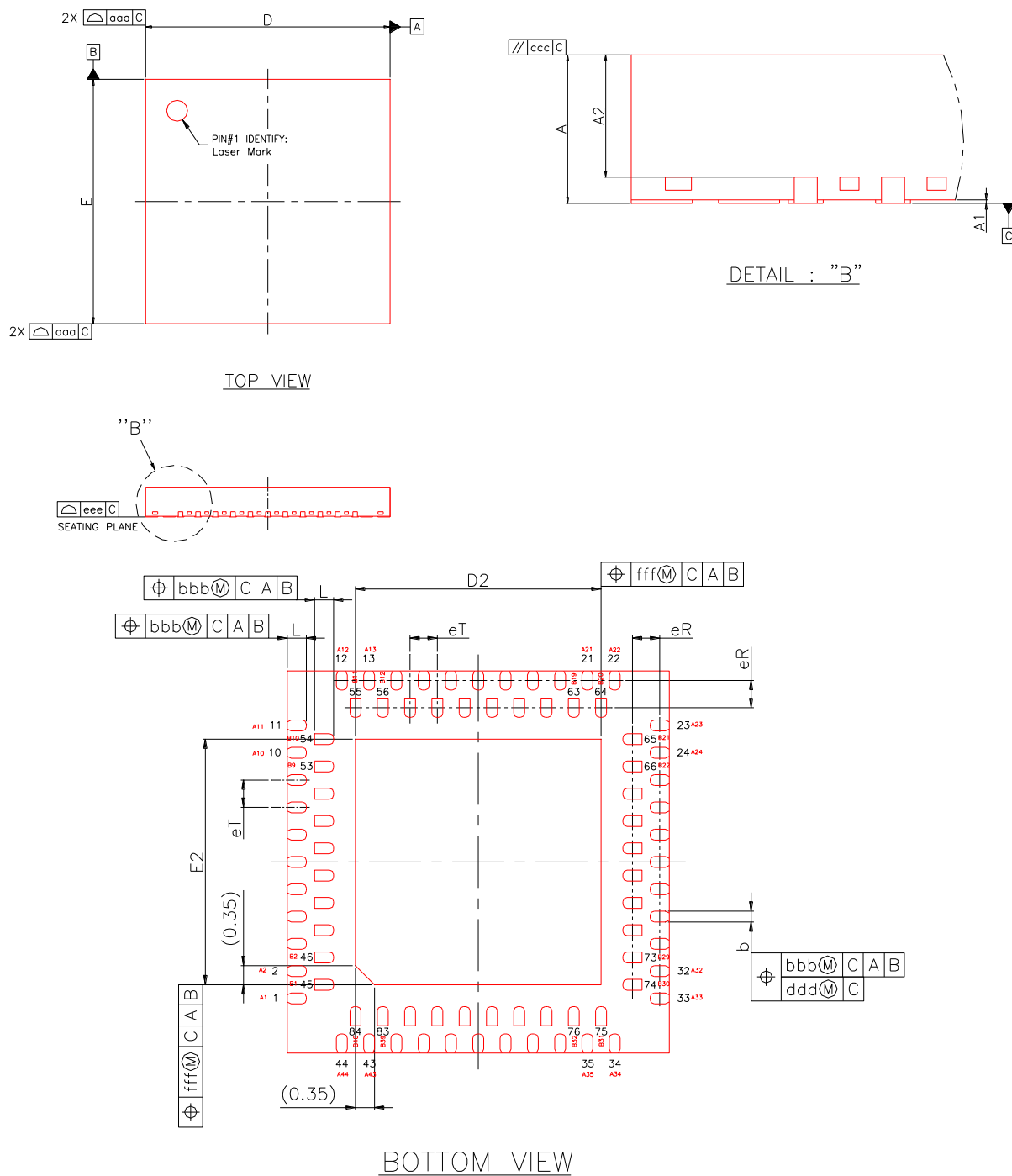

Figure 9.1. Package Outline - DR-QFN

**Table 9.2. PCB Landing Pattern - DR-QFN**

Dimension	MIN	NOM	MAX
A	0.75	0.85	0.95
A1	0.00	0.02	0.05
A2	0.65	0.70	0.75
b	0.15	0.20	0.25
D	6.90	7.00	7.10
E	6.90	7.00	7.10
D2	4.40	4.50	4.60
E2	4.40	4.50	4.60
eT	0.50 BSC		
eR	0.50 BSC		
L	0.30	0.35	0.40
aaa	0.10		
bbb	0.10		
ccc	0.20		
ddd	0.05		
eee	0.08		
fff	0.10		

**Note:**

1. All dimensions shown are in millimeters (mm) unless otherwise noted.
2. Dimensioning and Tolerancing per ANSI Y14.5M-1994.
3. This drawing conforms to the JEDEC Solid State Outline MO-220.
4. Recommended card reflow profile is per the JEDEC/IPC J-STD-020 specification for Small Body Components.

## 9.2 PCB Land Pattern

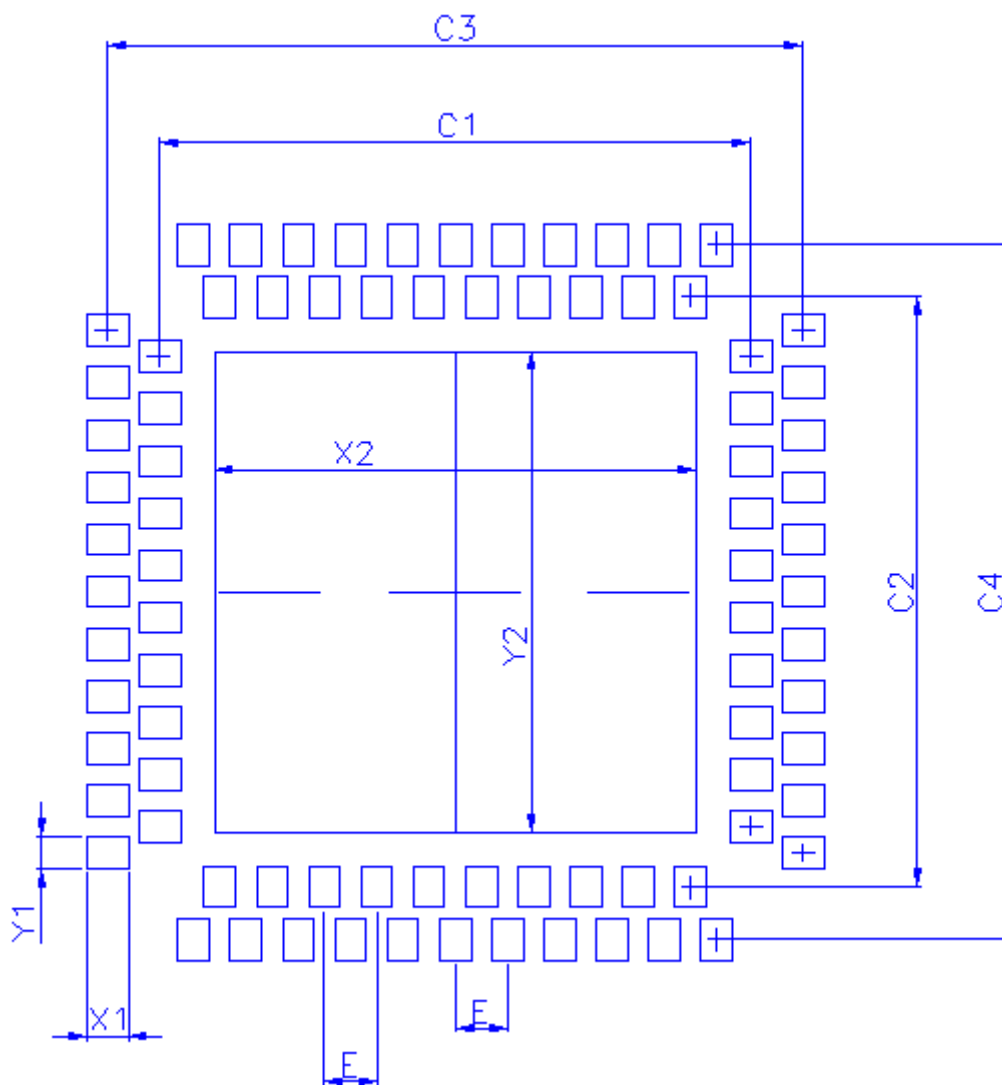

Figure 9.2. PCB Landing Pattern - DR-QFN

**Table 9.3. Dimension Table**

Dimension	mm
C1	5.65
C2	5.65
C3	6.65
C4	6.65
E	0.5 BSC
X1	0.40
X2	4.60
Y1	0.25
Y2	4.60

**Note:**

**General**

1. All feature sizes shown are at Maximum Material Condition (MMC) and a card fabrication tolerance of 0.05 mm is assumed.
2. Dimensioning and Tolerancing is per the ANSI Y14.5M-1994 specification.

**Solder Mask Design**

1. All pads are to be non-solder mask defined (NSMD). Clearance between the solder mask and the metal pad is to be 10 µm minimum, all the way around the pad.

**Stencil Design**

1. A stainless steel, laser-cut and electro-polished stencil with trapezoidal walls should be used to assure good solder paste release.
2. The stencil thickness should be 0.100 mm (4 mils).
3. The stencil aperture to land pad size recommendation is 80% paste coverage.

\*Above notes and stencil design are shared as recommendations only. A customer or user may find it necessary to use different parameters and fine tune their SMT process as required for their application and tooling.

### 9.3 Top Marking

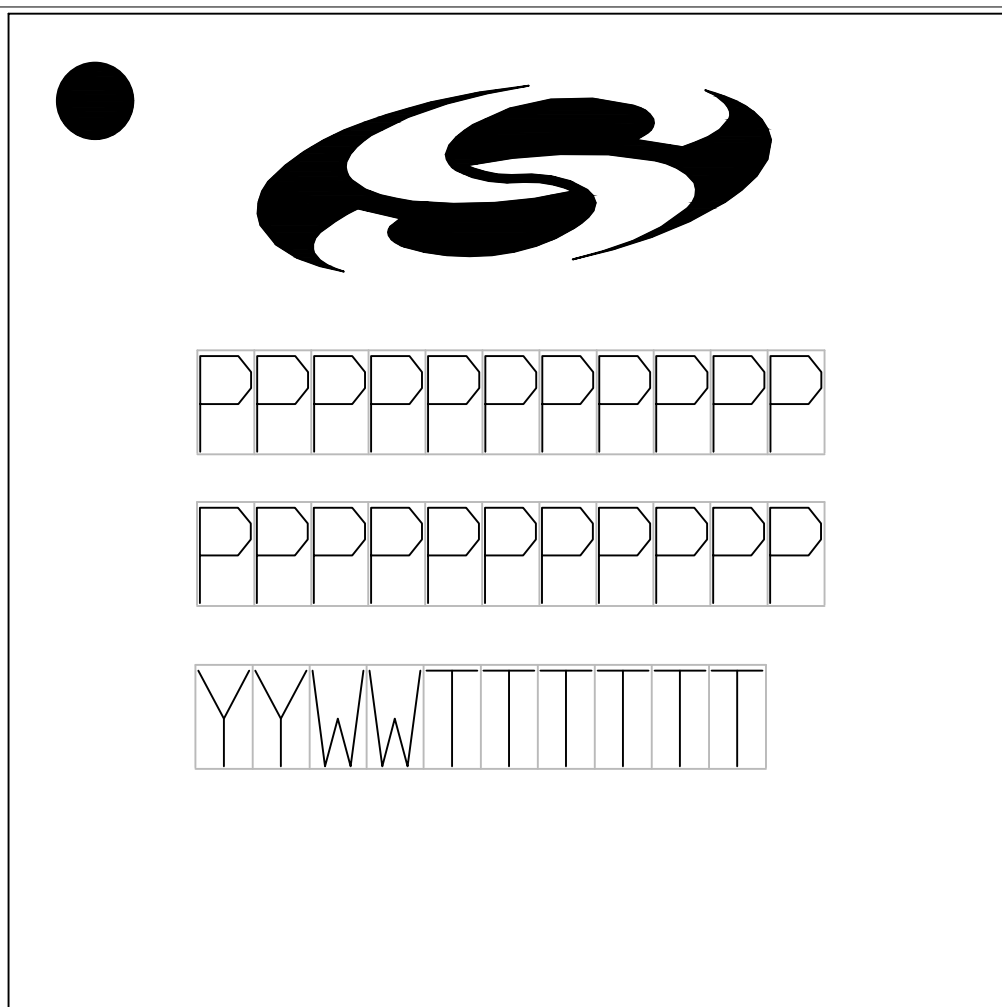

**Figure 9.3. Top Marking**

#### Mark Description

The package marking consists of:

- P P P P P P P P P P - Part number designation in both the rows
- Y Y W W T T T T T T
  - Y Y – Last two digits of the assembly year
  - W W – Two-digit workweek when the device was assembled
  - T T T T T T – A trace or manufacturing code. The first letter is the device revision.

## 10. SiWN917 Documentation and Support

Silicon Labs offers a set of documents which provide further information required for evaluating, and developing products and applications using SiWN917. These documents will be available on the Silicon Labs website. The documents include information related to Software releases, Evaluation Kits, User Guides, Programming Reference Manuals, Application Notes, and others.

For further assistance, you can contact Silicon Labs Technical Support [here](#).

### Resource Location

SiWN917 Document Library: <https://docs.silabs.com/wisecconnect/latest/wisecconnect-developing-with-wisecconnect-sdk/>

Technical Support: <http://www.silabs.com/support/>

## 11. Revision History

### Revision 1.2

February, 2026

- Replaced MU-MIMO/OFDMA with DL MU-MIMO, DL/UL OFDMA in Key Features section.
- Following are the updates in [1. Feature List](#).
  - Updated Software and Regulatory Certifications: Regulatory pre-certifications (FCC, IC, RED, UKCA, MIC) to Verified for compliance with FCC, ISED, CE, UKCA, MIC regulatory requirements.
  - Updated Note section.
- Following are the updates in [5.3 Bluetooth](#):
  - Updated Transmit power up to +19.5 dBm to Transmit power up to +19 dBm.
- Updated UART in [5.5 Host Interfaces](#)
- Added Note section in [6.1 Pin Diagram](#)
- Updated [Table 6.3. Chip Packages - Peripheral Interfaces](#): Replaced HighZ default state with High for GPIO\_30/SDIO\_D3 pin; Added test points notes for debug pins.
- Following are the updates in [7. Electrical Specifications](#)
  - Updated [7.1 Absolute Maximum Ratings](#)
  - Updated [7.2 Recommended Operating Conditions](#)
  - Added Note section in [7.4.1.2 40 MHz Clock](#)
  - Updated [Table 7.22. WLAN 2.4 GHz Transmitter Characteristics with 3.3 V Supply](#)
  - Updated [Table 7.23. WLAN 2.4 GHz Receiver Characteristics on HP RF Chain](#)
  - Updated [Table 7.24. WLAN 2.4 GHz Receiver Characteristics on LP RF Chain](#)
  - Updated [Table 7.25. Bluetooth Transmitter Characteristics on High-Performance \(HP\) RF Chain](#)
  - Updated [Table 7.26. Bluetooth Transmitter Characteristics on Low-Power \(LP\) 8 dBm RF Chain](#)
  - Updated [Table 7.27. Bluetooth Transmitter Characteristics on Low-Power \(LP\) 0 dBm RF Chain](#)
  - Updated Note section in [Table 7.28. Bluetooth Receiver Characteristics for 1 Mbps Data Rate](#)
  - Updated Note section in [Table 7.29. Bluetooth Receiver Characteristics for 2 Mbps Data Rate](#)
  - Updated Note section in [Table 7.30. Bluetooth Receiver Characteristics for 125 kbps Data Rate](#)
  - Updated Note section in [Table 7.31. Bluetooth Receiver Characteristics for 500 kbps Data Rate](#)
  - Updated [Table 7.33. Bluetooth LE Current Consumption](#):
    - Typical current consumption for the 1.28s connected interval parameter by changing the value from 36  $\mu$ A to 41  $\mu$ A.
    - Typical current consumption for the 200 ms connected interval parameter by changing the value from 115  $\mu$ A to 125  $\mu$ A.
- Updated Note section in [8.1.2 RF Supplies](#)
- Updated Note section in [8.1.3 GPIO Supplies](#)
- Updated Note section in [8.1.4 RF Frontend](#)
- Updated C27, C28 parts information in [Table 8.3. SiWN917: External 32.768 kHz Clock Options](#)
- Removed C103 part information from [Table 8.4. SiWN917: Discrete Parts \(BTN1 is optional and need not be used for every use-case\)](#)
- Updated Point 7 in [8.3 Layout Guidelines for DR-QFN](#)
- Resource Location Link Updated: <https://docs.silabs.com/wisconnect/latest/wisconnect-developing-with-wisconnect-sdk/>

### Revision 1.1

September, 2025

- Added Host Interface peripherals information in [1. Feature List](#).
- Added [5.5 Host Interfaces](#).
- Updated RF\_RX pin description information in [6.2.1 RF and Control Interfaces](#).
- Added [7.4.4 UART](#).
- Updated Notes in [7.5.4 Bluetooth Transmitter Characteristics on High-Performance \(HP\) RF Chain](#), [7.5.5 Bluetooth Transmitter Characteristics on Low-Power \(LP\) 8 dBm RF Chain](#), [7.5.6 Bluetooth Transmitter Characteristics on Low-Power \(LP\) 0 dBm RF Chain](#).
- Added R16, R17, R18 in section [8.1.2 RF Supplies](#) and [8.2 BOM](#).
- Added R19, R20, R21, C103 in [8.1.3 GPIO Supplies](#) and [8.2 BOM](#).

**Revision 1.0**

December, 2024

- Removed LVCMOS external 32.768 kHz clock option. A 32.768 kHz crystal is mandatory for all applications requiring low-power Wi-Fi, BLE, and Coex sleep.
- Updated language used for security features throughout document
- [6.1 Pin Diagram](#): Corrected name of UULP\_VOUTSCDC pin
- [7. Electrical Specifications](#):
  - [Table 7.7. Flash LDO Electrical Specifications - Regulation Mode](#): Load regulation maximum changed to 3%
  - Removed specification table for internal RC boot oscillator and clarified this is only for boot-up
  - All electrical specifications updated with final char results and test limits
- [8. Reference Schematics, BOM and Layout Guidelines](#)
  - Updated schematic images with text-searchable versions
  - Corrected manufacturer part details for C36, L2, L3, C41, C42, C40, C44, L5, and L7
  - Added notes for position and usage of capacitor C38

**Revision 0.7**

September, 2024

- Replaced references to "ThreadArch" with "Network Wireless Processor" and / or "NWP"
- [Table 2.2. List of OPNs](#): Removed OPN SIWN917M100XGTBA
- Removed references to external flash support
- Corrected last character of OPN decoder, which is Reserved for these products
- Normalized pin names for SPI Secondary to HSPI Secondary to match documentation and software
- Corrected package name to DR-QFN throughout document
- Removed non-implemented peripherals from block diagrams, text, and specification tables
- Updated typical electrical characteristics with characterization results
- [7.1 Absolute Maximum Ratings](#): Added absolute maximum voltage and current ratings for I/O pins
- [7.3.2 Power On Control \(POC\) and Reset](#) Clarified POC and Reset functionality
- [7.5 RF Characteristics](#) Added supported WLAN channels for different regions
- [8. Reference Schematics, BOM and Layout Guidelines](#)
  - Split schematics into separate figures with in-text notes for legibility
  - Updated component recommendations per final design guidelines
- [Figure 9.2. PCB Landing Pattern - DR-QFN](#): Corrected dimensions C1, C2, C3, C4
- Presentation and formatting changes throughout document, including figure and table title assignments, units, cross-references, specification table formats, GPIO mux table formats, etc.

**Revision 0.5**

December, 2023

- Updated [Section 2. Ordering Information](#)
- Updated [Table 6.3. Chip Packages - Peripheral Interfaces](#)
- Updated [7.3.3.1 SC-DCDC](#)
- Updated [Section 7.6.1 WLAN 2.4 GHz 3.3 V Current Consumption](#)

**Revision 0.1**

October, 2023

Initial draft.

# The Leading Innovator in Low-Power Wireless.



## IoT Portfolio

[silabs.com/products](https://silabs.com/products)



## Simplicity Studio

[silabs.com/simplicity](https://silabs.com/simplicity)



## Quality

[silabs.com/quality](https://silabs.com/quality)



## Support & Community

[silabs.com/community](https://silabs.com/community)

### Disclaimer

Silicon Labs provides customers with data sheets, application notes and product briefs (“Product Documentation”) that are intended to present current, accurate and in-depth information about Silicon Labs’ integrated circuits, peripherals, modules and other products (“Products”). Silicon Labs may also provide reference designs, schematics, design files, software, tools, documentation, consultation and other customer support materials (“Support Materials”) that are intended solely to assist customers in developing their own modules, boards or other applications or products that include one or more Silicon Labs Products and may not be used for any other purposes.

Characterization data, device specifications, memory sizes, memory addresses and typical parameters can and do vary in different applications and are provided for illustrative purposes only, are subject to change without notice, and should not be relied upon without independent verification. Product firmware may be updated during the manufacturing process for security or reliability purposes.

Product Documentation does not imply or expressly grant any license to design or fabricate integrated circuits or modules. Customers are solely responsible for the design and distribution of their products including the acquisition of licenses to any necessary intellectual property rights.

Product Documentation and Support Materials are not authorized for use in or in connection with FDA Class III devices or military, automotive or aviation applications and shall in no circumstances be used in weapons of mass destruction or systems capable of delivering such weapons.

SILICON LABS DOES NOT WARRANT THAT PRODUCT DOCUMENTATION OR SUPPORT MATERIALS WILL MEET YOUR REQUIREMENT OR THAT THEIR OPERATION WILL BE UNINTERRUPTED OR THAT ANY SOFTWARE WILL BE ERROR-FREE. PRODUCT DOCUMENTATION AND SUPPORT MATERIALS ARE PROVIDED “AS IS” AND “WITH ALL FAULTS.” SILICON LABS MAKES NO REPRESENTATIONS OR WARRANTIES OF ANY KIND, EXPRESS OR IMPLIED, REGARDING THE ACCURACY, COMPLETENESS, RELIABILITY, OR SUITABILITY OF PRODUCT DOCUMENTATION OR SUPPORT MATERIALS, INCLUDING BUT NOT LIMITED TO WARRANTIES OF MERCHANTABILITY, FITNESS FOR A PARTICULAR PURPOSE, OR NON-INFRINGEMENT. SILICON LABS DISCLAIMS ALL IMPLIED WARRANTIES.

### Trademark Notice

Silicon Laboratories®, Silicon Labs®, Silabs®, and the Silicon Labs S-logo as well as other product or service names used herein are trademarks or registered trademarks of Silicon Laboratories Inc. For more information, please visit: [Silicon Labs Trademark Use Guidelines - Silicon Labs](#). Arm®, Cortex® and Keil® are trademarks or registered trademarks of Arm Holdings or Arm Limited. All other third-party products or brand names mentioned herein are trademarks of their respective holders.