



# Pentium® II Processor – Low-Power Module

Datasheet

## Product Features

- Pentium® II Processor – Low Power running at 266 MHz
- Second-level cache of pipeline burst SRAM
  - Dedicated 64-bit wide bus for high speed data transfer
  - 512 Kbyte cache data array
  - Clock to BSRAM turns off when processor is in low-power states
- Processor core voltage regulation supports input voltages from 5 V to 21 V
  - Above 80 percent peak efficiency
- Active Thermal Feedback (ATF) sensing
  - Internal A/D - digital signaling (SMBUS) across the module interface
  - Programmable trip point interrupt or poll mode for temperature reading
- Thermal transfer plate for heat dissipation
- Intel 443BX Host Bridge/Controller
  - DRAM controller supports EDO and SDRAM at 3.3 V
  - Supports PCI CLKRUN# protocol
  - SDRAM clock enable support and self refresh of EDO or SDRAM during Suspend mode
  - Compatible SMRAM (C\_SMRAM) and Extended SMRAM (E\_SMRAM) modes of power management; E\_SMRAM mode supports write-back cacheable SMRAM up to 1 Mbyte
  - 3.3 V PCI bus control, Rev 2.1 compliant
- Support single AGP-66 3.3 V device

The Low-Power Module is a small, highly integrated assembly containing an Intel Pentium® II Processor – Low-Power and its immediate system-level support. The processor module contains a power supply for the processor's unique voltage requirements, a system Level 2 cache memory, and the core logic required to bridge the processor to standard system buses. The module interfaces electrically to its host system via a 3.3-V PCI bus, a 3.3-V memory bus and some control signals for the Intel 443BX Host Bridge/Controller.

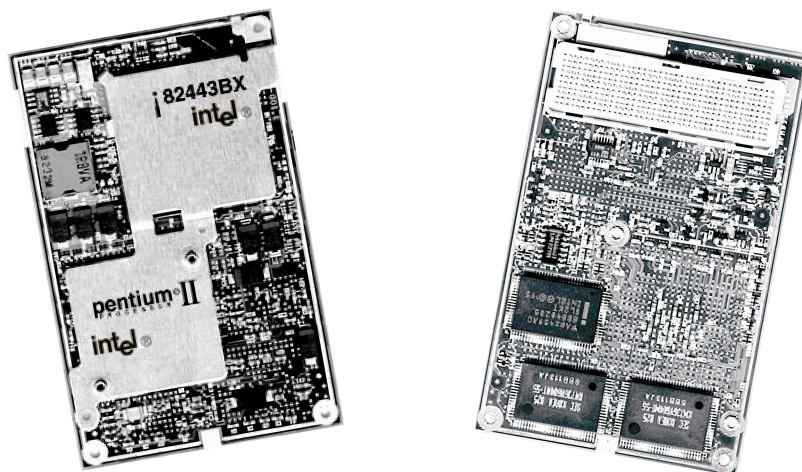

Order Number: 273256-002  
February 2000



Information in this document is provided in connection with Intel® products. No license, express or implied, by estoppel or otherwise, to any intellectual property rights is granted by this document. Except as provided in Intel's Terms and Conditions of Sale for such products, Intel assumes no liability whatsoever, and Intel disclaims any express or implied warranty, relating to sale and/or use of Intel products including liability or warranties relating to fitness for a particular purpose, merchantability, or infringement of any patent, copyright or other intellectual property right. Intel products are not intended for use in medical, life saving, or life sustaining applications.

Intel may make changes to specifications and product descriptions at any time, without notice.

Designers must not rely on the absence or characteristics of any features or instructions marked "reserved" or "undefined." Intel reserves these for future definition and shall have no responsibility whatsoever for conflicts or incompatibilities arising from future changes to them.

The Pentium® II processor may contain design defects or errors known as errata which may cause the product to deviate from published specifications. Current characterized errata are available on request.

MPEG is an international standard for video compression/decompression promoted by ISO. Implementations of MPEG CODECs, or MPEG enabled platforms may require licenses from various entities, including Intel Corporation.

Contact your local Intel sales office or your distributor to obtain the latest specifications and before placing your product order.

Copies of documents which have an ordering number and are referenced in this document, or other Intel literature may be obtained by calling 1-800-548-4725 or by visiting Intel's website at <http://www.intel.com>.

Copyright © Intel Corporation, 2000

\*Third-party brands and names are the property of their respective owners.

# Contents

---

<b>1.0</b>	<b>Introduction</b> .....	7
1.1	Module Terminology .....	7
<b>2.0</b>	<b>Architecture Overview</b> .....	7
<b>3.0</b>	<b>Module Connector Interface</b> .....	10
3.1	Signal Definitions.....	10
3.1.1	Signal List.....	10
3.1.2	Memory (109 Signals) .....	11
3.1.3	AGP (60 SIGNALS).....	12
3.1.4	PCI (58 SIGNALS) .....	13
3.1.5	Processor/PIIX4E Sideband (8 Signals).....	14
3.1.6	Power Management (7 Signals) .....	15
3.1.7	Clock (9 Signals) .....	16
3.1.8	Voltages (54 Signals) .....	17
3.1.9	ITP/JTAG (9 Signals) .....	17
3.1.10	Miscellaneous (82 Signals) .....	18
3.2	Connector Pin Assignments .....	18
3.3	Pin and Pad Assignments .....	20
<b>4.0</b>	<b>Functional Description</b> .....	22
4.1	Low-Power Module.....	22
4.2	L2 Cache .....	22
4.3	443BX Host Bridge/Controller .....	22
4.3.1	Memory Organization .....	23
4.3.2	Reset Strap Options .....	23
4.3.3	PCI Interface .....	24
4.3.4	AGP Interface .....	24
4.4	Electrical Requirements .....	25
4.4.1	DC Requirements .....	25
4.4.2	AC Requirements .....	26
4.4.2.1	System Bus Clock (BCLK) Signal Quality Specifications and Measurement Guidelines .....	27
4.5	Module Signal Termination.....	28
4.6	Processor Core Voltage Regulation .....	28
4.6.1	Voltage Regulator Efficiency .....	28
4.6.2	Voltage Regulator Control .....	29
4.6.2.1	Voltage Signal Definition and Sequencing .....	29
4.6.3	Power Planes: Bulk Capacitance Requirements .....	31
4.6.3.1	V <sub>DC</sub> and V <sub>5</sub> Decoupling .....	32
4.6.4	Surge Current Study.....	32
4.6.4.1	Slew-Rate Control: Circuit Description .....	34
4.6.4.2	Under-Voltage Lockout: Circuit Description .....	36
4.6.4.3	Over Voltage Lockout: Circuit Description.....	36
4.6.4.4	Over Current Protection: Circuit Description .....	36
4.7	Active Thermal Feedback.....	37
4.8	Power Management .....	37

4.8.1	Clock Control Architecture.....	37
4.8.2	Normal State .....	39
4.8.3	Auto Halt State .....	39
4.8.4	Stop Grant State .....	40
4.8.4.1	Quick Start State .....	40
4.8.5	HALT/GRANT Snoop State.....	41
4.8.6	Sleep State.....	41
4.8.7	Deep Sleep State .....	41
4.8.8	Currently Supported Clock States .....	42
4.8.9	Operating System Implications of the Quick Start and Sleep States .....	42
4.9	Typical POS/STR Power.....	42
<b>5.0</b>	<b>Mechanical Requirements .....</b>	<b>43</b>
5.1	Module Dimensions.....	43
5.1.1	Board Area .....	43
5.1.2	Module Pin 1 Location.....	44
5.1.3	Printed Circuit Board Thickness .....	45
5.1.4	Height Restrictions .....	45
5.2	Thermal Transfer Plate .....	46
5.3	Module Physical Support .....	47
5.3.1	Module Mounting Requirements .....	47
5.3.1.1	Module Weight .....	48
<b>6.0</b>	<b>Thermal Specifications .....</b>	<b>49</b>
<b>7.0</b>	<b>Labeling Information.....</b>	<b>49</b>
7.1	Product Tracking Code .....	49
7.1.1	Module Identification Bits .....	50
<b>8.0</b>	<b>Environmental Standards .....</b>	<b>50</b>

## Figures

1	Block Diagram of the Pentium II Processor – Low-Power Module.....	9
2	400-Pin Connector Footprint Pad Numbers, Module Secondary Side.....	21
3	BCLK, TCK, PICCLK Generic Clock Waveform at the Processor Core Pins.....	27
4	Power On Sequence Timing .....	30
5	V <sub>DC</sub> to V <sub>5</sub> Decoupling Circuit Example .....	32
6	Instantaneous In-Rush Current Model .....	33
7	Instantaneous In-Rush Current .....	33
8	Over Current Protection Circuit .....	34
9	Spice Simulation Using In Rush Protection.....	35
10	Pentium® II Processor – Low Power Clock Control States.....	38
11	Low-Power Module Board Dimensions .....	43
12	Low-Power Module Board Dimensions— Connector Pin 1 Orientation .....	44
13	PCB Board Thickness .....	44
14	Module Mechanical Drawing .....	45
15	Thermal Transfer Plate .....	46
16	Thermal Transfer Plate .....	47
17	Standoff Holes, Board Edge Clearance and EMI Containment Ring .....	48
18	Module Product Tracking Information .....	49

## Tables

1	Module Connector Signal Summary.....	10
2	Memory Signal Descriptions.....	11
3	AGP Signal Descriptions.....	12
4	PCI Signal Descriptions.....	13
5	Processor/PIIX4E Sideband Signal Descriptions.....	14
6	Power Management Signal Descriptions.....	15
7	Clock Signal Descriptions.....	16
8	Voltage Descriptions.....	17
9	ITP/JTAG Pins.....	17
10	Miscellaneous Pins.....	18
11	Connector Pin Assignments, Row A Through Row E.....	18
12	Connector Pin Assignments, Row F Through Row K.....	19
13	Connector Specifications.....	21
14	Configuration Straps for the 443BX Host Bridge/Controller.....	23
15	Power Supply Design Specifications.....	25
16	Module AC Specifications (BCLK) at the Processor Core.....	26
17	BCLK Signal Quality Specifications for Simulation at the Processor Core.....	27
18	Typical Voltage Regulator Efficiency.....	28
19	Voltage Signal Definitions and Sequences.....	29
20	Capacitance Requirement Per Power Plane.....	31
21	Thermal Sensor SMBUS Address.....	37
22	Processor Clock State Characteristics.....	39
23	Low-Power Clock States Supported by Processor.....	42
24	Low-Power Module Power Specifications.....	49
25	Environmental Standards.....	50

## Revision History

---

Revision	Date	Description
002	2/00	Removed references to Intel® Speedstep™ Technology (Geyserville). Added new section on VDC and V5 decoupling.
001	5/99	First publication of this document.

## 1.0 Introduction

---

The Pentium® II Processor – Low-Power Module is a fundamental building block for a system manufacturer to incorporate into a system. The Pentium II Processor – Low-Power Module incorporates a Pentium II processor –Low Power core, second-level cache with Tag RAM, Intel 443BX Host Bridge/Controller (Northbridge), voltage regulator, and an SMBus thermal sensor on a single printed circuit board.

Intel's host bridge architecture allows for physical partitioning at the PCI, AGP and DRAM interfaces; therefore the electrical interconnect defined for the module includes the PCI bus, AGP bus, DRAM memory bus and some host bridge sideband signals. An onboard voltage regulator provides the DC conversion from the system manufacturer's system DC voltage to the processor's core and I/O voltage. This isolation of the processor voltage requirements allows the system manufacturer to incorporate Low-Power Modules with different processor variants into a single system.

Building around this modular design gives the system manufacturer these advantages:

- Avoids complexities associated with designing high-speed processor core logic boards
- Provides an upgrade path from previous modules for designs using a standard interface

This document provides the technical information required to assist the OEM in developing the latest systems for the applied computing market segment.

## 1.1 Module Terminology

The following terms are used often in this document and are explained here for clarification:

**Pentium II processor – Low Power**—The central processing unit including cache components.

**Processor core**—The processor's execution engine.

**Thermal Transfer Plate (TTP)**—The surface used by the OEM to attach a system level thermal solution to the Pentium II Processor – Low-Power Module.

**Thermal Design Power (TDP)**—The typical power consumed by the CPU while executing a standard application.

## 2.0 Architecture Overview

---

The Pentium II Processor – Low-Power Module is a small, highly integrated assembly containing the Pentium II processor –Low Power core with internal/bus frequencies of 266/66 MHz and its immediate system-level support. The module interfaces electrically to its host system via a 3.3 V PCI bus, a 3.3 V AGP bus, a 3.3 V memory bus and the Intel 443BX Host Bridge/Controller.

The module includes a second-level cache of pipeline burst SRAM supporting up to 512 Kbytes. The ZZ "snooze" mode power management featured in previous modules is not supported. Instead it supports the "Stop Clock" mode of power management for the L2 SRAMs. In this mode, the clock signals to the L2 SRAMs are stopped or "parked" in a low power state by the processor.

The module contains key features of the Intel 443BX Host Bridge/Controller. The DRAM controller supports EDO at 3.3 V with a burst read at 7-2-2-2 (60 ns) or SDRAM at 3.3 V with a burst read at 8-1-1-1 (66 MHz, CL=2). The system controller provides a PCI CLKRUN# signal to request PIIX4E to start or maintain the PCI clock on the PCI bus. The 82443BX clock enable support enables Self Refresh mode of EDO or SDRAM during Suspend mode and is compatible with SMRAM (C\_SMRAM) and Extended SMRAM (E\_SMRAM) modes of power management; E\_SMRAM mode supports write-back cacheable SMRAM up to 1 Mbyte. The Intel 443BX Host Bridge/Controller is a 3.3 V PCI bus control which is compliant with PCI Rev 2.1 specifications.

The 443BX Host Bridge/Controller is one of two physical VLSI devices that constitute the Intel 440BX AGPset. The second device (Southbridge) is known as the PIIX4E PCI/ISA bridge. The system manufacturer's system electronics, which connect to the module, must include a PIIX4E device. The PIIX4E provides extensive power management capabilities and is designed to support the 82443BX in the module.

The processor core voltage regulation supports input voltages from 5 V to 21 V, enabling an above 80 percent peak efficiency. The regulator decouples processor voltage requirements from the system.

The module incorporates Active Thermal Feedback (ATF) sensing compliant to the ACPI Rev 1.0 specification. This is accomplished by including an SMBus compliant thermal sensor capable of supporting internal and external temperature sensing with programmable trip points.

A thermal transfer plate for heat dissipation from the processor and 443BX provides a standard thermal attach point to which the system manufacturer connects a system thermal solution.

Figure 1 illustrates the block diagram of the Pentium II Processor – Low-Power Module.

Figure 1. Block Diagram of the Pentium II Processor – Low-Power Module

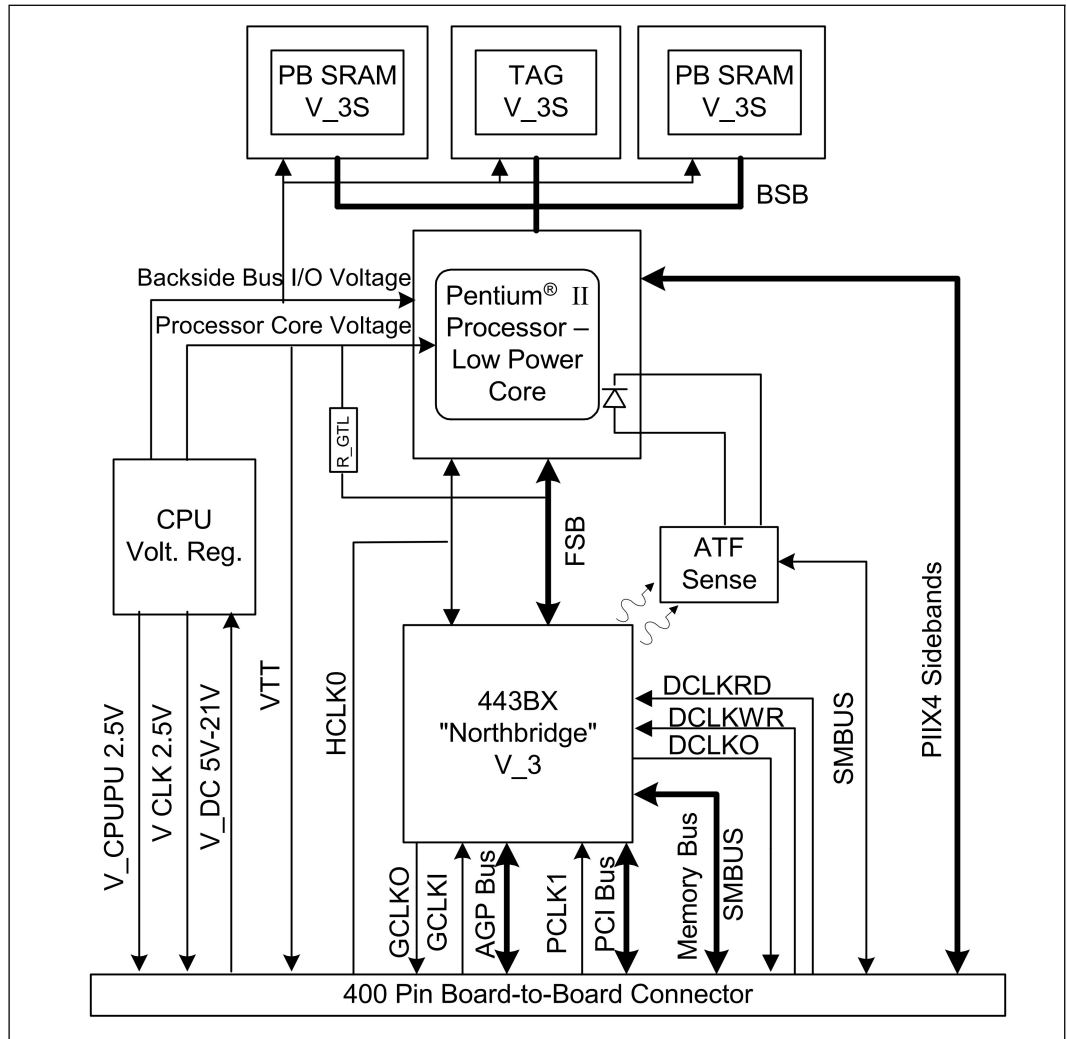

## 3.0 Module Connector Interface

### 3.1 Signal Definitions

Table 1 provides a list of signals by category and the corresponding number of signals in each category. For proper signal termination, see the *Pentium® II Processor – Low Power Module at 266 MHz Design Guide* (order number 273212).

**Table 1. Module Connector Signal Summary**

Signal Group	Number
Memory	109
AGP	60
PCI	58
Processor/PIIX4E Sideband	8
Power Management	7
Clocks	9
Voltage: V_DC	20
Voltage: V_3S	9
Voltage: V_5	3
Voltage: V_3	16
Voltage: VCCAGP	4
Voltage: V_CPUPU	1
Voltage: V_CLK	1
ITP/JTAG	9
Module ID	4
Ground	45
Reserved	37
<b>TOTAL PINS</b>	<b>400</b>

#### 3.1.1 Signal List

The following notations are used to denote the signal type:

- I** Input pin
- O** Output pin
- O D** Open Drain Output pin. This pin requires a pull-up resistor.
- I D** Open Drain Input pin. This pin requires a pull-up resistor.
- I/O D** Input / Open Drain Output pin. This pin requires a pull-up resistor.
- I/O** Bidirectional Input/Output pin

The signal description also includes the type of buffer used for a particular signal:

<b>GTL+</b>	Open Drain GTL+ interface signal
<b>PCI</b>	PCI bus interface signals
<b>AGP</b>	AGP interface signals
<b>CMOS</b>	The Pentium II Processor – Low-Power Module has Low Voltage TTL compatible (LVTTTL) interfacing.

### 3.1.2 Memory (109 Signals)

Table 2 lists the Pentium II Processor – Low-Power Module memory interface signals.

**Table 2. Memory Signal Descriptions**

Name	Type	Voltage	Description
MECC[7:0]	I/O CMOS	V <sub>3</sub>	<b>Memory ECC Data:</b> These signals carry Memory ECC data during access to DRAM. These pins are implemented by design but not tested on the module.
RASA[5:0]# or CSA[5:0]#	O CMOS	V <sub>3</sub>	<b>Row Address Strobe (EDO):</b> These pins select the DRAM row. <b>Chip Select (SDRAM):</b> These pins activate the SDRAMs. SDRAM accepts any command when its CS# pin is active low.
CASA[7:0]# or DQMA[7:0]	O CMOS	V <sub>3</sub>	<b>Column Address Strobe (EDO):</b> These pins select the DRAM column. <b>Input/Output Data Mask (SDRAM):</b> These pins act as synchronized output enables during a read cycle and as a byte mask during a write cycle. <sup>1</sup>
MAB[9:0]# MAB[10] MAB[12:11]# MAB[13]	O CMOS	V <sub>3</sub>	<b>Memory Address (EDO/SDRAM):</b> This is the row and column address for DRAM. The 443BX Host Bridge/Controller has two identical sets of address lines (MAA and MAB#). The module supports only the MAB set of address lines. For additional addressing features, please refer to the <i>Intel 440BX AGPset</i> datasheet (Order Number 290633). <sup>2</sup>
MWEA#	O CMOS	V <sub>3</sub>	<b>Memory Write Enable (EDO/SDRAM):</b> MWEA# should be used as the write enable for the memory data bus.
SRASA#	O CMOS	V <sub>3</sub>	<b>SDRAM Row Address Strobe (SDRAM):</b> When active low, this signal latches Row Address on the positive edge of the clock. This signal also allows Row access and pre-charge.
SCASA#	O CMOS	V <sub>3</sub>	<b>SDRAM Column Address Strobe (SDRAM):</b> When active low, this signal latches Column Address on the positive edge of the clock. This signal also allows Column access.
CKE[5:0]	O CMOS	V <sub>3</sub>	<b>SDRAM Clock Enable (SDRAM):</b> SDRAM clock enable pin. When these signals are de-asserted, SDRAM enters power-down mode. Each row is individually controlled by its own clock enable.
MD[63:0]	I/O CMOS	V <sub>3</sub>	<b>Memory Data:</b> These signals are connected to the DRAM data bus. They are not terminated on the module.

**NOTES:**

1. DQMA signals are non-inverted now. Please refer to the 82443BX Spec Update.
2. MAB[13] is a non-inverted address signal now. Please refer to 82443BX Spec Update.

### 3.1.3 AGP (60 SIGNALS)

Table 3 lists the Pentium II Processor – Low-Power Module’s AGP interface signals.

**Table 3. AGP Signal Descriptions (Sheet 1 of 2)**

Name	Type	Voltage	Description
GAD[31:0]	I/O AGP	V <sub>3</sub>	<b>AGP Address/Data:</b> The standard AGP address and data lines. This bus functions in the same way as the PCI AD[31:0] bus. The address is driven with FRAME# assertion, and data is driven or received in following clocks.
GC/BE[3:0]#	I/O AGP	V <sub>3</sub>	<b>AGP Command/Byte Enable:</b> This bus carries the command information during AGP cycles when PIPE# is being used. During an AGP write, this bus contains byte enable information. The command is driven with FRAME# assertion, and byte enables corresponding to supplied or requested data are driven on the following clocks.
GFRAME#	I/O AGP	V <sub>3</sub>	<b>AGP Frame:</b> Not used during AGP transactions. Remains de-asserted by an internal pullup resistor. Assertion indicates the address phase of a PCI transfer. Negation indicates that one more data transfer is desired by the cycle initiator.
GDEVSEL#	I/O AGP	V <sub>3</sub>	<b>AGP Device Select:</b> Same function as PCI DEVSEL#. Not used during AGP transactions. This signal is driven by the 443BX Host Bridge/Controller when a PCI initiator is attempting to access DRAM. DEVSEL# is asserted at medium decode time.
GIRDY#	I/O AGP	V <sub>3</sub>	<b>AGP Initiator Ready:</b> Indicates the AGP compliant target is ready to provide ALL write data for the current transaction. Asserted when the initiator is ready for a data transfer.
GTRDY#	I/O AGP	V <sub>3</sub>	<b>AGP Target Ready:</b> Indicates the AGP compliant master is ready to provide ALL write data for the current transaction. Asserted when the target is ready for a data transfer.
GSTOP#	I/O AGP	V <sub>3</sub>	<b>AGP Stop:</b> Same function as PCI STOP#. Not used during AGP transactions. Asserted by the target to request the master to stop the current transaction.
GREQ#	I AGP	V <sub>3</sub>	<b>AGP Request:</b> AGP master requests for AGP.
GGNT#	O AGP	V <sub>3</sub>	<b>AGP Grant:</b> Same function as on PCI. Additional information is provided on the ST[2:0] bus. PCI Grant: Permission is given to the master to use PCI.
GPAR	I/O AGP	V <sub>3</sub>	<b>AGP Parity:</b> A single parity bit is provided over GAD[31:0] and GC/BE[3:0]. This signal is not used during AGP transactions.
PIPE#	I AGP	V <sub>3</sub>	<b>Pipelined Request:</b> Asserted by the current master to indicate a full width address is to be queued by the target. The master queues one request each rising clock edge while PIPE# is asserted.
SBA[7:0]	I AGP	V <sub>3</sub>	<b>Sideband Address:</b> This bus provides an additional conduit to pass address and commands to the 443BX Host Bridge/Controller from the AGP master.
RBF#	I AGP	V <sub>3</sub>	<b>Read Buffer Full:</b> Indicates if the master is ready to accept previously requested low priority read data.

**Table 3. AGP Signal Descriptions (Sheet 2 of 2)**

Name	Type	Voltage	Description
ST[2:0]	O AGP	V <sub>3</sub>	<b>Status Bus:</b> Provides information from the arbiter to a AGP Master on what it may do. These bits only have meaning when GGNT is asserted.
ADSTB[B:A]	I/O AGP	V <sub>3</sub>	<b>AD Bus Strobes:</b> Provide timing for double clocked data on the GAD bus. The agent that is providing data drives these signals. These are identical copies of each other.
SBSTB	I AGP	V <sub>3</sub>	<b>Sideband Strobe:</b> Provides timing for a side-band bus. It is always driven by the agent driving SBA[7:0], i.e., by the AGP master.

### 3.1.4 PCI (58 SIGNALS)

Table 4 lists the Pentium II Processor – Low-Power Module’s PCI interface signals.

**Table 4. PCI Signal Descriptions (Sheet 1 of 2)**

Name	Type	Voltage	Description
AD[31:0]	I/O PCI	V <sub>3</sub>	<b>Address/Data:</b> The standard PCI address and data lines. The address is driven with FRAME# assertion, and data is driven or received in following clocks.
C/BE[3:0]#	I/O PCI	V <sub>3</sub>	<b>Command/Byte Enable:</b> The command is driven with FRAME# assertion, and byte enables corresponding to supplied or requested data are driven on the following clocks.
FRAME#	I/O PCI	V <sub>3</sub>	<b>Frame:</b> Assertion indicates the address phase of a PCI transfer. Negation indicates that one more data transfers are desired by the cycle initiator.
DEVSEL#	I/O PCI	V <sub>3</sub>	<b>Device Select:</b> This signal is driven by the 443BX Host Bridge/Controller when a PCI initiator is attempting to access DRAM. DEVSEL# is asserted at medium decode time.
IRDY#	I/O PCI	V <sub>3</sub>	<b>Initiator Ready:</b> Asserted when the initiator is ready for data transfer.
TRDY#	I/O PCI	V <sub>3</sub>	<b>Target Ready:</b> Asserted when the target is ready for a data transfer.
STOP#	I/O PCI	V <sub>3</sub>	<b>Stop:</b> Asserted by the target to request the master to stop the current transaction.
PLOCK#	I/O PCI	V <sub>3</sub>	<b>Lock:</b> Indicates an exclusive bus operation and may require multiple transactions to complete. When LOCK# is asserted, non-exclusive transactions may proceed. The 443BX supports lock for processor initiated cycles only. PCI initiated locked cycles are not supported
REQ[4:0]#	I PCI	V <sub>3</sub>	<b>PCI Request:</b> PCI master requests for PCI.
GNT[4:0]#	O PCI	V <sub>3</sub>	<b>PCI Grant:</b> Permission is given to the master to use PCI.

Table 4. PCI Signal Descriptions (Sheet 2 of 2)

Name	Type	Voltage	Description
PHOLD#	I PCI	V <sub>3</sub>	<b>PCI Hold:</b> This signal comes from the expansion bridge; it is the bridge request for PCI. The 443BX Host Bridge drains the DRAM write buffers, drains the processor-to-PCI posting buffers, and acquires the host bus before granting the request via PHLDA#. This ensures that GAT timing is met for ISA masters. The PHOLD# protocol has been modified to include support for passive release.
PHLDA#	O PCI	V <sub>3</sub>	<b>PCI Hold Acknowledge:</b> This signal is driven by the 443BX Host Bridge to grant PCI to the expansion bridge. The PHLDA# protocol has been modified to include support for passive release.
PAR	I/O PCI	V <sub>3</sub>	<b>Parity:</b> A single parity bit is provided over AD[31:0] and C/BE[3:0]#
SERR#	I/O PCI	V <sub>3</sub>	<b>System Error:</b> The 443BX asserts this signal to indicate an error condition. Please refer to the <i>Intel 440BX AGPset</i> datasheet (order number 290633) for further information.
CLKRUN#	I/O D PCI	V <sub>3</sub>	<b>Clock Run:</b> An open-drain output and also an input. The 443BX Host Bridge requests the central resource (PIIX4E) to start or maintain the PCI clock by asserting CLKRUN#. The 443BX Host Bridge three-states CLKRUN# upon deassertion of Reset (since CLK is running upon deassertion of Reset).
PCI_RST#	I CMOS	V <sub>3</sub>	<b>Reset:</b> When asserted, this signal asynchronously resets the 443BX Host Bridge. The PCI signals also three-state, compliant with PCI Rev 2.1 specifications.

### 3.1.5 Processor/PIIX4E Sideband (8 Signals)

Table 5 lists the module's processor and PIIX4E sideband signals at the connector interface. The voltage level for these signals is determined by V<sub>CPUPU</sub>, which is supplied by the module.

Table 5. Processor/PIIX4E Sideband Signal Descriptions (Sheet 1 of 2)

Name	Type	Voltage	Description
FERR#	O CMOS	V <sub>CPUPU</sub>	<b>Numeric Coprocessor Error:</b> This pin functions as a FERR# signal supporting coprocessor errors. This signal is tied to the coprocessor error signal on the processor and is driven by the processor to the PIIX4E.
IGNNE#	I D CMOS	V <sub>CPUPU</sub>	<b>Ignore Error:</b> This open drain signal is connected to the ignore error pin on the processor and is driven by the PIIX4E.
INIT#	I D CMOS	V <sub>CPUPU</sub>	<b>Initialization:</b> INIT# is asserted by the PIIX4E to the processor for system initialization. This signal is an open drain.
INTR	I D CMOS	V <sub>CPUPU</sub>	<b>Processor Interrupt:</b> INTR is driven by the PIIX4E to signal the processor that an interrupt request is pending and needs to be serviced. This signal is an open drain.
NMI	I D CMOS	V <sub>CPUPU</sub>	<b>Non-Maskable Interrupt:</b> NMI is used to force a non-maskable interrupt to the processor. The PIIX4E ISA bridge generates an NMI when either SERR# or IOCHK# is asserted, depending on how the NMI Status and Control Register is programmed. This signal is an open drain.

**Table 5. Processor/PIIX4E Sideband Signal Descriptions (Sheet 2 of 2)**

Name	Type	Voltage	Description
A20M#	I D CMOS	V_CPUPU	<b>Address Bit 20 Mask:</b> When enabled, this open drain signal causes the processor to emulate the address wraparound at one Mbyte which occurs on the Intel 8086 processor.
SMI#	I D CMOS	V_CPUPU	<b>System Management Interrupt:</b> SMI# is an active low synchronous output from the PIIX4E that is asserted in response to one of many enabled hardware or software events. The SMI# open drain signal can be an asynchronous input to the processor. However, in this chip set SMI# is synchronous to PCLK.
STPCLK#	I D CMOS	V_CPUPU	<b>Stop Clock:</b> STPCLK# is an active low synchronous open drain output from the PIIX4E that is asserted in response to one of many hardware or software events. STPCLK# connects directly to the processor and is synchronous to PCICLK. When the processor samples STPCLK# asserted it responds by entering a low power state (Quick Start). The processor will only exit this mode when this signal is de-asserted.

### 3.1.6 Power Management (7 Signals)

Table 6 lists the module’s Power Management signals. The SM\_CLK and SM\_DATA signals refer to the two-wire serial SMBus interface. Although this interface is currently used solely for the digital thermal sensor thermal sensor, there are reserved serial addresses for future use. See “Active Thermal Feedback” on page 37 for more details.

**Table 6. Power Management Signal Descriptions**

Name	Type	Voltage	Description
SUS_STAT1#	I CMOS	V_3ALWAYS†	<b>Suspend Status:</b> This signal connects to the SUS_STAT1# output of PIIX4E. It provides information on host clock status and is asserted during all suspend states.
VR_ON	I CMOS	V_3S	<b>VR_ON:</b> Voltage regulator ON. This 3.3 V (5 V tolerant) signal controls the operation of the module’s voltage regulator. VR_ON should be generated as a function of the PIIX4E SUSB# signal which is used for controlling the “Suspend State B” voltage planes.
VR_PWRGD	O	V_3S	<b>VR_PWRGD:</b> This signal is driven high by the to indicate the voltage regulator is stable and is pulled low using a 131.6K resistor when inactive. It can be used in some combination to generate the system PWRGOOD signal.
BXPWROK	I CMOS	V_3	<b>Power OK to BX:</b> This signal must go active 1mS after the V_3 power rail is stable.
SM_CLK	I/O D CMOS	V_3	<b>Serial Clock:</b> This clock signal is used on the SMBUS interface to the digital thermal sensor.
SM_DATA	I/O D CMOS	V_3	<b>Serial Data:</b> Open-drain data signal on the SMBUS interface to the digital thermal sensor.
ATF_INT#	O D CMOS	V_3	<b>ATF Interrupt:</b> This signal is an open-drain output signal of the digital thermal sensor.

† V\_3ALWAYS: 3.3 V voltage supply. It is generated whenever V\_DC is available and supplied to the PIIX4E resume well.

### 3.1.7 Clock (9 Signals)

Table 7 lists the module's clock signals.

**Table 7. Clock Signal Descriptions**

Name	Type	Voltage	Description
PCLK	I PCI	V_3S	<b>PCI Clock In:</b> PCLK is an input to the module is one of the system's PCI clocks. This clock is used by all of the 443BX Host Bridge logic in the PCI clock domain. This clock is stopped when the PIIX4E PCI_STP# signal is asserted and/or during all suspend states.
HCLK[1:0]	I CMOS	V_CLK	<b>Host Clock In:</b> Only HCLK0 is an input to the module from the CK100-M clock source and is used by the processor and 443BX Host Bridge/Controller. HCLK0 is the only clock input supplied to the module. This clock is stopped when the PIIX4E CPU_STP# signal is asserted and/or during all suspend states.
DCLKO	O CMOS	V_3	<b>SDRAM Clock Out:</b> 66 MHz SDRAM clock reference generated internally by the 443BX Host Bridge/Controller onboard PLL. It feeds an external buffer that produces multiple copies for the SODIMMs.
DCLKRD	I CMOS	V_3	<b>SDRAM Read Clock:</b> Feedback reference from the SDRAM clock buffer. This clock is used by the 443BX Host Bridge/Controller when reading data from the SDRAM array.
DCLKWR	I CMOS	V_3	<b>SDRAM Write Clock:</b> Feedback reference from the SDRAM clock buffer. This clock is used by the 443BX Host Bridge/Controller when writing data to the SDRAM array.
GCLKIN	I CMOS	V_3	<b>AGP Clock In:</b> The GCLKIN input is a feedback reference from the GCLKO signal.
GCLKO	O CMOS	V_3	<b>AGP Clock Out:</b> This signal is generated by the 443BX Host Bridge/Controller onboard PLL from the HCLK0 host clock reference. The frequency of GCLKO is 66 MHz. The GCLKO output is used to feed both the PLL reference input pin on the 443BX Host Bridge/Controller and the AGP device. The board layout must maintain complete symmetry on loading and trace geometry to minimize AGP clock skew.
FQS	O CMOS	V_3S	<b>Frequency Select:</b> This output signal provides the status of the host clock frequency to the system electronics. This signal is static and is pulled either low or high to the V_CLK voltage supply through a 10-K $\Omega$ resistor. This module is designed for the 66-MHz strapping option shown below. FQS=0 indicates 66 MHz FQS=1 indicates 100 MHz (for future modules)

### 3.1.8 Voltages (54 Signals)

Table 8 lists the module’s voltage signal definitions.

**Table 8. Voltage Descriptions**

Name	Type	Number	Description
V_DC	I	20	<b>DC Input:</b> 5 - 21 V
V_3S	I	9	<b>SUSB# controlled 3.3 V:</b> Power-managed 3.3 V voltage supply. An output of the voltage regulator on the system electronics. This rail is off during STR, STD, and SOff.
V_5	I	3	<b>SUSC# controlled 5 V:</b> Power-managed 5 V voltage supply. An output of the voltage regulator on the system electronics. This rail is off during STD and SOff.
V_3	I	16	<b>SUSC# controlled 3.3 V:</b> Power-managed 3.3 V voltage supply. An output of the voltage regulator on the system electronics. This rail is off during STD and SOff.
VCCAGP	I	4	<b>AGP I/O Voltage:</b> For this revision of the module, this rail must be connected to V_3.
V_CPUPU	O	1	<b>Processor I/O Ring:</b> Driven by the module to power processor interface signals such as the PIIX4E open-drain pullups for the processor/PIIX4E sideband signals.
V_CLK	O	1	<b>Processor Clock Rail:</b> Driven by the module to power the CK100-M VDDCPU rail.

### 3.1.9 ITP/JTAG (9 Signals)

Table 9 lists the module’s ITP/JTAG signals, which the system electronics can use to implement a JTAG chain and ITP port, if desired.

**Table 9. ITP/JTAG Pins**

Name	Type	Voltage	Description
TDO	O	V_CPUPU	<b>JTAG Test Data Out:</b> Serial output port. TAP instructions and data are shifted out of the processor from this port.
TDI	I	V_CPUPU	<b>JTAG Test Data In:</b> Serial input port. TAP instructions and data are shifted into the processor from this port.
TMS	I	V_CPUPU	<b>JTAG Test Mode Select:</b> Controls the TAP controller change sequence.
TCLK	I	V_CPUPU	<b>JTAG Test Clock:</b> Testability clock for clocking the JTAG boundary scan sequence.
TRST#	I	V_CPUPU	<b>JTAG Test Reset:</b> Asynchronously resets the TAP controller in the processor.
FS_RESET#	O	GTL+	<b>Processor Reset:</b> Processor reset status to the ITP.
VTT	O	V_Core	<b>GTL+ Termination Voltage:</b> Used by the POWERON pin on the ITP debug port to determine when target system is on. POWERON pin is pulled up using a 1 KΩ resistor to VTT.
FS_PREQ#	I	V_CPUPU	<b>Debug Mode Request:</b> Driven by the ITP - makes request to enter debug mode.
FS_PRDY#	O	GTL+	<b>Debug Mode Ready:</b> Driven by the processor - informs the ITP that the processor is in debug mode.

**NOTE:** Recommendation: DBREST# (reset target system) on the ITP debug port can be “logically AND’ed” with the signal VR\_PWRGD and connected to the PIIX4E input PWROK.

### 3.1.10 Miscellaneous (82 Signals)

Table 10 lists the module’s miscellaneous signal pins.

**Table 10. Miscellaneous Pins**

Name	Type	Number	Description
Module ID[3:0]	○ CMOS	4	<b>Module Revision ID:</b> These pins track the revision level of the processor module. A 100 KΩ pull up resistor to V_3S is required on these signals and to be placed on the system electronics for these signals.
Ground	I	45	<b>Ground</b>
Reserved	RSVD	37	Unallocated <b>Reserved</b> pins and should not be connected.

## 3.2 Connector Pin Assignments

Table 11 and Table 12 list the signals for each pin of the connector from the module to the system electronics. Refer to “Pin and Pad Assignments” on page 20 for the pin assignments of the pads on the connector.

**Table 11. Connector Pin Assignments, Row A Through Row E (Sheet 1 of 2)**

Pin#	Row A	Row B	Row C	Row D	Row E
1	SBA5	ADSTBB	Gnd	GAD31	SBA7
2	GAD25	GAD24	SBA6	SBA4	SBA0
3	GAD30	GAD29	GAD26	GAD27	Gnd
4	Gnd	VCCAGP	GAD4	GAD6	GAD8
5	RBF#	GAD1	GAD3	GAD5	GC/BE0#
6	BXPWROK	Reserved	GAD2	ADSTBA	Gnd
7	MD0	MD1	V_3	CLKRUN#	GAD7
8	MD2	MD33	Gnd	MD32	GAD0
9	MD36	MD4	MD3	MD35	MD34
10	MD7	MD38	MD37	MD6	MD5
11	MD41	MD42	MD40	MD39	MD8
12	MD43	MD11	Gnd	MD10	MD9
13	MD14	MD45	MD44	MD13	MD12
14	MECC4	MECC0	MD15	MD47	MD46
15	SCASA#	WEA#	MECC5	Reserved	Gnd
16	Gnd	MID1	DQMA0	DQMA1	Reserved
17	V_3	DQMA4	MID0	DQMA5	CSA0#
18	CSA1#	CSA2#	CSA4#	CSA3#	Gnd
19	SRASA#	CSA5#	MAB0#	MAB1#	Reserved
20	Reserved	Reserved	MAB2#	Reserved	MAB3#
21	Reserved	MAB4#	Gnd	Reserved	MAB6#

**Table 11. Connector Pin Assignments, Row A Through Row E (Sheet 2 of 2)**

Pin#	Row A	Row B	Row C	Row D	Row E
22	Reserved	Reserved	MAB5#	Reserved	MAB7#
23	MAB8#	Reserved	Reserved	MAB9#	MAB10
24	Reserved	MAB11#	MAB12#	Reserved	DCLKO
25	MAB13	V_3	Gnd	CKE0	DCLKRD
26	CKE1	MID2	CKE3	CKE4	Gnd
27	CKE5	CKE2	MID3	Reserved	Reserved
28	Reserved	Reserved	DQMA2	DCLKWR	Gnd
29	Gnd	VTT	Reserved	FS_PREQ#	DQMA3
30	FS_RESET#	V_3	MD26	Gnd	MD25
31	FS_PRDY#	Gnd	MD58	MD57	MD60
32	Reserved	SMCLK	TDO	TCLK	FERR#
33	Reserved	SMDAT	TDI	TMS	IGNNE#
34	Reserved	FQS	Reserved	TRST#	ATF_INT#
35	Reserved	V_5	V_3S	V_3S	V_3S
36	V_CPUPU	V_5	V_3S	V_3S	V_3S
37	V_CLK	V_5	V_3S	V_3S	V_3S
38	Reserved	Reserved	Reserved	Reserved	Reserved
39	V_DC	V_DC	V_DC	V_DC	V_DC
40	V_DC	V_DC	V_DC	V_DC	V_DC

**Table 12. Connector Pin Assignments, Row F Through Row K (Sheet 1 of 2)**

Pin#	Row F	Row G	Row H	Row J	Row K
1	GREQ#	Gnd	PIPE#	SBA3	Gnd
2	ST0	ST1	SBA1	SBSTB	GCLKI
3	GGNT#	ST2	SBA2	Gnd	GCLKO
4	GAD13	GSTOP#	GAD16	GAD20	GAD23
5	GAD12	GPAR	GAD18	GAD17	GC/BE3#
6	GAD10	GAD15	GFRAME#	Gnd	GAD22
7	GAD11	GC/BE1#	GTRDY#	GC/BE2#	GAD21
8	GAD9	GAD14	GDEVSEL#	GIRDY#	GAD19
9	Gnd	VCCAGP	Gnd	VCCAGP	GAD28
10	AD0	AD4	AD2	AD3	AD1
11	Gnd	C/BE0#	AD6	Gnd	AD5
12	VCCAGP	AD10	AD7	AD8	AD9
13	MECC1	AD13	Gnd	AD12	AD11
14	SERR#	PAR	AD15	C/BE1#	AD14
15	AD16	TRDY#	STOP#	DEVSEL#	PLOCK#

Table 12. Connector Pin Assignments, Row F Through Row K (Sheet 2 of 2)

Pin#	Row F	Row G	Row H	Row J	Row K
16	AD19	Gnd	AD17	Gnd	AD18
17	AD23	AD30	AD24	C/BE2#	AD21
18	AD27	AD22	C/BE3#	AD26	PCLK
19	PCI_RST#	Gnd	AD20	AD28	Gnd
20	Reserved	PHOLD#	AD31	AD29	AD25
21	IRDY#	FRAME#	Gnd	REQ1#	REQ0#
22	Gnd	GNT2#	REQ2#	REQ3#	GNT3#
23	GNT1#	GNT4#	GNT0#	REQ4#	Gnd
24	Gnd	PHLDA#	Gnd	V_3	MD59
25	DQMA6	MECC7	MD50	MD51	MD54
26	MECC2	MD48	MD18	MD52	MD24
27	DQMA7	MD16	MD19	Gnd	MD23
28	MECC6	MD17	MD21	MD53	MD55
29	MECC3	MD49	MD20	MD22	MD56
30	MD27	MD28	Gnd	MD62	MD63
31	Gnd	MD29	MD61	MD30	MD31
32	SMI#	INTR	VR_ON	Gnd	Gnd
33	NMI	SUS_STAT1#	VR_PWRGD	Gnd	HCLK0
34	A20M#	STPCLK#	INIT#	Gnd	Gnd
35	V_3	V_3	V_3	Gnd	HCLK1
36	V_3	V_3	V_3	Gnd	Gnd
37	V_3	V_3	V_3	V_3	V_3
38	Reserved	Reserved	Reserved	Reserved	Reserved
39	V_DC	V_DC	V_DC	V_DC	V_DC
40	V_DC	V_DC	V_DC	V_DC	V_DC

### 3.3 Pin and Pad Assignments

The module connector is a surface mount, 1.27 mm pitch BGA style, 400-pin connector. There are currently three unique mating connector receptacles that are available for the module from Berg Electronics (part number 74219-002).

Figure 2 shows the connector pad assignments for the manufacturer's system electronics. This footprint is viewed from the secondary side of the processor module (the side of the printed circuit board on which the 400-pin connector is soldered).

Figure 2. 400-Pin Connector Footprint Pad Numbers, Module Secondary Side

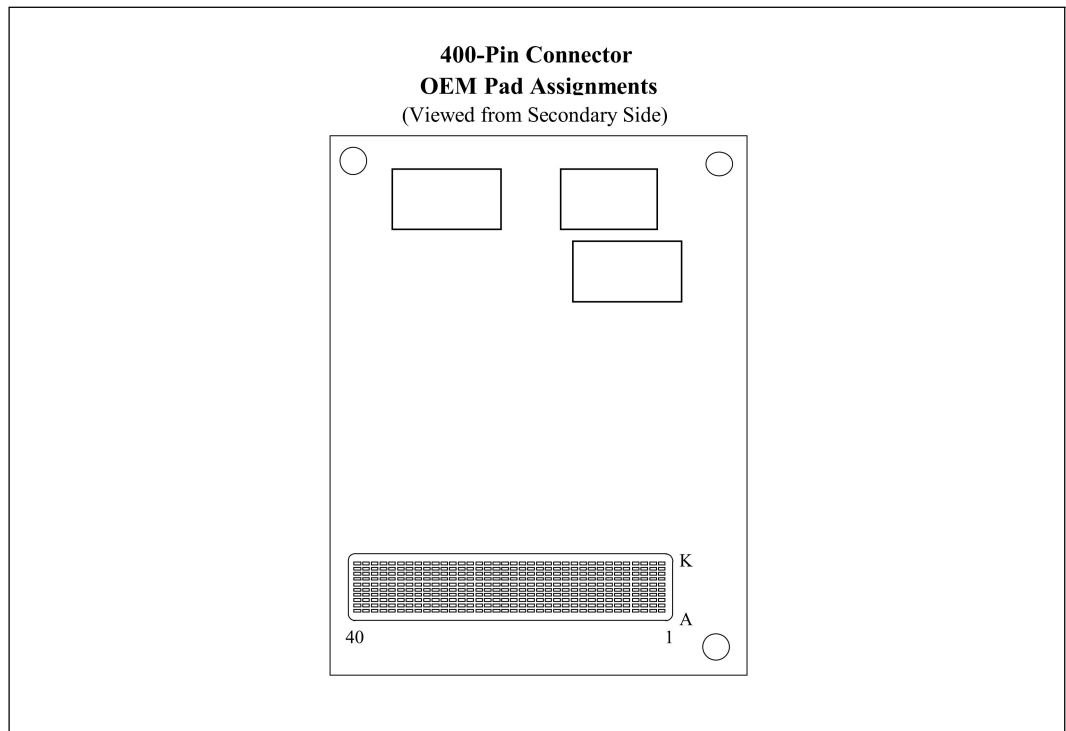

Table 13 summarizes some of the more critical specifications for the connector.

Table 13. Connector Specifications

Parameter	Condition	Specification
Material	Contact	Copper Alloy
	Housing	Thermo Plastic Molded Compound: LCP
Electrical	Current	0.5 A
	Voltage	50 V AC
	Insulation Resistance	100 MΩ min. @ 500 VDC
	Termination Resistance	20mΩ max. @ 20mV open circuit with 10mA
	Capacitance	5 pF max. Per contact
Mechanical	Mating Cycles	50 cycles
	Connector Mating Force	0.9 N (90 gf) max. Per contact
	Contact Un-mating Force	0.1 N (10 gf) min. Per contact

## 4.0 Functional Description

---

### 4.1 Low-Power Module

The Pentium II Processor – Low-Power Module supports the Pentium II Processor – Low Power core running 266/66 MHz with 32 Kbyte L1 code and data cache sizes.

### 4.2 L2 Cache

The processor core's internal cache is complimented with a second-level cache using a high-performance pipeline burst SRAM which uses a dedicated high speed bus into the processor core. The L2 cache can support 512 Mbytes of system memory, while the maximum amount of cacheable system memory supported by the 443BX Host Bridge/Controller is 256 Mbytes with 16 Mbit DRAMs. (The system controller can support up to 1 Gbytes of system memory using 64-Mbit technology.) The module has two 100-pin TQFP footprints for 512 Kbyte direct-mapped write-back L2 cache.

The module supports the “Stop Clock” mode of power management for the L2 SRAMs. In this mode, the clock signals to the synchronous SRAMs are stopped or “parked” in a low-power state.

### 4.3 443BX Host Bridge/Controller

Intel's 443BX Host Bridge/Controller is a highly integrated device that combines the bus controller, the DRAM controller, and the PCI bus controller into one component. The 443BX Host Bridge has multiple power management features for low-power systems:

- CLKRUN# is a feature that enables controlling of the PCI clock on or off
- 443BX Host Bridge suspend modes include Suspend-to-RAM (STR), Suspend-to-Disk (STD) and Powered-On-Suspend (POS)
- System Management RAM (SMRAM) power management modes include Compatible SMRAM (C\_SMRAM) and Extended SMRAM (E\_SMRAM). C\_SMRAM is the traditional SMRAM feature implemented in all Intel PCI chipsets. E\_SMRAM is a new feature that supports write-back cacheable SMRAM space up to 1 Mbyte. To minimize power consumption while the system is idle, the internal 443BX Host Bridge clock is turned off (gated off) when there is no processor and PCI activity.

The module supports only the 443BX Host Bridge/Controller features in “mobile compatible” or legacy mode. Refer to the *Intel 440BX AGPset: 82443BX Host Bridge/Controller* datasheet (order number 290633) for complete details.

### 4.3.1 Memory Organization

The complete memory interface of the 443BX Host Bridge/Controller is available at the module’s connector; all of the 443BX standard Mode memory configurations and modes of operation are supported on the signaling interface. This allows the memory interface to support the following:

- One set of memory control signals, sufficient to support up to three SO\_DIMM sockets and six banks of SDRAM at 66 MHz
- One CKE signal for each banks

Key memory features not supported by the 443BX Host Bridge/Controller standard Mode are:

- Support for eight banks of memory
- Second set of memory address lines (MAA[13:0])
- 100 MHz SDRAM (and Front Side Bus)

DRAM technologies supported by 443BX Host Bridge/Controller include Extended Data Out (EDO) and SDRAM. These memory types may not be mixed in the system. In other words, all DRAM in all rows (RAS[5:0]#) must be of the same technology. The 443BX Host Bridge/Controller targets 60 ns EDO DRAMs. and 66 MHz SDRAMs.

The module’s clocking architecture supports the use of SDRAM. Due to the tight timing requirements of 66-MHz SDRAM clocks, the clocking mode for SDRAM or system manufacturer custom memory configurations allows all host and SDRAM clocks to be generated from the same clocking architecture on the OEM’s system electronics. For complete details about using SDRAM memory, and for trace length guidelines, see the *Pentium® II Processor – Low Power Module at 266 MHz – 66 MHz SDRAM DIMM Routing Guidelines* (order number 273230).

For details on memory device support, organization, size and addressing, refer to the *Intel 440BX AGPset: 82443BX Host Bridge/Controller* datasheet (order number 290633).

### 4.3.2 Reset Strap Options

The 443BX Host Bridge/Controller has several strap options on the memory address bus which define the behavior of the device after reset. For the module, several of these strap options are implemented on the module. Other straps are allowed to override the default settings. Table 14 shows the various straps and how they are handled by the module.

**Table 14. Configuration Straps for the 443BX Host Bridge/Controller**

Signal	Function	Module Default Setting	Optional Override on System Electronics
MAB[12]#	Host Frequency Select	No strap. (66 MHz default)	None
MA[11]#	In Order Queue Depth	No strap. (Maximum Queue Depth is set (i.e., 8))	None
MA[10]	Quick Start Select	Strapped high on the module for Quick Start mode.	None
MA[9]#	AGP disable	No strap. AGP is enabled	Pull up this signal to disable AGP interface.
MA[7]#	MM Config	No strap. Standard mode.	None
MA[6]#	Host Bus Buffer Mode Select	Strapped high on the module for FSB buffers.	None

### 4.3.3 PCI Interface

The 443BX Host Bridge/Controller is compliant with the PCI 2.1 specification, which improves the worst-case PCI bus access latency from earlier PCI specifications. The complete PCI interface of the 443BX Host Bridge/Controller is available at the connector. The 443BX Host Bridge/Controller supports the PCI Clockrun protocol for PCI bus power management. In this protocol, PCI devices assert the CLKRUN# open-drain signal when they require the use of the PCI interface.

The 443BX Host Bridge/Controller is responsible for arbitrating the PCI bus. Since the module is configured in “mobile compatible” or legacy mode, the 443BX Host Bridge/Controller can support only up to five PCI bus masters. There are five PCI Request/Grant pairs, REQ[4:0]# and GNT[4:0]#, available on the connector to the manufacturer’s system electronics.

The PCI interface on the module is 3.3 V only. 5 V PCI devices are not supported, specifically all devices which drive outputs to a 5 V nominal Voh level.

The 443BX Host Bridge/Controller supports only Mechanism #1 for accessing PCI configuration space, as detailed in the PCI specification. This implies that signals AD[31:11] are available for PCI IDSEL signals. However, since the 443BX Host Bridge is always device #0; AD11 will never be asserted during PCI configuration cycles as an IDSEL. AD12 is reserved by the 443BX for the AGP bus. Thus, AD13 is the first available address line usable as an IDSEL. AD18 is recommended to be used by the PIIX4E Southbridge.

### 4.3.4 AGP Interface

The 443BX Host Bridge/Controller is compliant with the AGP Rev. 1.0 specification, which supports only an asynchronous AGP interface coupling to the 443BX core frequency. The AGP interface can reach a theoretical ~500 Mbytes/s transfer rate (i.e., using AGP 2X/133 devices). The actual bandwidth will be limited by the capability of the 443BX memory subsystem.

## 4.4 Electrical Requirements

The following section provides information on the DC requirements for the module.

### 4.4.1 DC Requirements

Refer to Table 15 for power supply design criteria to ensure compliance with the module’s DC power requirements.

**Table 15. Power Supply Design Specifications**

Symbol	Parameter	Min	Nom	Max	Unit	Notes <sup>1</sup>
V <sub>DC</sub>	DC Input Voltage	5.0	12.0	21.0	V	
I <sub>DC</sub> <sup>1,2</sup>	DC Input Current	0.1	0.9	3.5	A	
I <sub>DC-Surge</sub>	Maximum Surge Current for V <sub>DC</sub>			17.3	A	
I <sub>DC-Leakage</sub> <sup>3</sup>	Typical Leakage Current for V <sub>DC</sub>		4.0		μA	(At 25° C)
V <sub>5</sub>	Power Managed 5V Voltage Supply	4.75	5.0	5.25	V	
I <sub>5</sub>	Power Managed 5V Current	17	32	60	mA	
I <sub>5-Surge</sub>	Maximum Surge Current for V <sub>5</sub>			0.6	A	
I <sub>5-Leakage</sub>	Typical Leakage Current for V <sub>5</sub>		1.0		μA	
V <sub>3</sub>	Power Managed 3.3V Voltage Supply	3.135	3.3	3.465	V	
I <sub>3</sub>	Power Managed 3.3V Current	0.8	1.2	2.0	A	
I <sub>3-Surge</sub>	Maximum Surge Current for V <sub>3</sub>			2.8	A	
I <sub>3-Leakage</sub>	Typical Leakage Current for V <sub>3</sub>		1.1		mA	
V <sub>CPUPU</sub>	Processor I/O Ring Voltage	2.375	2.5	2.625	V	± 0.125
I <sub>CPUPU</sub> <sup>4</sup>	Processor I/O Ring Current	0	10	20	mA	
V <sub>CLK</sub>	Processor Clock Rail Voltage	2.375	2.5	2.625	V	± 0.125
I <sub>CLK</sub> <sup>5</sup>	Processor Clock Rail Current	24.0	35.0	80	mA	

**NOTES:**

1. V<sub>DC</sub> is set for 12 V in order to determine typical V<sub>DC</sub> current.
2. V<sub>DC</sub> is set for 5 V in order to determine maximum V<sub>DC</sub> current.
3. Leakage current that can be expected when VR\_ON is deactivated and V<sub>DC</sub> is still applied.
4. These values are system dependent.

#### 4.4.2 AC Requirements

Please refer to Table 16 for module AC timing requirements for BCLK.

BCLK system timing is specified in terms of signal quality. The waveform of Figure 7 describes a typical system bus clock as seen at the processor core pin.

**Table 16. Module AC Specifications (BCLK) at the Processor Core Pins**

T#	Parameter	Min	Nom	Max	Unit	Figure	Notes <sup>1,2,3</sup>
	System Bus Frequency		66.67		MHz		All processor core frequencies <sup>4</sup>
T1:	BCLK Period		15.		ns		4, 5, 6
T2:	BCLK Period Stability			±250	ps		6, 7, 8, 9
T3:	BCLK High Time	5.3			ns		@>1.765 V <sup>6</sup>
T4:	BCLK Low Time	5.3			ns		@<0.5 V <sup>6</sup>
T5:	BCLK Rise Time	0.175		0.875	ns		(0.9 V–1.6 V) <sup>6,9</sup>
T6:	BCLK Fall Time	0.175		0.875	ns		(1.6 V–0.9 V) <sup>6,9</sup>

**NOTES:**

1. Unless otherwise noted, all specifications in this table apply to all modules.
2. All AC timings for the GTL+ signals are referenced to the BCLK rising edge at 1.25 V at the processor core pin. All GTL+ signal timings (address bus, data bus, etc.) are referenced at 1.00 V at the processor core pins.
3. All AC timings for the CMOS signals are referenced to the BCLK rising edge at 1.25 V at the processor core pin. All CMOS signal timings (compatibility signals, etc.) are referenced at 1.25 V at the processor core pins.
4. The internal core clock frequency is derived from the system bus clock. The system bus clock to core clock ratio is determined during initialization as described and is predetermined by the module.
5. The BCLK period allows a +0.5 ns tolerance for clock driver variation. See the *CK97 Clock Synthesizer/Driver Specification* for further information.
6. This specification applies to the Pentium II processor system bus frequency of 66 MHz.
7. Due to the difficulty of accurately measuring clock jitter in a system, it is recommended that a clock driver be used that is designed to meet the period stability specification into a test load of 10 to 20 pF. This should be measured on the rising edges of adjacent BCLKs crossing 1.25 V at the processor core pin. The jitter present must be accounted for as a component of BCLK timing skew between devices.
8. The clock driver's closed loop jitter bandwidth must be set low to allow any PLL-based device to track the jitter created by the clock driver. The –20 dB attenuation point, as measured into a 10 to 20 pF load, should be less than 500 kHz. This specification may be ensured by design characterization and/or measured with a spectrum analyzer. See the *CKDM66-M Clock Synthesizer/Driver Specification* for further details.
9. Not 100% tested. Specified by design characterization as a clock driver requirement.

### 4.4.2.1 System Bus Clock (BCLK) Signal Quality Specifications and Measurement Guidelines

Table 17 describes the signal quality specifications at the processor core for the module system bus clock (BCLK) signal. Figure 3 describes the signal quality waveform for the system bus clock at the processor core pins.

**Table 17. BCLK Signal Quality Specifications for Simulation at the Processor Core**

T#	Parameter	Min	Nom	Max	Unit	Figure	Notes <sup>1</sup>
V1:	BCLK $V_{IL}$			0.5	V	3	
V2:	BCLK $V_{IH}$	1.765			V	3	2
V3:	$V_{IN}$ Absolute Voltage Range	-0.8		3.3	V	3	2
V4:	Rising Edge Ringback	1.765			V	3	3, 4
V5:	Falling Edge Ringback			0.5	V	3	4

**NOTES:**

1. Unless otherwise noted, all specifications in this table apply to all modules.
2. This is the Pentium II processor system bus clock overshoot and undershoot specification for 66-MHz system bus operation.
3. Clock signal must be monotonic from +0.5 V to +1.765 V.
4. The rising and falling edge ringback voltage specified is the minimum (rising) or maximum (falling) absolute voltage the BCLK signal can dip back to after passing the  $V_{IH}$  (rising) or  $V_{IL}$  (falling) voltage limits. This specification is an absolute value.

**Figure 3. BCLK, TCK, PICCLK Generic Clock Waveform at the Processor Core Pins**

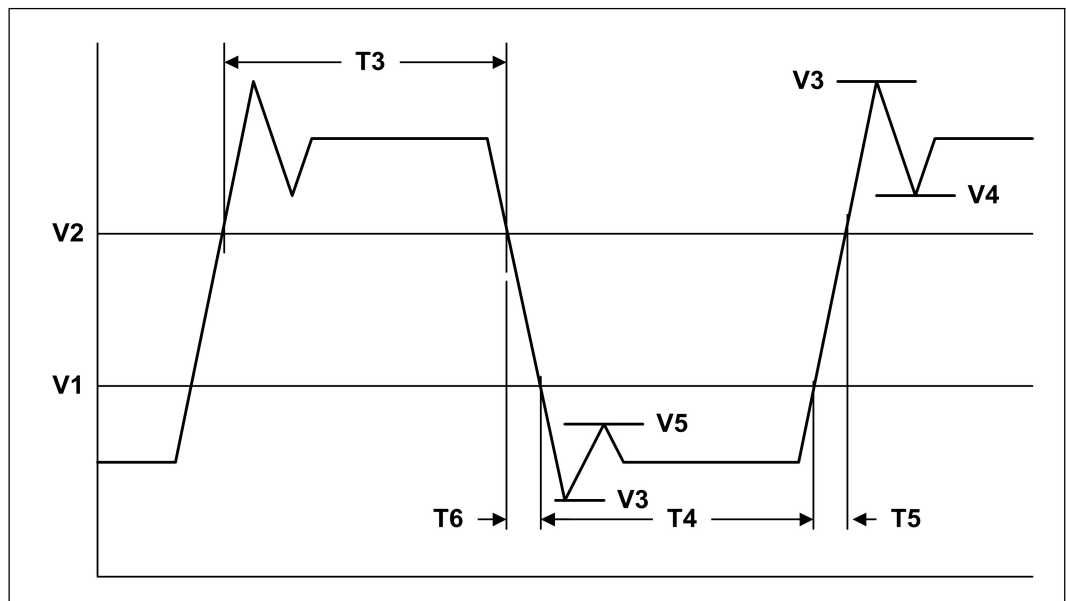

## 4.5 Module Signal Termination

System design requirements for signal termination for the module have been split between the processor module and the system electronics. The system designer is responsible for ensuring proper termination on the signals.

## 4.6 Processor Core Voltage Regulation

The module's DC voltage regulator (DC/DC converter) is designed to support the core voltage and I/O ring voltage for current and future processors. The DC voltage regulator provides the appropriate processor core voltage, the processor sideband signal pull-up voltage, and the I/O voltage for the components on the processor core backside bus. Of these voltages, only the processor sideband pull-up voltage (V\_CPUPU) is delivered to the system electronics.

The module supports an input DC voltage range of 5 V - 21 V from the system battery, or power supply.

### 4.6.1 Voltage Regulator Efficiency

There are three voltage regulators on the module. These voltage regulators generate the core voltage used by the CPU, the voltage for the backside bus, and the voltage for the CPU I/O ring voltage. The core voltage regulator provides the required current from the V\_DC (battery or A/C voltage adapter) supply. Its relative efficiencies are shown in Table 18. The backside bus I/O and CPU I/O ring voltage regulators tap the V\_3 plane and are about 85 percent efficient at typical loads.

**Table 18. Typical Voltage Regulator Efficiency**

I <sub>core</sub> , A <sup>3</sup>	V <sub>DC</sub> , V	I <sub>DC</sub> , A <sup>2</sup>	Efficiency <sup>1</sup>	V <sub>DC</sub> , V	I <sub>DC</sub> <sup>2</sup>	Efficiency <sup>1</sup>
1	5.00	0.394	83%	18.00	0.135	68%
2	5.00	0.752	88%	18.00	0.233	80%
3	5.00	1.212	82%	18.00	0.340	82%
4	5.00	1.506	88%	18.00	0.451	82%
5	5.00	1.921	86%	18.00	0.561	82%
6	5.00	2.290	86%	18.00	0.674	82%
7	5.00	2.683	85%	18.00	0.790	81%
1	12.00	0.186	74%	21.00	0.129	62%
2	12.00	0.335	83%	21.00	0.215	74%
3	12.00	0.491	85%	21.00	0.304	79%
4	12.00	0.652	85%	21.00	0.396	81%
5	12.00	0.816	85%	21.00	0.493	81%
6	12.00	0.980	84%	21.00	0.592	80%
7	12.00	1.149	83%	21.00	0.692	80%

**NOTES:**

1. These efficiencies will change with future voltage regulators that accommodate wider ranges of input voltages.
2. With V<sub>DC</sub> applied and the voltage regulator off, typical leakage is 0.3 mA with a maximum of 0.7 mA.
3. I<sub>core</sub> indicates the processor core current being drawn during test and measurement.

## 4.6.2 Voltage Regulator Control

The VR\_ON pin on the connector allows a digital signal (3.3 V, 5 V safe) to control the voltage regulator. The system manufacturer can use this signal to turn the module's voltage regulator on or off. VR\_ON should be controlled as a function of the same digital control signal (SUSB#) used to control the system's switched 5 V/3.3 V power planes. The PIIX4E Southbridge defines Suspend B as the power management state in which power is physically removed from the processor, L2 cache, 443BX Host Bridge/Controller, and voltage regulator. In this state, the SUSB# pin on the PIIX4E controls these power planes.

**Caution:** VR\_ON should switch high only when the following conditions are met;  $V_{5(s)} \geq 4.5$  V, and  $V_{DC} \geq 4.7$  V. Turning on VR\_ON prior to meeting these conditions will severely damage the module. See Figure 4 on page 30 for the proper timing sequencing.

### 4.6.2.1 Voltage Signal Definition and Sequencing

Table 19. Voltage Signal Definitions and Sequences

Signal	Source	Definitions and Sequences
V_DC	System Electronics	DC voltage driven from the power supply and is required to be between 5V and 21V DC. V_DC powers the module's DC-to-DC converter for processor core and I/O voltages. The module cannot be hot inserted or removed while V_DC is powered on.
V_3	System Electronics	V_3 is supplied by the system electronics for the 443BX.
V_5	System Electronics	V_5 is supplied by the system electronics for the 443BX's 5V reference voltage and module's voltage regulator.
V_3S	System Electronics	V_3S is supplied by the system electronics for the L2 cache devices. Each must be powered off during system STR and STD states.
VR_ON	System Electronics	Enables the module's voltage regulator circuit. When driven active high (3.3V) the voltage regulator circuit on the module is activated. The signal driving VR_ON should be a digital signal with a rise/fall time of less than or equal to 1 $\mu$ s.
V_CORE (also used as host bus GTL+ termination voltage VTT)	Module Only; not on module interface.	A result of VR_ON being asserted, V_CORE is an output of the DC-DC regulator on the module and is driven to the core voltage of the processor. It is also used as the host bus GTL+ termination voltage, known as VTT.
V_BSB_IO	Module Only; not on module interface.	V_BSB_IO is 1.8V. The system electronics uses this voltage to power the L2 cache-to-processor interface circuitry.
VR_PWRGD	Module	Upon sampling the voltage level of V_CORE for the processor, minus tolerances for ripple, VR_PWRGD is driven active high (3.3 V) for the system electronics to sample prior to providing PWROK to the PIIX4E. If VR_PWRGD is not sampled active within 1 second of the assertion of VR_ON the system electronics should deassert VR_ON.
V_CPUPU	Module	V_CPUPU is 2.5 V. The system electronics uses this voltage to power the PIIX4E-to-processor interface circuitry.
V_CLK	Module	V_CLK is 2.5 V. The system electronics uses this voltage to power the HCLK_(0:1) drivers for the processor clock.

Figure 4 details the sequencing of Signals and Voltage planes required for normal operation of the module.

The module provides the VR\_PWRGD signal, which indicates that the voltage regulator power is operating at a stable voltage level. The system manufacturer should use this signal on the system electronics to control power inputs and to gate PWROK to the PIIX4E Southbridge.

**Note:** The VR\_ON signal should be driven by a digital signal with a rise/fall time of less than or equal to 1  $\mu$ s and signaling voltage levels that meet the requirement of  $V_{il(max)}=0.4V$  and  $V_{ih(min)}=3.0V$ .

**Figure 4. Power On Sequence Timing**

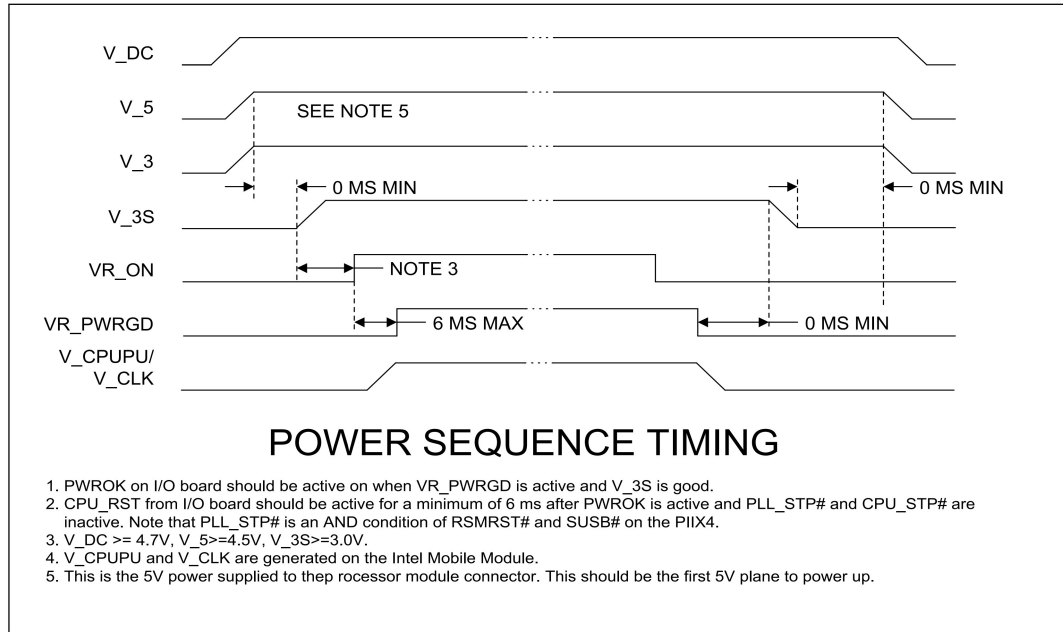

### 4.6.3 Power Planes: Bulk Capacitance Requirements

In order to provide adequate filtering and in-rush current protection for any system design, bulk capacitance is required. A small amount of bulk capacitance is supplied on the Module, however, in order to achieve proper filtering additional capacitance should be placed on the system electronics. Table 20 details the bulk capacitance requirements for the system electronics when using the Module.

**Table 20. Capacitance Requirement Per Power Plane**

Power Plane	Capacitance Requirements	ESR	Ripple Current	Rating
V_DC	100 $\mu$ F, 0.1 $\mu$ F, 0.01 $\mu$ F <sup>1</sup>	20 m $\Omega$	1-3.5 Amp <sup>3</sup>	20% tolerance @ 35 V
V_5	100 $\mu$ F, 0.1 $\mu$ F, 0.01 $\mu$ F <sup>1</sup>	100 m $\Omega$	1 Amp	20% tolerance @ 10 V
V_3	470 $\mu$ F, 0.1 $\mu$ F, 0.01 $\mu$ F <sup>1</sup>	100 m $\Omega$	1 Amp	20% tolerance @ 6 V
V_3S	100 $\mu$ F, 0.1 $\mu$ F, 0.01 $\mu$ F <sup>1</sup>	100 m $\Omega$	1 Amp	20% tolerance @ 6 V
VCC_AGP	22 $\mu$ F, 0.1 $\mu$ F, 0.01 $\mu$ F <sup>1</sup>	100 m $\Omega$	1 Amp	20% tolerance @ 6 V
V_CPUPU	2.2 $\mu$ F, 8200 pF <sup>2</sup>	n/a	n/a	20% tolerance @ 6 V
V_CLK	10 $\mu$ F, 8200 pF <sup>2</sup>	n/a	n/a	20% tolerance @ 6 V

**NOTES:**

1. Placement of above capacitance requirements should be located near the module connector.
2. V\_CLK filtering should be located next to the system clock synthesizer.
3. Ripple current specification depends on V\_DC input. For 5.0 V V\_DC, a 3.5 A device is required. For V\_DC at 18 V or higher, 1 A is sufficient.

### 4.6.3.1 V\_DC and V\_5 Decoupling

If V\_DC and V\_5 are tied together, ensure that decoupling guidelines are strictly followed to avoid noise from the V\_DC rail coupling to the V\_5 rail. Noise could trigger the undervoltage lockout circuits on the module. The example circuit shown in Figure 5 adheres to the decoupling guidelines.

Figure 5. V\_DC to V\_5 Decoupling Circuit Example

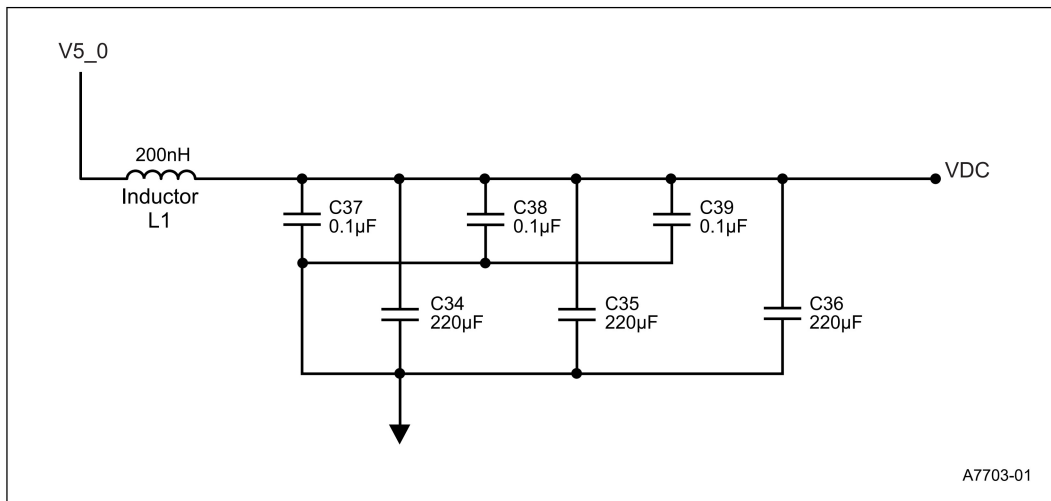

Exact component values are system dependant. Intel recommends that specific component values be determined through full simulation and parasitic modeling.

### 4.6.4 Surge Current Study

Surge current analysis was performed on a typical system power supply to determine the maximum amount of surge current that the module is capable of handling. This information was then used to develop the module system I/O bulk capacitance requirements (Table 20). This section provides the results of this study.

Figure 6 shows an electrical model used when analyzing instantaneous power-on conditions. The following analysis is provided as a worst case analysis. Depending on the system electronics design, different impedances may be seen yielding different results. The OEM should perform a thorough analysis to understand the implications of surge current on their system.

As previously stated, the following study was performed in a “worst-case” situation with no bulk capacitance on the V\_DC line on the system electronics. Given that, the module has two 4.7 µF with an ESR of 0.3 Ω each. The module connector is approximately 30 mΩ of series resistance for a total series resistance of 0.33 Ω. If the user powers the system with the A/C adapter (18 V), the amount of surge current seen by the capacitors on the module would be greater than 50 Amps! Figure 7 illustrates the results of this situation with a SPICE simulation.

Figure 6. Instantaneous In-Rush Current Model

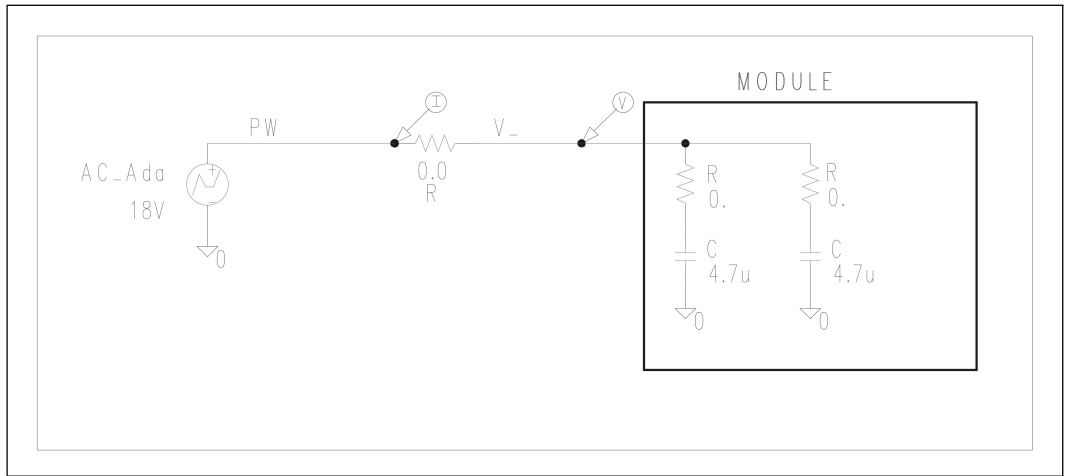
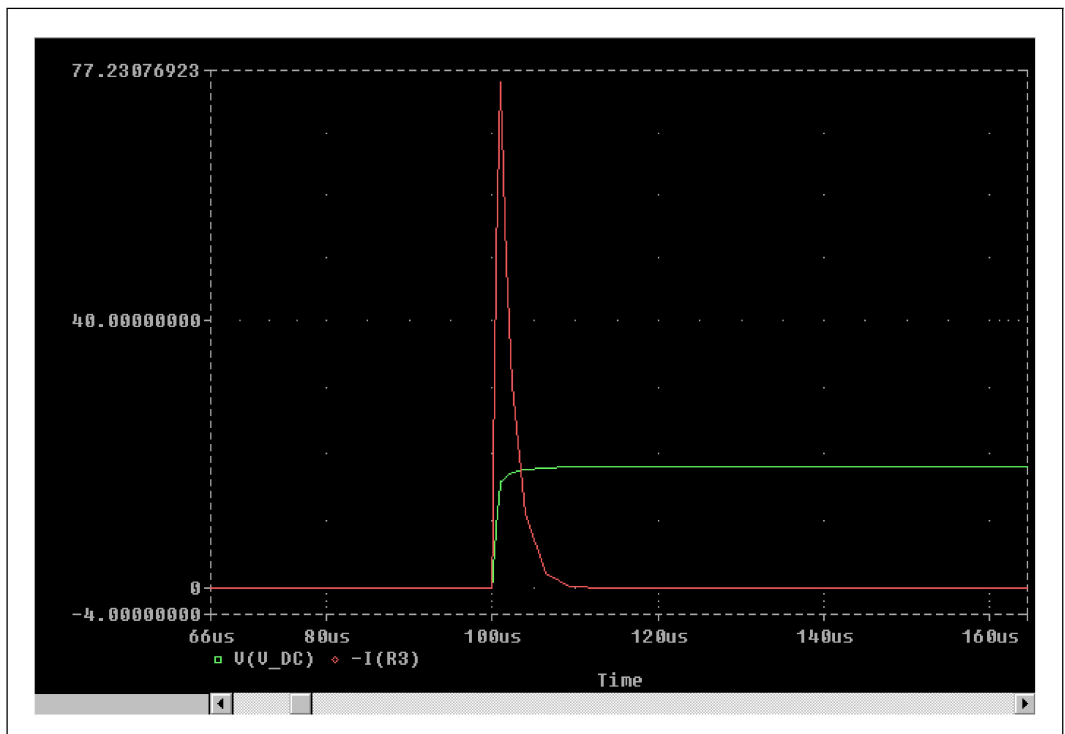
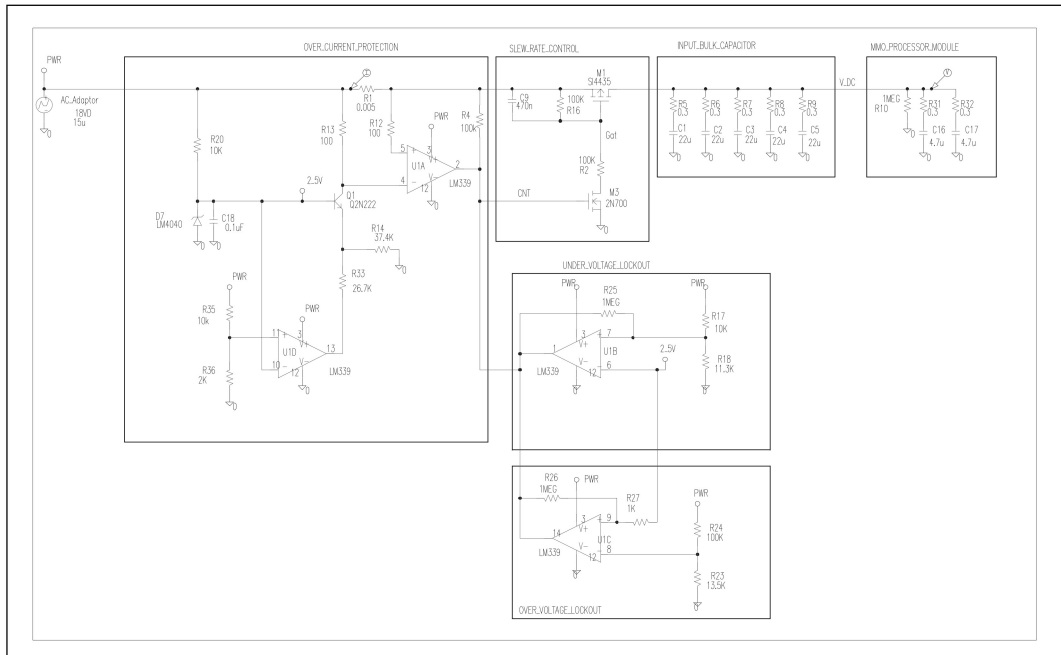

Figure 7. Instantaneous In-Rush Current



Due to the stringent component height requirements ( $\leq 4\text{mm}$ ) of the module, tantalum capacitors must be used as input bulk capacitance in the voltage regulator circuit. Because of tantalum capacitor's susceptibility to high in-rush current, special care must be taken to soften the initial rush of current applied to these capacitors. One way to soften the in-rush current and provide over voltage/over current protection is to ramp up V\_DC slowly using a circuit similar to the one shown in Figure 8.

Figure 8. Over Current Protection Circuit



#### 4.6.4.1 Slew-Rate Control: Circuit Description

In Figure 9, PWR is the voltage generated by applying the AC Adaptor or Battery. M1 is a low RDS(on) P-Channel MOSFET such as a Siliconix SI4435DY. When the voltage on PWR is applied and increased to over 4.75 V, the UNDER\_VOLTAGE\_LOCKOUT Circuit allows R4 to pull up the gate of M3 to start a turn-on sequence. M3 pulls its drain toward ground forcing current to flow through R2. M1 will not start to source any current until after t<sub>delay</sub> with t<sub>delay</sub> defined as:

$$t_{\text{delay}} := -R2 \cdot C9 \cdot \ln \left( 1 - \frac{V_t}{V_{\text{pwr}} - V_{\text{gs\_max}}} \right)$$

$$V_{\text{gs\_max}} = \frac{R16}{R16 + R2} \cdot V_{\text{pwr}}$$

The manufacturer’s V<sub>gs\_max</sub> specification of 20 V must never be exceeded. However, V<sub>gs\_max</sub> must be high enough to keep the RDS (on) of the device as low as possible. After the initial t<sub>delay</sub>, M1 will begin to source current and V<sub>DC</sub> will start to ramp up. The ramp up time, t<sub>ramp</sub>, is defined as:

$$t_{\text{ramp}} := -R2 \cdot C9 \cdot \ln \left( 1 - \frac{V_{\text{sat}}}{V_{\text{gs\_max}}} \right) - t_{\text{delay}}$$

Maximum current during the voltage ramping is:

$$I = C_{\text{total}} \frac{V_{\text{pwr}}}{t_{\text{ramp}}}$$

With the circuit shown in Figure 11, t<sub>delay</sub> = 5.53 ms, t<sub>tran</sub> = 14.0 ms and I<sub>max</sub> = 146 mA.

Figure 9 shows a SPICE simulation of the circuit in Figure 11.

To increase the reliability of Tantalum capacitors, use a slew rate control circuit described in Figure 8 and voltage-derate the capacitor about 50 percent. That is, for a maximum input voltage of 18 V, use a 35 V capacitor with low ESR with high ripple current capability.

On the base board, place five 22  $\mu$ F/35 V capacitors directly at the V<sub>DC</sub> pins of the processor module connector. An acceptable capacitor for this application would be the component from AVX: TPSE226K035R0300.

One more issue that must be raised here is that the Slew Rate Control circuit should be applied to every input power source to the system V<sub>DC</sub> to provide the most protection. If all power sources (i.e., battery or batteries, AC Adaptor, etc.) are OR'ed together at the PWR node, there is still a potential problem. For example, if a 3X3 Li-Ion battery pack is powering the system (12 V at PWR), and the AC Adaptor (18 V) is plugged into the system, it will immediately source current to the PWR node and V<sub>DC</sub> rapidly. This is because the Slew Rate Control is already ON. Therefore, the slew rate control must be applied to every input power source to provide the most protection.

Also shown in Figure 11 are under and over voltage and over-current protection circuits that can be used to increase the protection level for the module.

**Figure 9. Spice Simulation Using In Rush Protection**

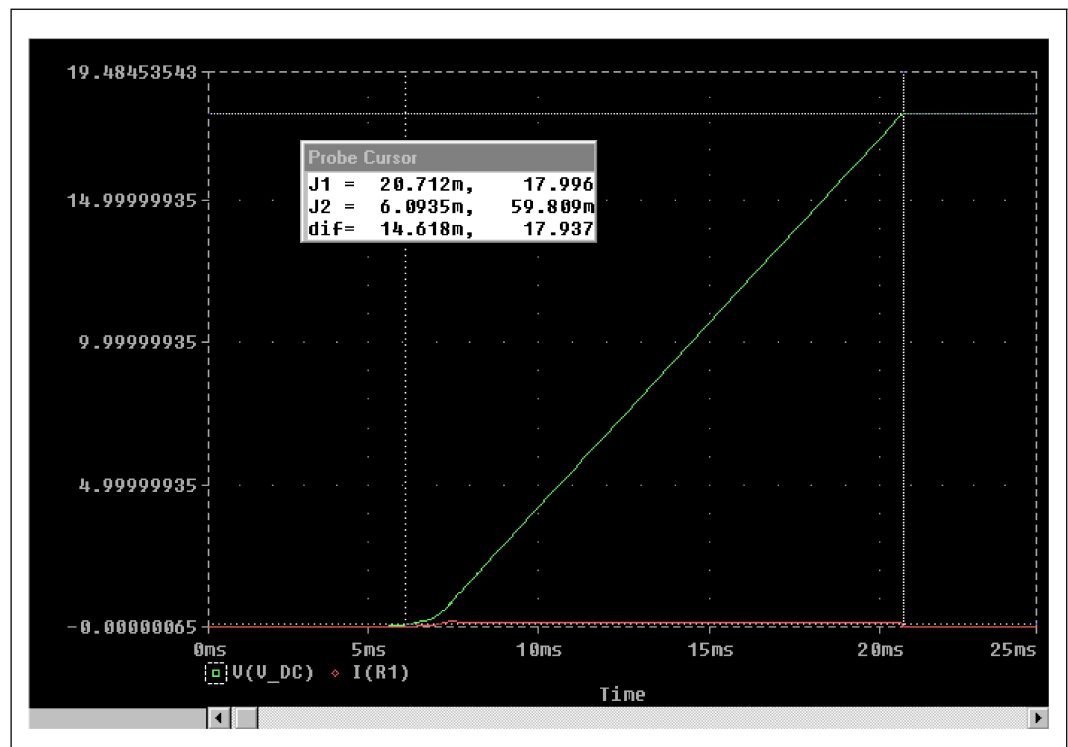

#### 4.6.4.2 Under-Voltage Lockout: Circuit Description

The circuit shown in Figure 9 provides an under-voltage protection and locks out the applied voltage to the module to prevent an accidental turn-on at low voltage. The output of this circuit, pin 1 of the LM339 comparator, is an open-collector output. It is low when the applied voltage at PWR is less than 4.75 V. This voltage can be calculated with the following equation with the voltage across D7 as 2.5 V. (D7 is a 2.5-V reference generator.)

$$V_{uv\_lockout} := V_{ref} \left[ 1 + \frac{R17}{\left( \frac{R18 \cdot R25}{R18 + R25} \right)} \right]$$

$$V_{uv\_lockout} = 4.757 \cdot \text{volt}$$

#### 4.6.4.3 Over Voltage Lockout: Circuit Description

The module is specified to operate with a maximum input voltage of 21 V. This circuit locks out the input voltage if it exceeds the maximum 21 V. The output of this circuit, Pin 14 of the LM339 comparator, is an open-collector output. It is low when the applied voltage at PWR is more than 21 V. This voltage can be calculated with the following equation:

$$V_{ov\_lockout} := V_{ref} \left( \frac{R26}{R26 + R27} \right) \cdot \left( 1 + \frac{R24}{R23} \right)$$

$$V_{ov\_lockout} = 20.998 \cdot \text{volt}$$

#### 4.6.4.4 Over Current Protection: Circuit Description

Figure 9 shows that the circuit detects an over-current condition and cuts off the input voltage applied to the module. This circuit has two different current limit trip points. This takes into account the different maximum current drain by the module at different input voltages (i.e., whether the AC Adaptor is plugged in or not.) Assuming the AC adapter voltage is 18 V and the battery is a 3x3 Li-Ion configuration with a minimum voltage of 7.5 V, the maximum current for the above circuit can be calculated using the following equation:

With AC Adaptor:

$$I_{wAdaptor} := \frac{V_{ref} - V_{be\_Q1}}{R14} \cdot \frac{R13}{R1}$$

$$I_{wAdaptor} = 0.989 \cdot \text{amp}$$

$$I_{woAdaptor} := \frac{V_{ref} - V_{be\_Q1}}{\left( \frac{R14 \cdot R33}{R14 + R33} \right)} \cdot \frac{R13}{R1}$$

$$I_{woAdaptor} = 2.375 \cdot \text{amp}$$

## 4.7 Active Thermal Feedback

Table 21 identifies the address allocated for the System Management Bus (SMBus) thermal sensor used on the module.

**Table 21. Thermal Sensor SMBUS Address**

Function	Fixed Address AD Bits (6:4)	Selectable Address AD Bits (3:0)
Thermal Sensor	100	1110
Reserved	010	1010
Reserved	010	1011

**NOTE:** The thermal sensor used is compliant with SMBus addressing. Please refer to the *Pentium® II processor Thermal Sensor Interface Specification*.

## 4.8 Power Management

### 4.8.1 Clock Control Architecture

The processor clock control architecture (Figure 10) has been optimized for leading edge deep green system designs. The Auto Halt state provides a low power clock state that can be controlled through the software execution of the HLT instruction. The Quick Start state provides a very low power, low exit latency clock state that can be used for hardware controlled “idle” computer states. The Deep Sleep state provides an extremely low power state that can be used for “Power-on Suspend” computer states, which is an alternative to shutting off the processor’s power. Compared to the Pentium processor exit latency of 1 ms, the exit latency of the Deep Sleep state has been reduced to 30 μs in the Pentium II processor – Low Power. The Stop Grant and Sleep states shown in Figure 10 are intended for use in “Deep Green” desktop and server systems—not in applied computing systems. Performing state transitions not shown in Figure 10 is neither recommended nor supported.

The clock control architecture consists of seven different clock states: Normal, Stop Grant, Auto Halt, Quick Start, HALT/Grant Snoop, Sleep and Deep Sleep states. The Stop Grant and Quick Start clock states are mutually exclusive, i.e., a strapping option on pin A15# chooses which state is entered when the STPCLK# signal is asserted. The Quick Start state is enabled by strapping the A15# pin to ground at Reset; otherwise, asserting the STPCLK# signal puts the processor into the Stop Grant state. The Stop Grant state has a higher power level than the Quick Start state and is designed for SMP platforms. The Quick Start state has a much lower power level, but it can only be used in uniprocessor platforms. Table 23 provides clock state characteristics (power numbers based on estimates for a Pentium II Processor – Low Power running at 266 MHz), which are described in detail in the following sections.

Figure 10. Pentium® II Processor – Low Power Clock Control States

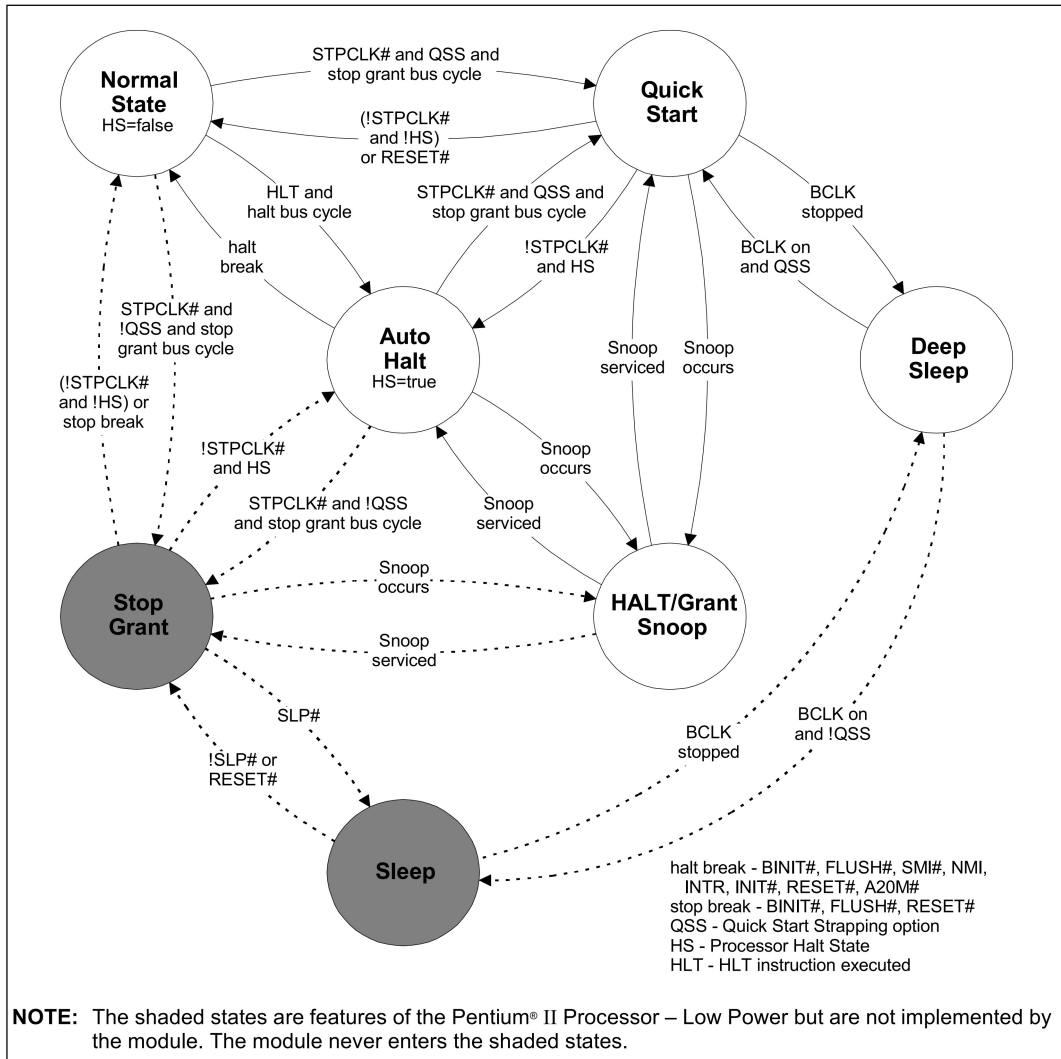

Table 22. Processor Clock State Characteristics

Clock State	Exit Latency	Power	Snooping?	System Uses
Normal	N/A	Varies	Yes	Normal program execution
Auto Halt	Approximately 10 bus clocks	1.2 W	Yes	S/W controlled entry idle mode
Stop Grant	10 bus clocks	1.2 W	Yes	H/W controlled entry/exit throttling
Quick Start	<b>Through snoop</b> , to HALT/Grant Snoop state: immediate <b>Through STPCLK#</b> , to Normal state: 10 bus clocks	0.5 W	Yes	H/W controlled entry/exit throttling
HALT/Grant Snoop	A few bus clocks after the end of snoop activity.	Not specified	Yes	Supports snooping in the low power states
Sleep	To <b>Stop Grant</b> state 10 bus clocks	0.5 W	No	H/W controlled entry/exit desktop idle mode support
Deep Sleep	30 $\mu$ s	100 mW	No	H/W controlled entry/exit powered-on suspend support

#### 4.8.2 Normal State

The Normal state of the processor is the normal operating mode where the processor’s internal clock is running and the processor is actively executing instructions.

#### 4.8.3 Auto Halt State

This is a low power mode entered by the processor through the execution of the HLT instruction. The power level of this mode is similar to the Stop Grant state. A transition to the Normal state is made by a halt break event (one of the following signals going active: NMI, INTR, BINIT#, INIT#, RESET#, FLUSH# or SMI#).

Asserting the STPCLK# signal while in the Auto Halt state causes the processor to transition to the Stop Grant or Quick Start state, where a Stop Grant Acknowledge bus cycle is issued. By deasserting STPCLK#, system logic can return the processor to the Auto Halt state without issuing a new Halt bus cycle.

The SMI# interrupt is recognized in the Auto Halt state. The return from the System Management Interrupt (SMI) handler can be to either the Normal state or the Auto Halt state. See the *Intel Architecture Software Developer’s Manual, Volume III: System Programmer’s Guide*, for more information. No Halt bus cycle is issued when returning to the Auto Halt state from SMM.

The FLUSH# signal is serviced in the Auto Halt state. After the on-chip and off-chip caches have been flushed, the processor will return to the Auto Halt state without issuing a Halt bus cycle. Transitions in the A20M# pin are recognized while in the Auto Halt state.

#### 4.8.4 Stop Grant State

The processor enters this mode with the assertion of the STPCLK# signal when it is configured for Stop Grant state (via the A15# strapping option). The processor is still able to respond to snoop requests and latch interrupts. Latched interrupts will be serviced when the processor returns to the Normal state. Only one occurrence of each interrupt event will be latched. A transition back to the Normal state can be made by the de-assertion of the STPCLK# signal, or the occurrence of a stop break event (a BINIT#, FLUSH# or RESET# assertion).

While in the Stop Grant state, SMI#, INIT# and LINT[1:0] will be latched by the processor, and only serviced when the processor returns to the normal state. Only one occurrence of each event will be recognized upon return to the normal state.

The processor will return to the Stop Grant state after the completion of a BINIT# bus initialization unless STPCLK# has been deasserted.

RESET# assertion will cause the processor to immediately initialize itself, but the processor will stay in the Stop Grant state after initialization until STPCLK# is deasserted.

If the FLUSH# signal is asserted, the processor will flush the on-chip and off-chip caches and return to the Stop Grant state. A transition to the Sleep state can be made by the assertion of the SLP# signal.

##### 4.8.4.1 Quick Start State

This is a mode entered by the processor with the assertion of the STPCLK# signal when it is configured for the Quick Start state (via the A15# strapping option). In the Quick Start state the processor is only capable of acting on snoop transactions generated by the system bus priority device. Because of its snooping behavior, Quick Start can only be used in a Uniprocessor (UP) configuration.

A transition to the Deep Sleep state can be made by stopping the clock input to the processor. A transition back to the Normal state (from the Quick Start state) is made only if the STPCLK# signal is deasserted.

While in this state the processor is limited in its ability to respond to input. It is incapable of latching any interrupt, servicing snoop transactions from symmetric bus masters or responding to FLUSH# or BINIT# assertions. While the processor is in the Quick Start state, it will not respond properly to any input signal other than STPCLK#, RESET# or BPRI#. If any other input signal changes, then the behavior of the processor will be unpredictable. No serial interrupt messages may begin or be in progress while the processor is in the Quick Start state. The thermal sensor will respond normally to SMBus transactions when the processor is in the Quick Start state.

RESET# assertion will cause the processor to immediately initialize itself, but the processor will stay in the Quick Start state after initialization until STPCLK# is deasserted.

Asserting the SLP# signal when the processor is configured for Quick Start will result in unpredictable behavior and is not recommended.

#### 4.8.5 HALT/GRANT Snoop State

The processor will respond to snoop transactions on the system bus while in the Auto Halt, Stop Grant or Quick Start state. When a snoop transaction is presented on the system bus the processor will enter the HALT/GRANT Snoop state. The processor will remain in this state until the snoop on the system bus has been serviced and the system bus is quiet. After the snoop has been serviced, the processor will return to the previous Auto Halt, Stop Grant or Quick Start state. If the HALT/Grant Snoop state is entered from the Quick Start state, then the input signal restrictions of the Quick Start state still apply in the HALT/Grant Snoop state, except for those signal transitions that are required to perform the snoop.

#### 4.8.6 Sleep State

The Sleep state is a very low power state in which the processor maintains its context and the phase-locked loop (PLL) maintains phase lock. The Sleep state can only be entered from the Stop Grant state. After entering the Stop Grant state, the SLP# signal can be asserted, causing the processor to enter the Sleep state. The SLP# pin is not recognized in the Normal or Auto Halt states.

The processor can be reset by the RESET# pin while in the Sleep state. If RESET# is driven active while the processor is in the Sleep state then SLP# and STPCLK# must immediately be driven inactive to ensure that the processor correctly executes the Reset sequence.

Input signals (other than RESET#) may not change while the processor is in the Sleep state or transitioning into or out of the Sleep state. Input signal changes at these times will cause unpredictable behavior. Thus, the processor is incapable of snooping or latching any events in the Sleep state. The thermal sensor will respond normally to SMBus transactions when the processor is in the Sleep state.

While in the Sleep state, the processor is capable of entering its lowest power state, the Deep Sleep state, by removing the processor's input clock. PICCLK may be removed in the Sleep state.

#### 4.8.7 Deep Sleep State

The Deep Sleep state is the lowest power mode the processor can enter while maintaining its context. The Deep Sleep state is entered by stopping the BCLK input to the processor, while it is in the Sleep or Quick Start state. For proper operation, the BCLK input should be stopped in the low state.

To re-enter either the Sleep or Quick Start state from the Deep Sleep state, the BCLK input must be restarted. The processor will return to the Sleep or Quick Start state, as appropriate, after 30 ms. PICCLK may be removed in the Deep Sleep state. PICCLK should be designed to turn on when BCLK turns on when transitioning out of the Deep Sleep state.

The input signal restrictions for the Deep Sleep state are the same as for the Sleep state, except that RESET# assertion will result in unpredictable behavior. The thermal sensor will respond normally to SMBus transactions when the processor is in the Deep Sleep state.

#### 4.8.8 Currently Supported Clock States

Table 23 shows the low-power clock states supported by the Pentium II processor family product line.

**Table 23. Low-Power Clock States Supported by Processor**

Processor	Clock State				
	Stop Grant	Auto Halt	Quick Start	Sleep	Deep Sleep
Pentium® Pro Processor	x	x			
Pentium II Processor	x	x		x	x
Pentium II Processor – Low Power	x	x	x	x	x
Pentium II Processor – Low-Power Module		x	x		x

#### 4.8.9 Operating System Implications of the Quick Start and Sleep States

There are a number of architectural features of the Pentium II Processor – Low Power that are not available when the Quick Start state is enabled or do not function in the Quick Start or Sleep state as they do in the Stop Grant state. These features are part of the APIC, time-stamp counter and performance monitor counters.

The local APIC timer does not behave properly when the processor is in the Quick Start or Sleep state. There is no guarantee that the local APIC timer will count down in the Quick Start or Sleep state. If the timer counts down to zero when the processor is in or about to enter the Quick Start or Sleep state, the processor's behavior will be unpredictable. Inter-Processor Interrupts (IPIs) should not be used in Pentium II processor – Low Power systems. If software generates an IPI just before the processor enters the Quick Start or Sleep state, then a message on the APIC bus will be generated. This would violate the requirement that no input signals toggle in the Quick Start or Sleep state. Any software-generated IPI in a Pentium II Processor – Low Power system (uniprocessor system) will always result in an error.

The time-stamp counter and the performance monitor counters are not guaranteed to count in the Quick Start or Sleep states. If software sets the APIC interrupt enable bit of either of the performance counters, then the resulting behavior will be unpredictable.

### 4.9 Typical POS/STR Power

The Module supports both power on suspend (POS) and suspend to RAM (STR) features. Typical power during these states are:

State	Module Power
POS	910mW
STR	3mW

These are average values of measurement on several typical modules and are guidelines only.

## 5.0 Mechanical Requirements

### 5.1 Module Dimensions

This section provides the physical dimensions for the module.

#### 5.1.1 Board Area

Figure 11 shows the board dimensions and the connector orientation for the module.

Figure 11. Low-Power Module Board Dimensions

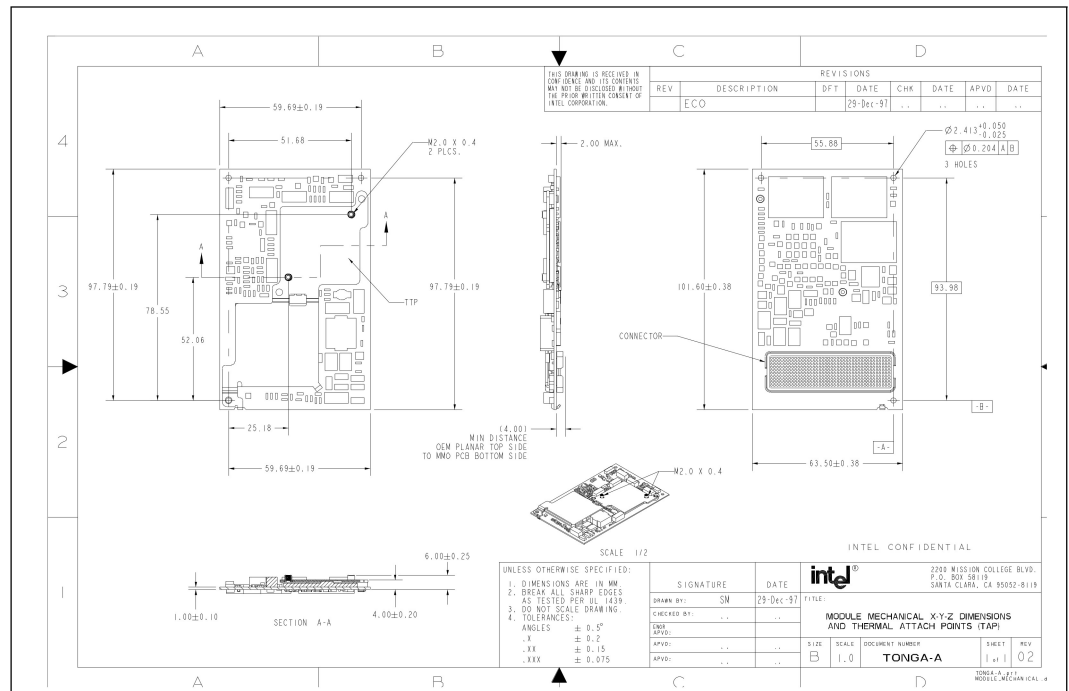

### 5.1.2 Module Pin 1 Location

Figure 12 shows the location of pin 1 of the 400-pin connector as referenced to the adjacent mounting hole.

**Figure 12. Low-Power Module Board Dimensions— Connector Pin 1 Orientation**

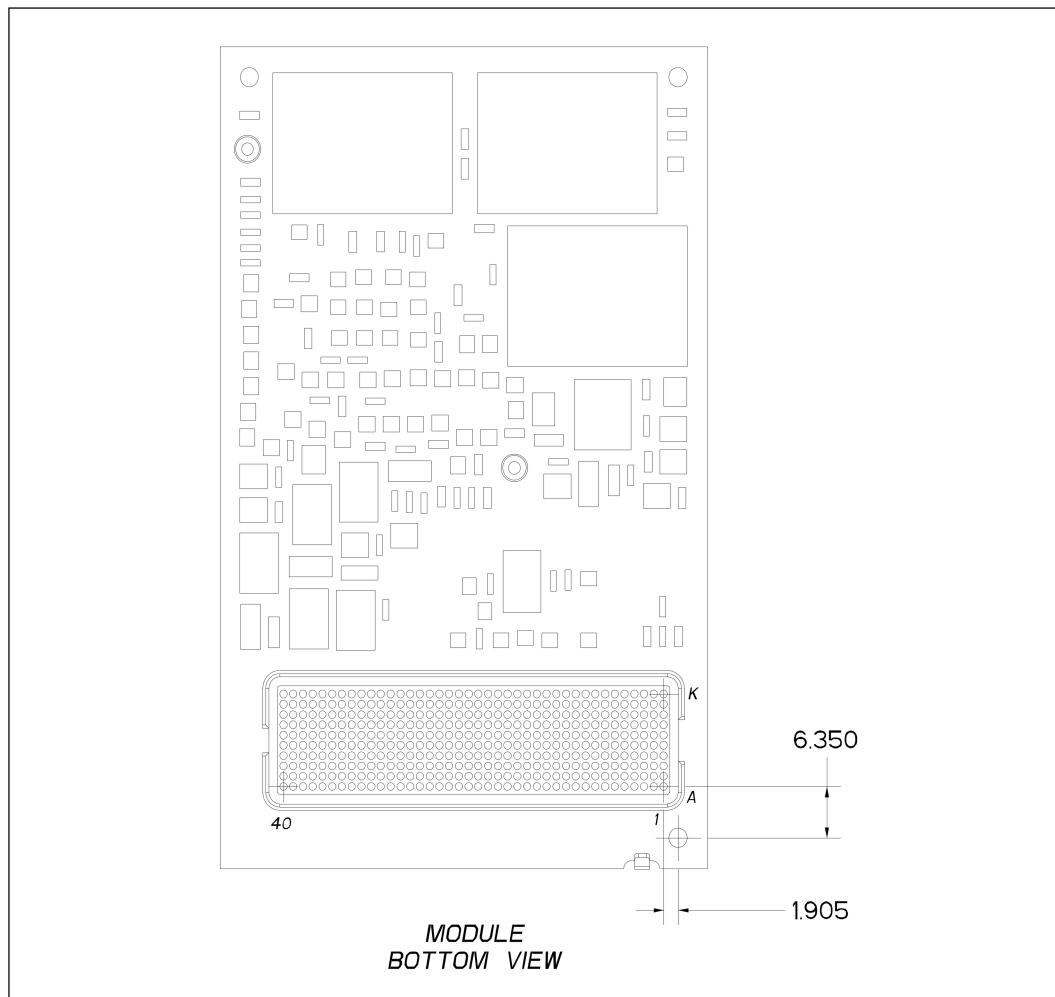

**Figure 13. PCB Board Thickness**

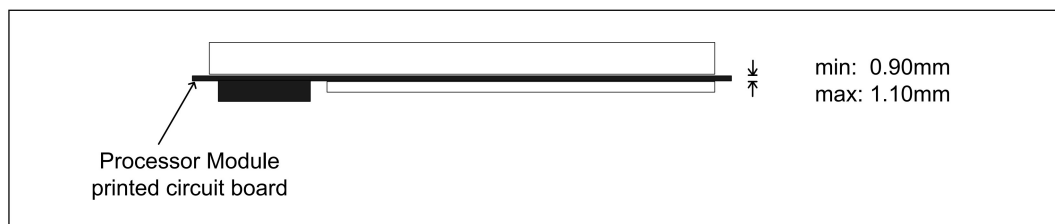

### 5.1.3 Printed Circuit Board Thickness

Figure 13 shows the module profile and the associated minimum and maximum thickness of the printed circuit board (PCB). The range of PCB thickness allows for different PCB technologies to be used with current and future modules.

**Note:** The system manufacturer must ensure that the mechanical restraining method and/or system-level EMI contacts are able to support this range of PCB thickness, to ensure compatibility with future modules.

### 5.1.4 Height Restrictions

Figure 14 shows the module mechanical stackup and associated component clearance requirements.

The system manufacturer establishes the board-to-board clearance between the module and the system electronics by selecting one of three possible mating connectors.

The mating connectors provide board-to-board clearances (distance underneath the module) of 4 mm, 6 mm or 8 mm. With these three options, the system manufacturer has reasonable flexibility in choosing components on the system electronics that are between the two boards. The connector receptacles are available from Berg Electronics (part number 74219-002).

**Figure 14. Module Mechanical Drawing**

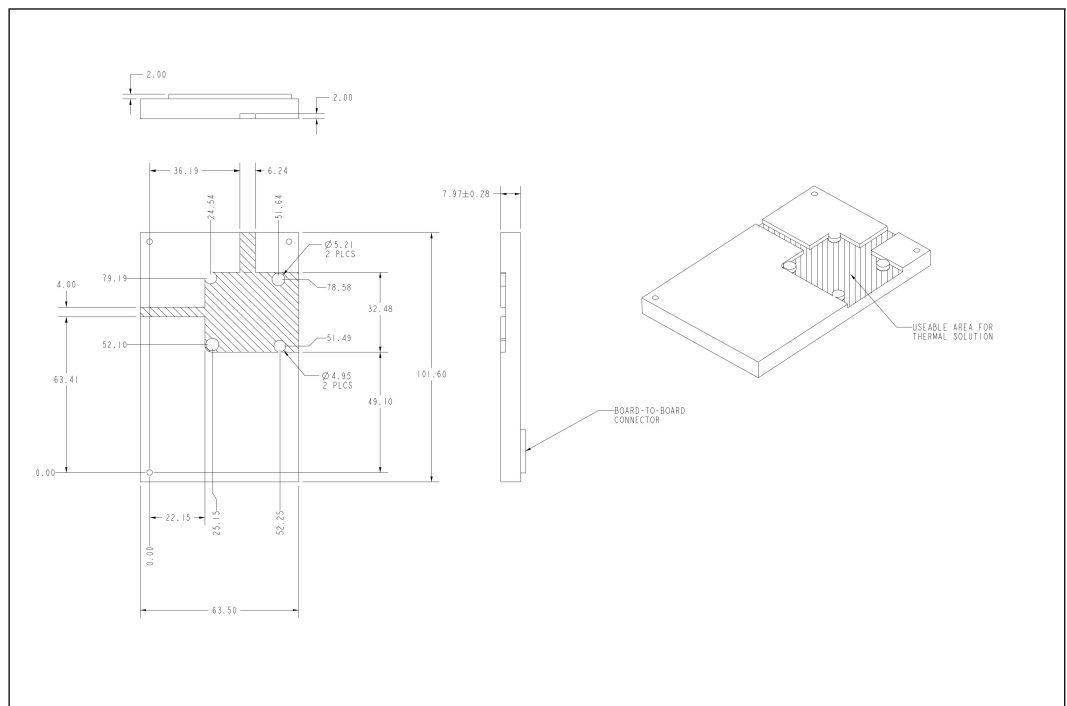

**Note:** The module top side component clearance is referenced from the bottom of the PCB, so it is independent of the PCB thickness.

## 5.2 Thermal Transfer Plate

The module provides a thermal transfer plate, or TTP, connected to the processor in a standard position called the thermal attach point (see Figure 15 and Figure 16 for exact dimensions). The thermal attach point is a fixed location relative to the mounting holes and other physical datum on the module. The system manufacturer can use both a heat pipe and a heat spreader plate in contact with the thermal attach point to transfer heat through the system or a thermal solution of their choice. The TTP thermal resistance as measured between the processor core to the top of the TTP is less than 1° C per Watt.

The thermal transfer plate is physically mounted to the module, and may be different from one generation of module to the next. The following figures detail the mechanical dimensions of the thermal transfer plate used on the module, and the conceptual relationship between the circuit board thermal transfer plate, and thermal attach point.

Figure 15. Thermal Transfer Plate

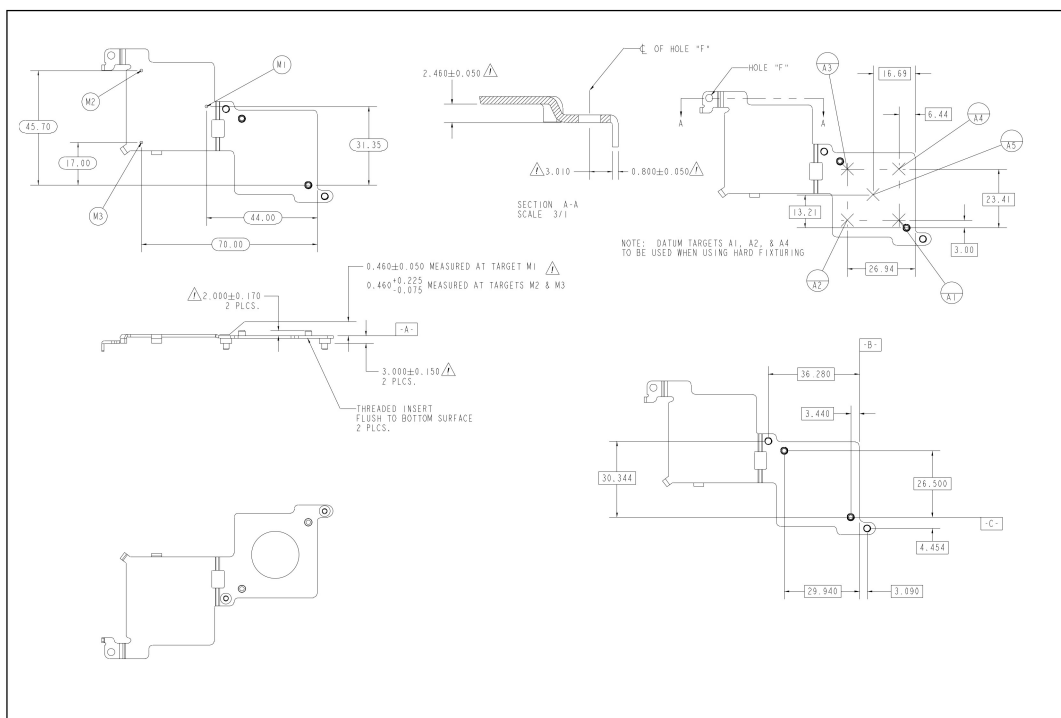
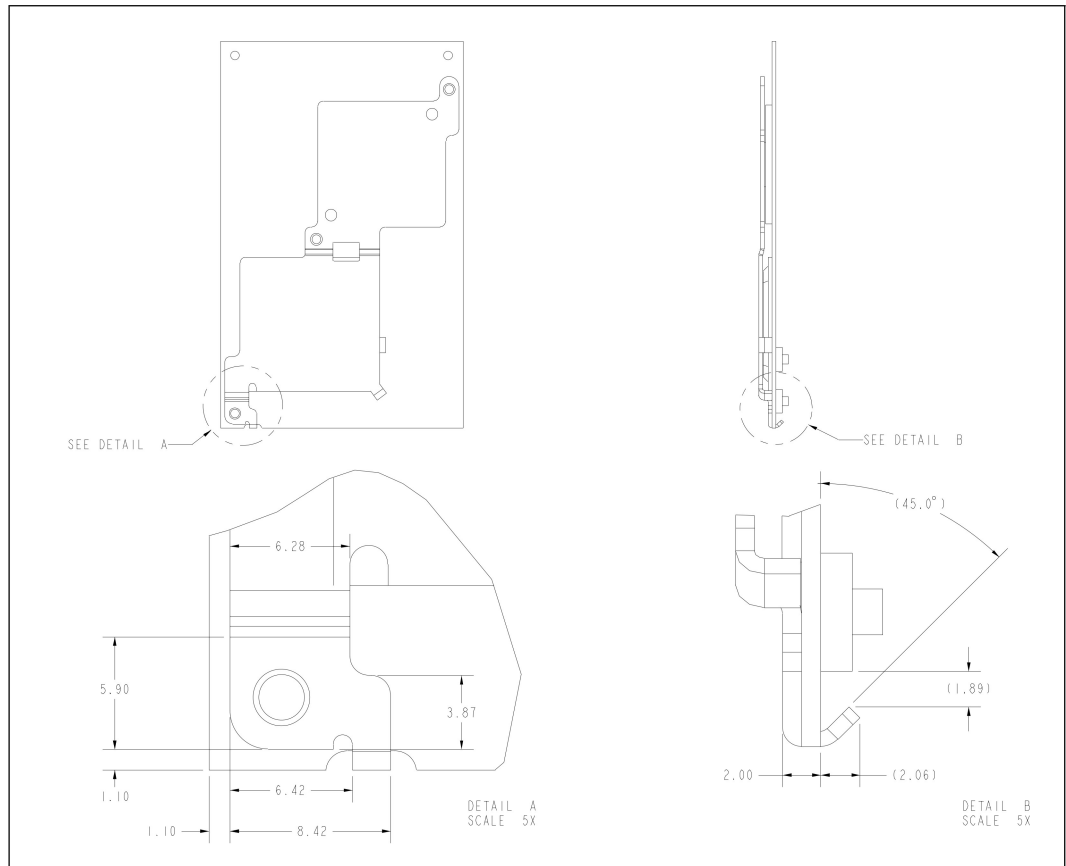

Figure 16. Thermal Transfer Plate



## 5.3 Module Physical Support

Figure 17 shows the module standoff support hole patterns and the board edge clearance around the perimeter of the module. These hole locations and board edge clearances will remain fixed for all modules. The hole patterns and board edge clearance lets the system manufacturer develop several methods for mechanically supporting the module within a system.

### 5.3.1 Module Mounting Requirements

Three mounting holes are available to the System OEM for securing the module to the system base or the system electronics. See Figure 11 for mounting hole locations. It is strongly recommended that the designer use mounting screws through all three of the mounting holes to ensure long term reliability of the mechanical and EMI integrity of the system.

To interface to the module's thermal transfer plate (TTP), it is recommended that the exact dimensions shown in Figure 15 for the OEM thermal interface block be used. These dimensions provide maximum contact area to the TTP while ensuring that no warpage of the TTP occurs. If warpage occurs due to the use of an improperly-designed interface, or over-tightening of assembly screws, the thermal resistance of the module could be adversely affected.

When attaching the mating block to the module TTP, material such as a thermal elastomer or thermal grease should be used. This material is designed to reduce the thermal resistance and should be placed between the TTP and the OEM mating block. This will improve the overall system thermal efficiency.

After the OEM has placed the mating thermal transfer plate, it should be secured with 2.0 mm screws using a maximum torque of 1.5 - 2.0 Kg\*cm (equivalent to 0.147 - 0.197 N\*m). The thread length of the 2.00 mm screws should be 2.25 mm gaugeable thread (2.25 mm minimum to 2.80 mm maximum).

The board edge clearance includes a 0.762 mm (0.030 in) width EMI containment ring around the perimeter of the module. This ring is on each layer of the module PCB and is grounded. On the surface of the module, the metal is exposed for EMI shielding purposes. The hole patterns placed on the module also have a plated surrounding ring and one can use a metal standoff to contact the ring for EMI shielding purposes. Figure 17 shows the dimensions of the EMI containment ring and the keepout area. No components are placed on the board in the keepout area.

**Figure 17. Standoff Holes, Board Edge Clearance and EMI Containment Ring**

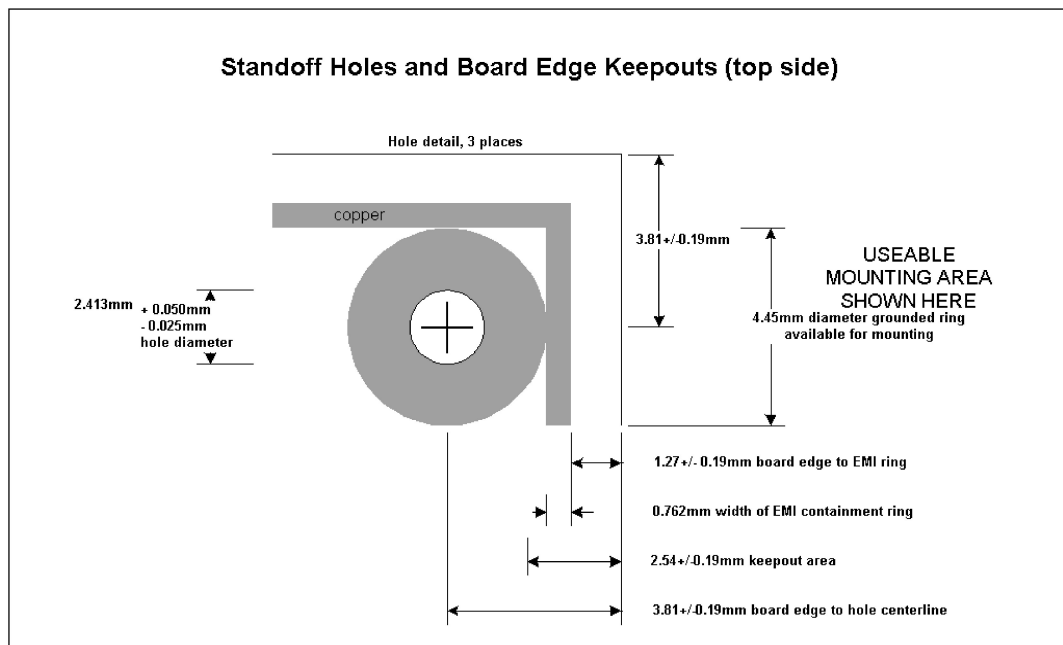

Standoffs should be used to provide support for the installed module. The distance from the bottom of the module PCB to the top of the OEM system electronics board with the connectors mated is 4.0 mm +0.16 mm / -0.13 mm, however the warpage of the baseboard can vary and should be calculated into the final dimensions of the standoffs used.

**5.3.1.1 Module Weight**

The weight of the module is 48 g +/- 2 g.

## 6.0 Thermal Specifications

Table 24. Low-Power Module Power Specifications

Symbol	Parameter	Typ	Max <sup>1</sup>	Unit	Notes
TDP	Thermal Design Power at 266 MHz	—	13.9	W	Module (core, Northbridge, voltage regulator, & L2 cache)

**NOTES:**

1. TDP<sub>MAX</sub> is a specification of the total power dissipation of the worst-case processor, worst-case Northbridge, worst-case L2 cache, and worst-case voltage regulator while executing a worst-case instruction mix under normal operating conditions at nominal voltages. Not 100% tested. Specified by design/characterization.

## 7.0 Labeling Information

The module has two means of being tracked. The first means is by labeling information via the Intel Product Tracking Code (PTC) and the other is by an OEM generated software utility.

### 7.1 Product Tracking Code

The Product Tracking Code label provides module information that is used by Intel to determine the assembly level of the module. The PTC label exists on the secondary side of the module and provides the following information:

Figure 18. Module Product Tracking Information

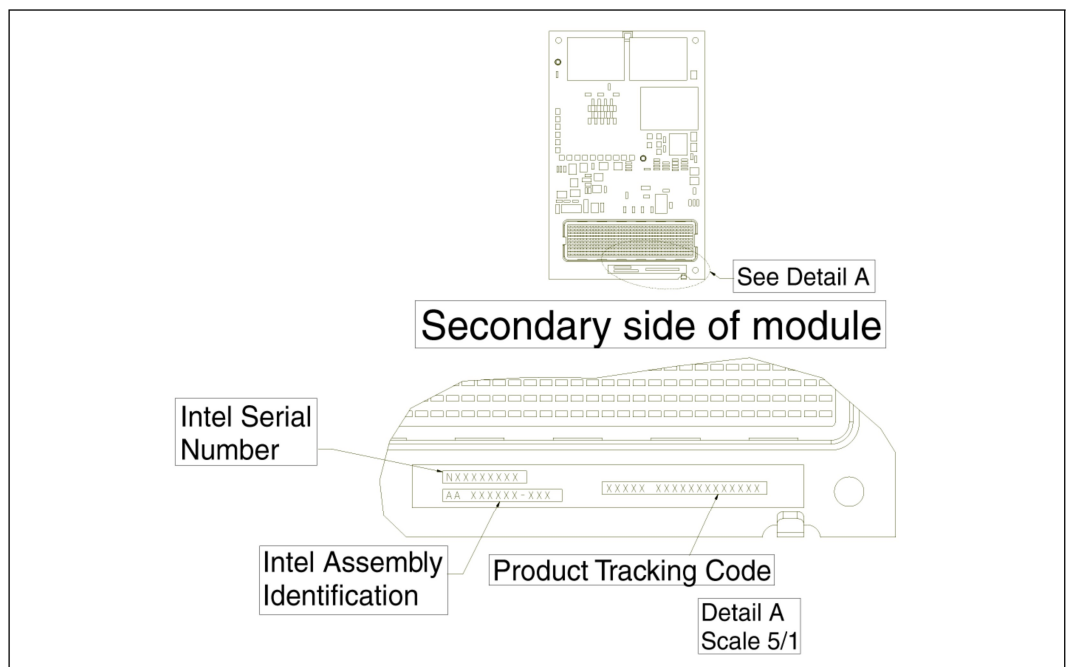

Thirteen letters make up the Product Tracking Code. An example and a definition of each element of the tracking code is shown below.

Example: **PME26605001AA**

The format is **AABCCCDDEEEFF**.

Tracking Code	Definition
AA	PM - processor module
B	E - Pentium® II Processor – Low Power
CCC	266 - Processor speed
DD	05 - Cache size, 512 Kbyte
EEE	Design Revision (starts at 001)
FF	Processor Revision (starts at AA)

### 7.1.1 Module Identification Bits

Located on the module are four strapping resistors used to determine the production level of the module. If connected and terminated properly, up to 16 unique module revision levels can be determined. Using a software utility generated by the OEM, these ID bits can be read along with the processor and Northbridge stepping IDs to provide a complete module manufacturing revision level.

## 8.0 Environmental Standards

The environmental standards the module are defined in Table 25.

**Table 25. Environmental Standards**

Parameter	Condition	Specification
Temperature Cycle	Non-Operating	-40° C to 85° C
	Operating	0° C to 55° C
Humidity	Unbiased	85% relative humidity at 55° C
Voltage	V_5	+/- 4%
	V_3S	+/- 4%
	V_3	+/- 4%
Shock	Non-Operating	Half Sine, 2 G, 11 ms
	Unpackaged	Trapezoidal, 50 G, 11 ms
	Packaged	Inclined Impact at 5.7 ft/s
	Packaged	Half Sine, 2 ms at 36" Simulated Free Fall
Vibration	Unpackaged	5 Hz to 500 Hz 2.2 gRMS random
	Packaged	10 Hz to 500 Hz 1.0 gRMS
	Packaged	11,800 impacts 2 Hz to 5 Hz (low frequency)
ESD	Human Body Model	0 to 2 kV (no detectable err)