



# e.MMC Memory

## MTFC8GAC, MTFC16GAK, MTFC32GAK, MTFC64GAJ, MTFC128GAJ

### Features

- MultiMediaCard (MMC) controller and NAND Flash
- JEDEC/MMC standard version 5.0-compliant (JEDEC Standard No. JESD84-B50)<sup>1</sup>
  - V<sub>CC</sub>: 2.7–3.6V
  - V<sub>CCQ</sub> (dual voltage): 1.70–1.95V; 2.7–3.6V
    - Advanced 12-signal interface
    - ×1, ×4, and ×8 I/Os, selectable by host
    - SDR/DDR modes up to 52 MHz clock speed
    - HS200/HS400 mode
    - Command classes: class 0 (basic); class 2 (block read); class 4 (block write); class 5 (erase); class 6 (write protection); class 7 (lock card)
    - Temporary write protection
    - Boot operation (high-speed boot)
    - Sleep mode
    - Replay-protected memory block (RPMB)
    - Hardware reset signal
    - Multiple partitions with enhanced attribute
    - Permanent and power-on write protection
    - High-priority interrupt (HPI)
    - Data strobe pin
    - Field firmware update (FFU)
    - Device health report
    - Sleep notification
    - Background operation
    - Reliable write
    - Discard and sanitize
    - Power-off notification feature
    - Backward compatible with previous MMC
    - ECC and block management implemented

### Options

- Density
  - 8GB
  - 16GB
  - 32GB
  - 64GB
  - 128GB
- NAND component
  - 32Gb
  - 64Gb
  - 128Gb
- Controller
- Packages – JEDEC-standard, RoHS-compliant
  - 153-ball TFBGA
  - 153-ball VFBGA
  - 153-ball VFBGA
  - 169-ball LFBGA
  - 169-ball LFBGA
- Operating temperature range
  - From –40°C to +85°C
  - From –40°C to +105°C
- Special character

### Marking

8G
16G
32G
64G
128G
AC
AK
AJ
AE
NS
CN
JP
DN
CE
AIT
AAT
5M

Note: 1. The JEDEC specification is available at [www.jedec.org/sites/default/files/docs/JESD84-B50.pdf](http://www.jedec.org/sites/default/files/docs/JESD84-B50.pdf).



### Part Numbering Information

Micron® e.MMC memory devices are available in different configurations and densities.

**Note:** The diesis symbol (‡) on the part numbers indicate "Preliminary" with the following legal disclaimer:

‡Products and specifications discussed herein are for evaluation and reference purposes only and are subject to change by Micron without notice. Products are only warranted by Micron to meet Micron’s production data sheet specifications.

**Figure 1: e.MMC Part Numbering**

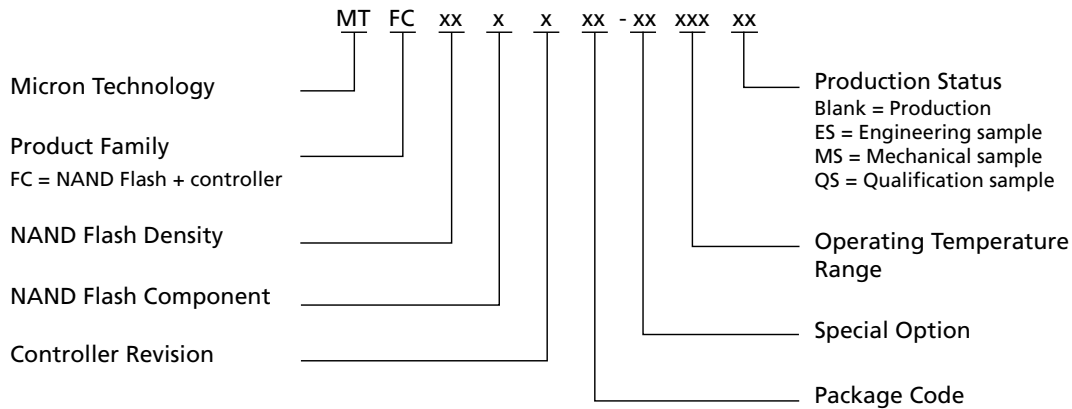

**Table 1: Ordering Information**

Base Part Number	Density	Package	Shipping
MTFC8GACAENS-5M AIT MTFC8GACAENS-5M AAT	8GB	153-ball TFBGA 11.5mm × 13mm × 1.2mm	Tray Tape and reel
MTFC16GAKAECN-5M AIT MTFC16GAKAEJP-5M AIT	16GB	153-ball VFBGA 11.5mm × 13mm × 1.0mm	Tray Tape and reel
MTFC32GAKAECN-5M AIT MTFC32GAKAEJP-5M AIT	32GB	153-ball VFBGA 11.5mm × 13mm × 1.0mm	Tray Tape and reel
MTFC64GAJAEDN-5M AIT MTFC64GAJAECE-5M AIT MTFC64GAJAECE-5M AAT	64GB	169-ball LFBGA 14mm × 18mm × 1.4mm	Tray Tape and reel
MTFC128GAJAECE-5M AIT MTFC128GAJAECE-5M AAT	128GB	169-ball LFBGA 14mm × 18mm × 1.4mm	Tray Tape and reel

### Device Marking

Due to the size of the package, the Micron-standard part number is not printed on the top of the device. Instead, an abbreviated device mark consisting of a 5-digit alphanumeric code is used. The abbreviated device marks are cross-referenced to the Micron part numbers at the FBGA Part Marking Decoder site: [www.micron.com/decoder](http://www.micron.com/decoder).



## e.MMC Performance

Performance in the following tables are retrieved with these conditions: Bus in  $\times 8$  I/O. Temperature 25°C. Sequential access of 2MB chunk, cache on (write). Additional performance data, such as system performance on a specific application board, will be provided in a separate document upon customer request. Typical values are measured on AIT device. In AAT device, beyond 85°C, a derating is possible.

**Table 2: HS400 Performance**

Condition	Typical Values					Unit
	8GB	16GB	32GB	64GB	128GB	
Sequential write	25	45	90	90	90	MB/s
Sequential read	230	270	270	270	270	MB/s

**Table 3: HS200 Performance**

Condition	Typical Values					Unit
	8GB	16GB	32GB	64GB	128GB	
Sequential write	25	45	80	80	80	MB/s
Sequential read	180	180	180	180	180	MB/s

**Table 4: DDR52 Performance**

Condition	Typical Values					Unit
	8GB	16GB	32GB	64GB	128GB	
Sequential write	25	45	75	75	75	MB/s
Sequential read	85	85	85	85	85	MB/s



## e.MMC Current Consumption

Current consumption in the following tables are retrieved with these conditions: Bus in  $\times 8$  I/O.  $V_{CC} = 3.6V$  and  $V_{CCQ} = 1.95V$ . Temperature  $25^{\circ}C$ . Measurements done as average RMS current consumption.  $I_{CCQ}$  in READ operation measurements with tester load disconnected.

**Table 5: HS400 Current Consumption**

Condition	Typical Values ( $I_{CC}/I_{CCQ}$ )				Unit
	8GB	16GB	32GB	64/128GB	
Write	110/30	120/30	160/30	200/30	mA
Read	140/60	150/60	150/60	170/60	mA
Sleep	0/110	0/110	0/110	0/170	$\mu A$
Auto-standby	40/110	50/120	60/110	70/170	$\mu A$

**Table 6: HS200 Current Consumption**

Condition	Typical Values ( $I_{CC}/I_{CCQ}$ )				Unit
	8GB	16GB	32GB	64/128GB	
Write	110/30	120/30	160/30	200/30	mA
Read	120/50	130/60	130/60	130/60	mA
Sleep	0/110	0/110	0/110	0/170	$\mu A$
Auto-standby	40/110	50/110	60/110	70/170	$\mu A$

**Table 7: DDR52 Current Consumption**

Condition	Typical Values ( $I_{CC}/I_{CCQ}$ )				Unit
	8GB	16GB	32GB	64/128GB	
Write	80/30	120/30	130/30	160/30	mA
Read	75/40	80/40	80/40	80/40	mA
Sleep	0/110	0/110	0/110	0/170	$\mu A$
Auto-standby	40/110	50/110	60/110	70/170	$\mu A$



## Important Notes and Warnings

Micron Technology, Inc. ("Micron") reserves the right to make changes to information published in this document, including without limitation specifications and product descriptions. This document supersedes and replaces all information supplied prior to the publication hereof. You may not rely on any information set forth in this document if you obtain the product described herein from any unauthorized distributor or other source not authorized by Micron.

**Automotive Applications.** Products are not designed or intended for use in automotive applications unless specifically designated by Micron as automotive-grade by their respective data sheets. Distributor and customer/distributor shall assume the sole risk and liability for and shall indemnify and hold Micron harmless against all claims, costs, damages, and expenses and reasonable attorneys' fees arising out of, directly or indirectly, any claim of product liability, personal injury, death, or property damage resulting directly or indirectly from any use of non-automotive-grade products in automotive applications. Customer/distributor shall ensure that the terms and conditions of sale between customer/distributor and any customer of distributor/customer (1) state that Micron products are not designed or intended for use in automotive applications unless specifically designated by Micron as automotive-grade by their respective data sheets and (2) require such customer of distributor/customer to indemnify and hold Micron harmless against all claims, costs, damages, and expenses and reasonable attorneys' fees arising out of, directly or indirectly, any claim of product liability, personal injury, death, or property damage resulting from any use of non-automotive-grade products in automotive applications.

**Critical Applications.** Products are not authorized for use in applications in which failure of the Micron component could result, directly or indirectly in death, personal injury, or severe property or environmental damage ("Critical Applications"). Customer must protect against death, personal injury, and severe property and environmental damage by incorporating safety design measures into customer's applications to ensure that failure of the Micron component will not result in such harms. Should customer or distributor purchase, use, or sell any Micron component for any critical application, customer and distributor shall indemnify and hold harmless Micron and its subsidiaries, subcontractors, and affiliates and the directors, officers, and employees of each against all claims, costs, damages, and expenses and reasonable attorneys' fees arising out of, directly or indirectly, any claim of product liability, personal injury, or death arising in any way out of such critical application, whether or not Micron or its subsidiaries, subcontractors, or affiliates were negligent in the design, manufacture, or warning of the Micron product.

**Customer Responsibility.** Customers are responsible for the design, manufacture, and operation of their systems, applications, and products using Micron products. ALL SEMICONDUCTOR PRODUCTS HAVE INHERENT FAILURE RATES AND LIMITED USEFUL LIVES. IT IS THE CUSTOMER'S SOLE RESPONSIBILITY TO DETERMINE WHETHER THE MICRON PRODUCT IS SUITABLE AND FIT FOR THE CUSTOMER'S SYSTEM, APPLICATION, OR PRODUCT. Customers must ensure that adequate design, manufacturing, and operating safeguards are included in customer's applications and products to eliminate the risk that personal injury, death, or severe property or environmental damages will result from failure of any semiconductor component.

**Limited Warranty.** In no event shall Micron be liable for any indirect, incidental, punitive, special or consequential damages (including without limitation lost profits, lost savings, business interruption, costs related to the removal or replacement of any products or rework charges) whether or not such damages are based on tort, warranty, breach of contract or other legal theory, unless explicitly stated in a written agreement executed by Micron's duly authorized representative.



## General Description

Micron e.MMC is a communication and mass data storage device that includes a Multi-MediaCard (MMC) interface, a NAND Flash component, and a controller on an advanced 12-signal bus, which is compliant with the MMC system specification. Its cost per bit, small package sizes, and high reliability make it an ideal choice for automotive applications, including information and entertainment, navigation tools, advanced driving assistance systems, and a variety of other industrial and portable products.

The nonvolatile e.MMC draws no power to maintain stored data, delivers high performance across a wide range of operating temperatures, and resists shock and vibration disruption.



## Signal Descriptions

**Table 8: Signal Descriptions**

Symbol	Type	Description
CLK	Input	Clock: Each cycle of the clock directs a transfer on the command line and on the data line(s). The frequency can vary between the minimum and the maximum clock frequency.
RST_n	Input	Reset: The RST_n signal is used by the host for resetting the device, moving the device to the pre-idle state. By default, the RST_n signal is temporarily disabled in the device. The host must set ECSD register byte 162, bits[1:0] to 0x1 to enable this functionality before the host can use it.
CMD	I/O	Command: This signal is a bidirectional command channel used for command and response transfers. The CMD signal has two bus modes: open-drain mode and push-pull mode. Commands are sent from the MMC host to the device, and responses are sent from the device to the host.
DAT[7:0]	I/O	Data I/O: These are bidirectional data signals. The DAT signals operate in push-pull mode. By default, after power-on or assertion of the RST_n signal, only DAT0 is used for data transfer. The MMC controller can configure a wider data bus for data transfer either using DAT[3:0] (4-bit mode) or DAT[7:0] (8-bit mode). e.MMC includes internal pull-up resistors for data lines DAT[7:1]. Immediately after entering the 4-bit mode, the device disconnects the internal pull-up resistors on the DAT[3:1] lines. Upon entering the 8-bit mode, the device disconnects the internal pull-ups on the DAT[7:1] lines.
DS	Output	Data strobe: Generated by the device and used for data output and CRC status response output in HS400 mode. The frequency of this signal follows the frequency of CLK. For data output, each cycle of this signal directs two bits transfer (2x) on the data, one bit for the positive edge and the other bit for the negative edge. For CRC status response output, the CRC status is latched on the positive edge only, and is "Don't Care" on the negative edge.
V <sub>CC</sub>	Supply	V <sub>CC</sub> : NAND interface (I/F) I/O and NAND Flash power supply.
V <sub>CCQ</sub>	Supply	V <sub>CCQ</sub> : e.MMC controller core and e.MMC I/F I/O power supply.
V <sub>SS</sub> <sup>1</sup>	Supply	V <sub>SS</sub> : NAND I/F I/O and NAND Flash ground connection.
V <sub>SSQ</sub> <sup>1</sup>	Supply	V <sub>SSQ</sub> : e.MMC controller core and e.MMC I/F ground connection.
V <sub>DDIM</sub>	–	Internal voltage node.
NC	–	No connect: No internal connection is present.
RFU	–	Reserved for future use: No internal connection is present. Leave it floating externally.

Note: 1. V<sub>SS</sub> and V<sub>SSQ</sub> are connected internally.



## 153-Ball Signal Assignments

Figure 2: 153 Ball (Top View, Ball Down)

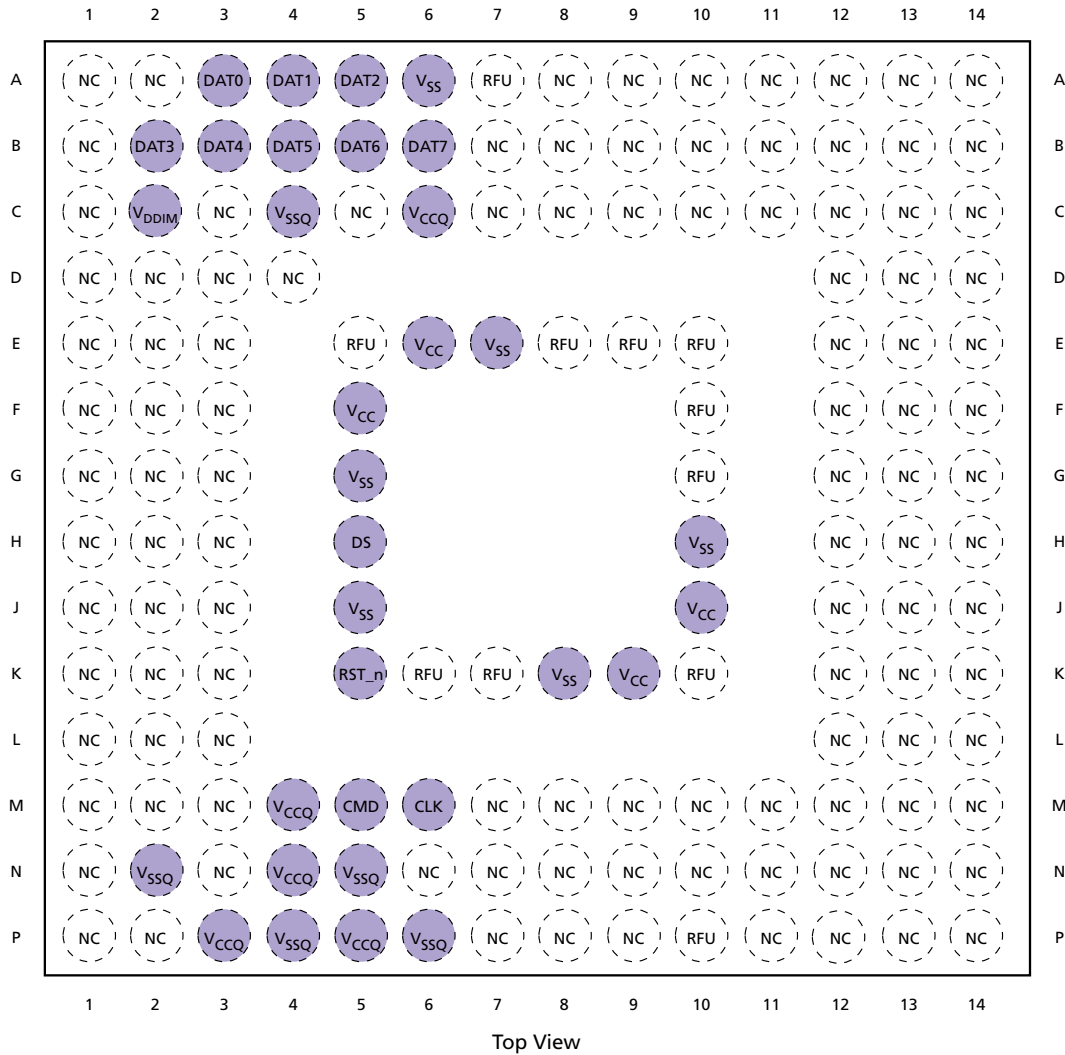

- Notes:
1. Some previous versions of the JEDEC product or mechanical specification had defined reserved for future use (RFU) balls as no connect (NC) balls. NC balls assigned in the previous specifications could have been connected to ground on the system board. To enable new feature introduction, some of these balls are assigned as RFU in the v4.4 mechanical specification. Any new PCB footprint implementations should use the new ball assignments and leave the RFU balls floating on the system board.
  2. VCC, VCCQ, VSS, and VSSQ balls must all be connected on the system board.



## 169-Ball Signal Assignments

Figure 3: 169 Ball (Top View, Ball Down)

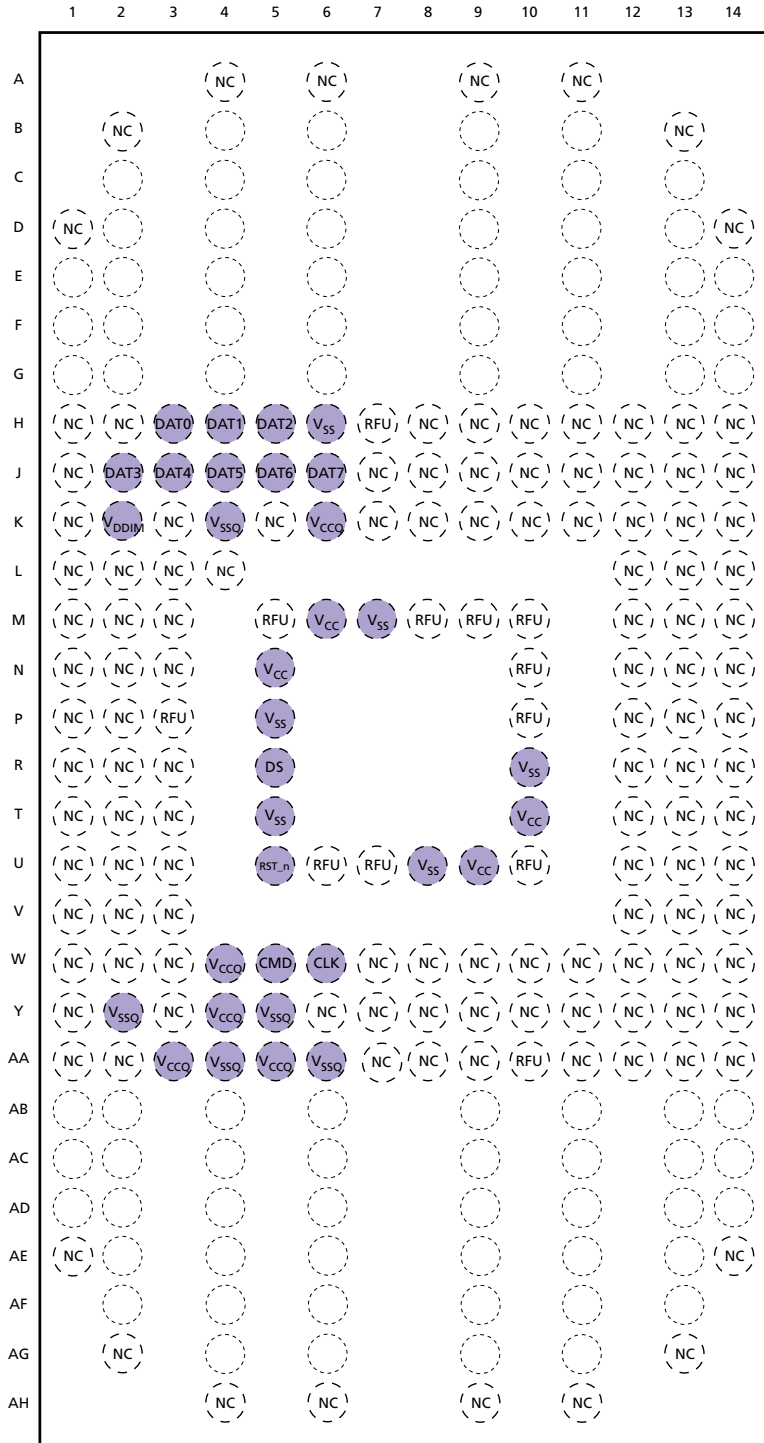

Notes: 1. Empty balls do not denote actual solder balls; they are position indicators only.



## 8GB, 16GB, 32GB, 64GB, 128GB: e.MMC 169-Ball Signal Assignments

---

2. Some previous versions of the JEDEC product or mechanical specification had defined reserved for future use (RFU) balls as no connect (NC) balls. NC balls assigned in the previous specifications could have been connected to ground on the system board. To enable new feature introduction, some of these balls are assigned as RFU in the JEDEC specification. Any new PCB footprint implementations should use the new ball assignments and leave the RFU balls floating on the system board.
3.  $V_{CC}$ ,  $V_{CCQ}$ ,  $V_{SS}$ , and  $V_{SSQ}$  balls must all be connected on the system board.



## Package Dimensions

Figure 4: 153-Ball TFBGA – 11.5mm × 13.0mm × 1.2mm (Package Code: NS)

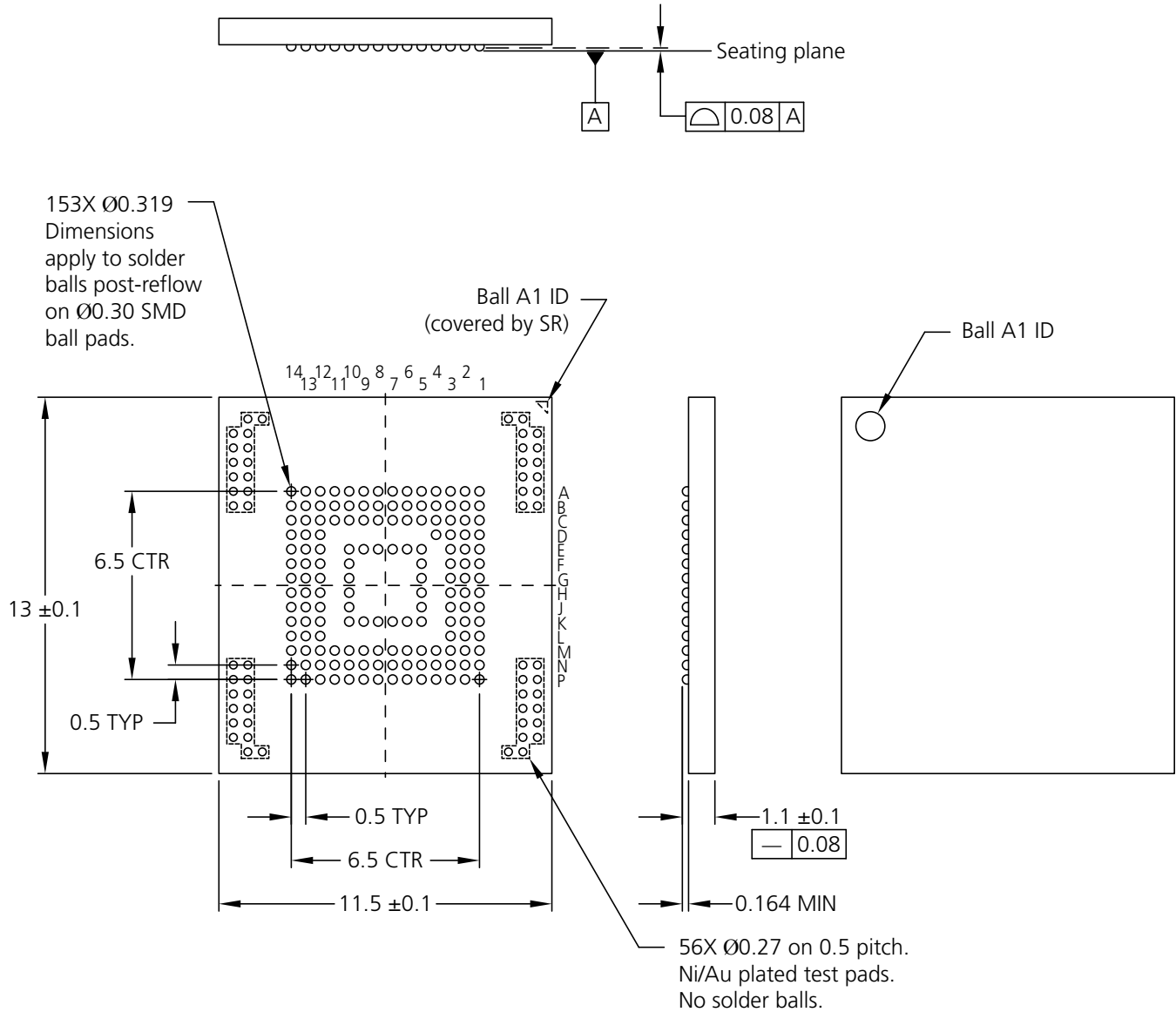

Note: 1. Dimensions are in millimeters.



Figure 5: 153-Ball VFBGA – 11.5mm × 13.0mm × 1.0mm (Package Code: CN, JP)

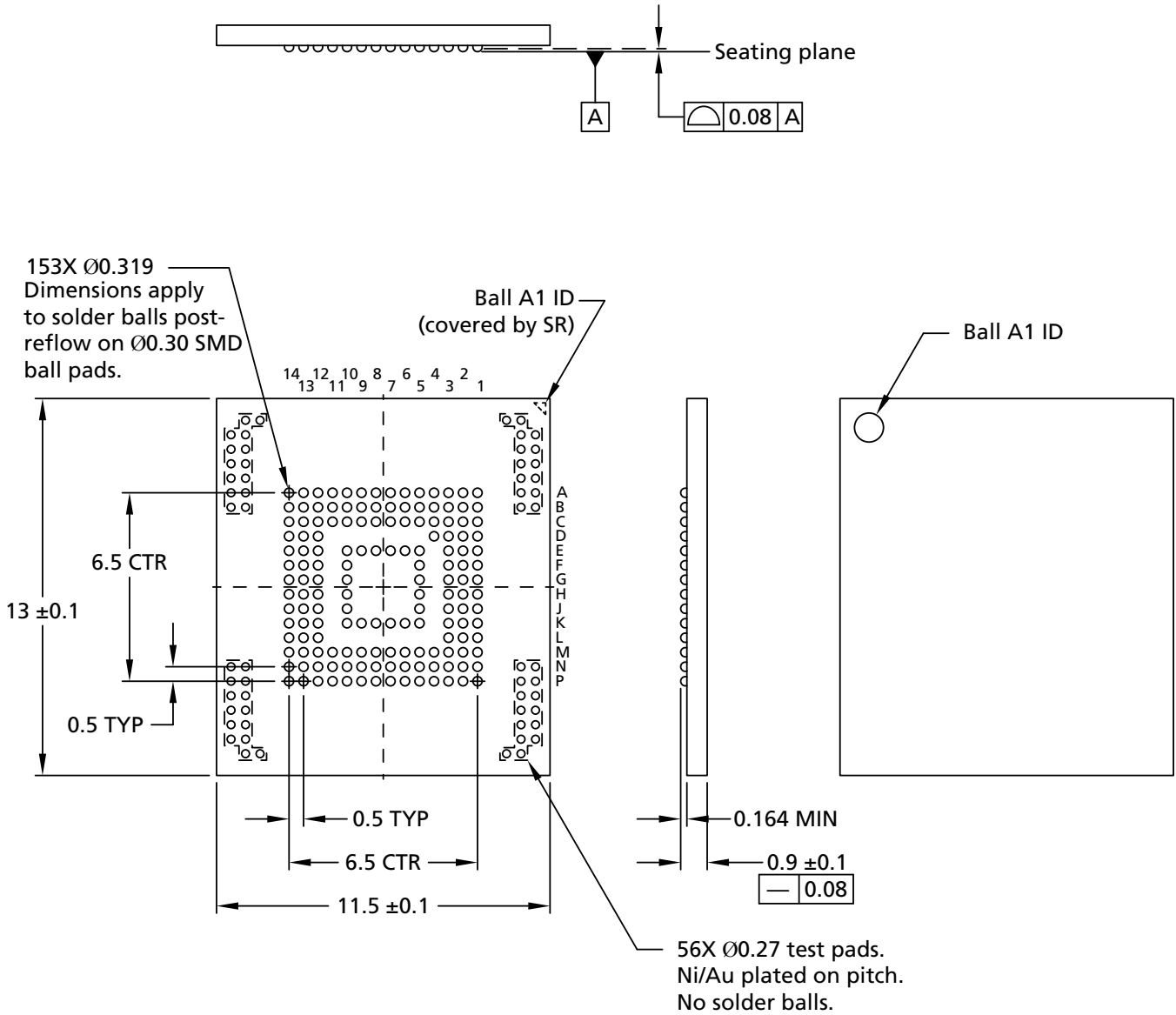

Note: 1. Dimensions are in millimeters.



Figure 6: 169-Ball LFBGA – 14mm x 18mm x 1.4mm (Package Code: CE, DN)

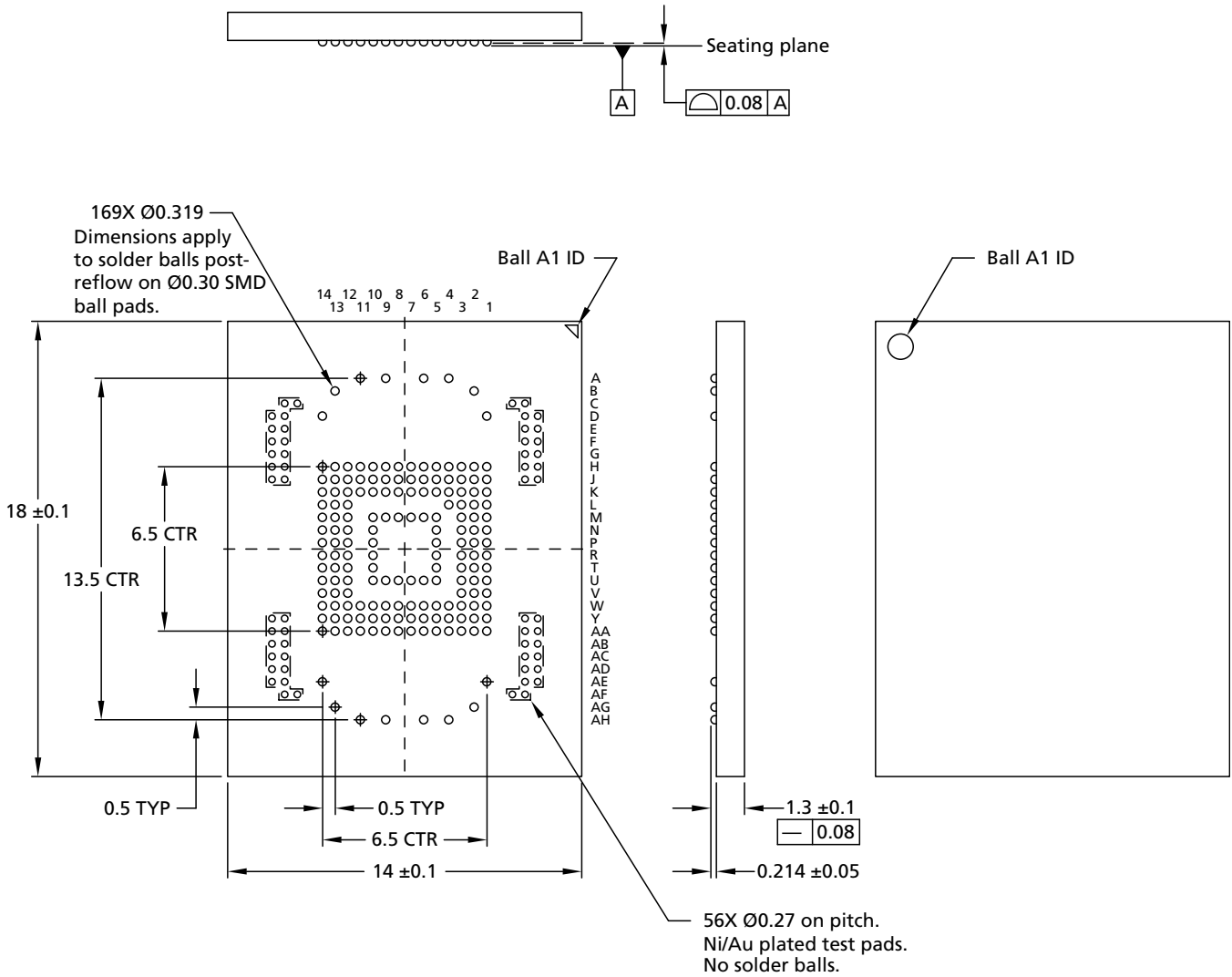

Note: 1. Dimensions are in millimeters.



## Architecture

**Figure 7: e.MMC Functional Block Diagram**

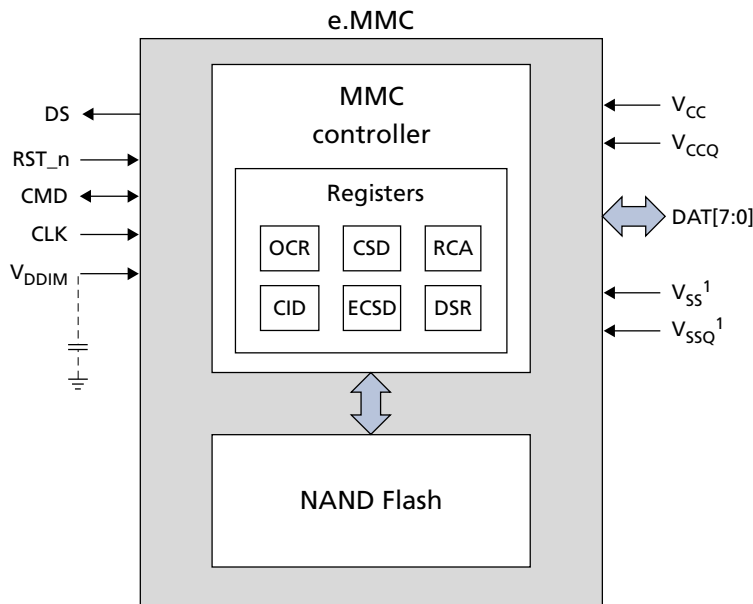

Note: 1. V<sub>SS</sub> and V<sub>SSQ</sub> are internally connected.

### MMC Protocol Independent of NAND Flash Technology

The MMC specification defines the communication protocol between a host and a device. The protocol is independent of the NAND Flash features included in the device. The device has an intelligent on-board controller that manages the MMC communication protocol.

The controller also handles block management functions such as logical block allocation and wear leveling. These management functions require complex algorithms and depend entirely on NAND Flash technology (generation or memory cell type).

The device handles these management functions internally, making them invisible to the host processor.

### Defect and Error Management

Micron e.MMC incorporates advanced technology for defect and error management. If a defective block is identified, the device completely replaces the defective block with one of the spare blocks. This process is invisible to the host and does not affect data space allocated for the user.

The device also includes a built-in error correction code (ECC) algorithm to ensure that data integrity is maintained.

To make the best use of these advanced technologies and ensure proper data loading and storage over the life of the device, the host must exercise the following precautions:

- Check the status after WRITE, READ, and ERASE operations.
- Avoid power-down during WRITE and ERASE operations.



## OCR Register

The 32-bit operation conditions register (OCR) stores the voltage profile of the card and the access mode indication. In addition, this register includes a status information bit.

**Table 9: OCR Parameters**

OCR Bits	OCR Value	Description
[31]	1b (ready)/0b (busy) <sup>1</sup>	Device power-on status bit
[30:29]	10b	Sector mode
[28:24]	0 0000b	Reserved
[23:15]	1 1111 1111b	2.7–3.6V voltage range
[14:8]	000 0000b	2.0–2.7V voltage range
[7]	1b	1.70–1.95V voltage range
[6:0]	000 0000b	Reserved

Note: 1. OCR = C0FF8080h after the device has completed power-up.



## CID Register

The card identification (CID) register is 128 bits wide. It contains the device identification information used during the card identification phase as required by *e.MMC* protocol. Each device is created with a unique identification number.

**Table 10: CID Register Field Parameters**

Name	Field	Width	CID Bits	CID Value
Manufacturer ID	MID	8	[127:120]	13h
Reserved	–	6	[119:114]	–
Card/BGA	CBX	2	[113:112]	01h
OEM/application ID	OID	8	[111:104]	–
Product name	PNM	48	[103:56]	8GB: 0x52314A353541 (R1J55A)
				16GB: 0x52314A35364C (R1J56L)
				32GB: 0x52314A35374C (R1J57L)
				64GB: 0x52314A353845 (R1J58E)
				128GB: 0x52314A353945 (R1J59E)
Product revision	PRV	8	[55:48]	–
Product serial number	PSN	32	[47:16]	–
Manufacturing date	MDT	8	[15:8]	–
CRC7 checksum	CRC	7	[7:1]	–
Not used; always 1	–	1	0	–



## CSD Register

The card-specific data (CSD) register provides information about accessing the device contents. The CSD register defines the data format, error correction type, maximum data access time, and data transfer speed, as well as whether the DS register can be used. The programmable part of the register (entries marked with W or E in the following table) can be changed by the PROGRAM\_CSD (CMD27) command.

**Table 11: CSD Register Field Parameters**

Name	Field	Density	Size (Bits)	Cell Type <sup>1</sup>	CSD Bits	CSD Value
CSD structure	CSD_STRUCTURE	–	2	R	[127:126]	3h
System specification version	SPEC_VERS	–	4	R	[125:122]	4h
Reserved <sup>2</sup>	–	–	2	–	[121:120]	–
Data read access time 1 <sup>3</sup>	TAAC	–	8	R	[119:112]	7Fh
Data read access time 2 in CLK cycles (NSAC × 100)	NSAC	–	8	R	[111:104]	01h
Maximum bus clock frequency	TRAN_SPEED	–	8	R	[103:96]	32h
Card command classes	CCC	–	12	R	[95:84]	0F5h
Maximum read data block length	READ_BLK_LEN	–	4	R	[83:80]	09h
Partial blocks for reads supported	READ_BLK_PARTIAL	–	1	R	[79]	0h
Write block misalignment	WRITE_BLK_MISALIGN	–	1	R	[78]	0h
Read block misalignment	READ_BLK_MISALIGN	–	1	R	[77]	0h
DSR implemented	DSR_IMP	–	1	R	[76]	0h
Reserved	–	–	2	–	[75:74]	–
Device size	C_SIZE	–	12	R	[73:62]	FFFh
Maximum read current at V <sub>DD,min</sub>	VDD_R_CURR_MIN	–	3	R	[61:59]	07h
Maximum read current at V <sub>DD,max</sub>	VDD_R_CURR_MAX	–	3	R	[58:56]	07h
Maximum write current at V <sub>DD,min</sub>	VDD_W_CURR_MIN	–	3	R	[55:53]	07h
Maximum write current at V <sub>DD,max</sub>	VDD_W_CURR_MAX	–	3	R	[52:50]	07h
Device size multiplier	C_SIZE_MULT	–	3	R	[49:47]	07h
Erase group size	ERASE_GRP_SIZE	–	5	R	[46:42]	1Fh
Erase group size multiplier	ERASE_GRP_MULT	–	5	R	[41:37]	1Fh
Write protect group size	WP_GRP_SIZE	–	5	R	[36:32]	0Fh
Write protect group enable	WP_GRP_ENABLE	–	1	R	[31]	01h
Manufacturer default ECC	DEFAULT_ECC	–	2	R	[30:29]	0h
Write-speed factor <sup>3</sup>	R2W_FACTOR	–	3	R	[28:26]	01h

**Table 11: CSD Register Field Parameters (Continued)**

Name	Field	Density	Size (Bits)	Cell Type <sup>1</sup>	CSD Bits	CSD Value
Maximum write data block length	WRITE_BL_LEN	–	4	R	[25:22]	09h
Partial blocks for writes supported	WRITE_BL_PARTIAL	–	1	R	[21]	0h
Reserved	–	–	4	–	[20:17]	–
Content protection application	CONTENT_PROT_APP	–	1	R	[16]	0h
File-format group	FILE_FORMAT_GRP	–	1	R/W	[15]	0h
Copy flag (OTP)	COPY	–	1	R/W	[14]	0h
Permanent write protection	PERM_WRITE_PROTECT	–	1	R/W	[13]	0h
Temporary write protection	TMP_WRITE_PROTECT	–	1	R/W/E	[12]	0h
File format	FILE_FORMAT	–	2	R/W	[11:10]	0h
ECC	ECC	–	2	R/W/E	[9:8]	0h
CRC	CRC	–	7	R/W/E	[7:1]	–
Reserved	–	–	1	–	[0]	–

- Notes:
1. R = Read-only;  
R/W = One-time programmable and readable;  
R/W/E = Multiple writable with value kept after a power cycle, assertion of the RST\_n signal, and any CMD0 reset, and readable
  2. Reserved bits should be read as 0.
  3. The reported values of TAAC and R2W\_FACTOR include reliability routines and automotive refresh features. Typical values are much lower. Refer to local Micron support for information.



## ECSD Register

The 512-byte extended card-specific data (ECSD) register defines device properties and selected modes. The most significant 320 bytes are the properties segment. This segment defines device capabilities and cannot be modified by the host. The lower 192 bytes are the modes segment. The modes segment defines the configuration in which the device is working. The host can change the properties of modes segments using the SWITCH command.

**Table 12: ECSD Register Field Parameters**

Name	Field	Density	Size (Bytes)	Cell Type <sup>1</sup>	ECSD Bytes	ECSD Value
<b>Properties Segment</b>						
Reserved <sup>2</sup>	–	–	6	TBD	[511:506]	–
Extended security error support	EXT_SECURITY_ERR	–	1	R	[505]	00h
Supported command sets	S_CMD_SET	–	1	R	[504]	01h
HPI features	HPI_FEATURES	–	1	R	[503]	01h
Background operations support	BKOPS_SUPPORT	–	1	R	[502]	01h
Max-packed read commands	MAX_PACKED_READS	–	1	R	[501]	3Fh
Max-packed write commands	MAX_PACKED_WRITES	–	1	R	[500]	3Fh
Data tag support	DATA_TAG_SUPPORT	–	1	R	[499]	01h
Tag unit size	TAG_UNIT_SIZE	–	1	R	[498]	03h
Tag resources size	TAG_RES_SIZE	–	1	R	[497]	00h
Context management capabilities	CONTEXT_CAPABILITIES	–	1	R	[496]	05h
Large unit size	LARGE_UNIT_SIZE_M1	–	1	R	[495]	03h
Extended partitions attribute support	EXT_SUPPORT	–	1	R	[494]	03h
Supported modes	SUPPORTED_MODES	–	1	R	[493]	01h
Field firmware update features	FFU_FEATURES	–	1	R	[492]	00h
Operation code timeout	OPERATION_CODE_TIMEOUT	–	1	R	[491]	00h
Field firmware update arguments	FFU_ARG	–	4	R	[490:487]	0000FFFFh
Reserved	–	–	181	TBD	[486:306]	–
Number of firmware sectors correctly programmed	NUMBER_OF_FW_SECTORS_CORRECTLY_PROGRAMMED	–	4	R	[305:302]	00h
Vendor proprietary health report	VENDOR_PROPRIETARY_HEALTH_REPORT	–	32	R	[301:270]	00h
Device life time estimate type B	DEVICE_LIFE_TIME_EST_TYP_B	–	1	R	[269]	01h

**Table 12: ECSD Register Field Parameters (Continued)**

Name	Field	Density	Size (Bytes)	Cell Type <sup>1</sup>	ECSD Bytes	ECSD Value
Device life time estimate type A	DEVICE_LIFE_TIME_EST_TYP_A	–	1	R	[268]	01h
Pre-end of life information	PRE_EOL_INFO	–	1	R	[267]	01h
Optimal read size	OPTIMAL_READ_SIZE	–	1	R	[266]	0h
Optimal write size	OPTIMAL_WRITE_SIZE	–	1	R	[265]	40h
Optimal trim unit size	OPTIMAL_TRIM_UNIT_SIZE	–	1	R	[264]	07h
Device version	DEVICE_VERSION	–	2	R	[263:262]	0000h
Firmware version	FIRMWARE_VERSION	–	8	R	[261:254]	–
Power class for 200 MHz DDR at V <sub>CC</sub> = 3.6V	PWR_CL_DDR_200_360	–	1	R	[253]	–
Cache size	CACHE_SIZE	8GB	4	R	[252:249]	00000800h
		16GB				00001000h
		32GB				00002000h
		64GB				
		128GB				
Generic CMD6 timeout	GENERIC_CMD6_TIME	–	1	R	[248]	0Ah
Power-off notification (long) timeout	POWER_OFF_LONG_TIME	–	1	R	[247]	32h
Background operations status	BKOPS_STATUS	–	1	R	[246]	00h
Number of correctly programmed sectors	CORRECTLY_PROG_SECTORS_NUM	–	4	R	[245:242]	00000000h
First initialization time after partitioning (first CMD1 to device ready)	INI_TIMEOUT_AP	–	1	R	[241]	1Eh
Reserved	–	–	1	TBD	[240]	–
Power class for 52 MHz, DDR at 3.6V	PWR_CL_DDR_52_360	–	1	R	[239]	–
Power class for 52 MHz, DDR at 1.95V	PWR_CL_DDR_52_195	–	1	R	[238]	–
Power class for 200 MHz at 1.95V	PWR_CL_200_195	–	1	R	[237]	–
Power class for 200 MHz, at 1.3V	PWR_CL_200_130	–	1	R	[236]	–
Minimum write performance for 8-bit at 52 MHz in DDR mode	MIN_PERF_DDR_W_8_52	–	1	R	[235]	–
Minimum read performance for 8-bit at 52 MHz in DDR mode	MIN_PERF_DDR_R_8_52	–	1	R	[234]	–

**Table 12: ECSD Register Field Parameters (Continued)**

Name	Field	Density	Size (Bytes)	Cell Type <sup>1</sup>	ECSD Bytes	ECSD Value
Reserved	–	–	1	TBD	[233]	–
TRIM multiplier	TRIM_MULT	–	1	R	[232]	02h
Secure feature support	SEC_FEATURE_SUPPORT	–	1	R	[231]	55h
Secure erase multiplier	SEC_ERASE_MULT	–	1	R	[230]	1Bh
Secure trim multiplier	SEC_TRIM_MULT	–	1	R	[229]	11h
Boot information	BOOT_INFO	–	1	R	[228]	07h
Reserved	–	–	1	TBD	[227]	–
Boot partition size <sup>3</sup>	BOOT_SIZE_MULT	–	1	R	[226]	FCh
Access size	ACC_SIZE	8GB	1	R	[225]	07h
		16GB				
		32GB				
		64GB				
		128GB				
High-capacity erase unit size	HC_ERASE_GRP_SIZE	–	1	R	[224]	01h
High-capacity erase time-out	ERASE_TIMEOUT_MULT	–	1	R	[223]	01h
Reliable write-sector count	REL_WR_SEC_C	–	1	R	[222]	01h
High-capacity write protect group size	HC_WP_GRP_SIZE	8GB	1	R	[221]	10h
		16GB				
		32GB				
		64GB				
		128GB				
						20h
						40h
Sleep current (V <sub>CC</sub> )	S_C_VCC	–	1	R	[220]	08h
Sleep current (V <sub>CCQ</sub> )	S_C_VCCQ	–	1	R	[219]	09h
Production state awareness timeout	PRODUCTION_STATE_AWARENESS_TIMEOUT	–	1	TBD	[218]	00h
Sleep/awake timeout	S_A_TIMEOUT	–	1	R	[217]	14h
Sleep notification timeout	SLEEP_NOTIFICATION_TIME	–	1	TBD	[216]	0Dh
Sector count <sup>4</sup>	SEC_COUNT	8GB	4	R	[215:212]	00E90000h
		16GB				01D5C000h
		32GB				03A40000h
		64GB				07690000h
		128GB				0E8F8000h
Reserved	–	–	1	TBD	[211]	–
Minimum write performance for 8-bit at 52 MHz	MIN_PERF_W_8_52	–	1	R	[210]	–

**Table 12: ECSD Register Field Parameters (Continued)**

Name	Field	Density	Size (Bytes)	Cell Type <sup>1</sup>	ECSD Bytes	ECSD Value
Minimum read performance for 8-bit at 52 MHz	MIN_PERF_R_8_52	–	1	R	[209]	–
Minimum write performance for 8-bit at 26 MHz and 4-bit at 52 MHz	MIN_PERF_W_8_26_4_52	–	1	R	[208]	–
Minimum read performance for 8-bit at 26 MHz and 4-bit at 52 MHz	MIN_PERF_R_8_26_4_52	–	1	R	[207]	–
Minimum write performance for 4-bit at 26 MHz	MIN_PERF_W_4_26	–	1	R	[206]	–
Minimum read performance for 4-bit at 26 MHz	MIN_PERF_R_4_26	–	1	R	[205]	–
Reserved	–	–	1	TBD	[204]	–
Power class for 26 MHz at 3.6V	PWR_CL_26_360	–	1	R	[203]	–
Power class for 52 MHz at 3.6V	PWR_CL_52_360	–	1	R	[202]	–
Power class for 26 MHz at 1.95V	PWR_CL_26_195	–	1	R	[201]	–
Power class for 52 MHz at 1.95V	PWR_CL_52_195	–	1	R	[200]	–
Partition switching timing	PARTITION_SWITCH_TIME	–	1	R	[199]	01h
Out-of-interrupt busy timing	OUT_OF_INTERRUPT_TIME	–	1	R	[198]	0Fh
I/O driver strength	DRIVER_STRENGTH	–	1	R	[197]	1Fh
Device type	DEVICE_TYPE	–	1	R	[196]	57h
Reserved	–	–	1	TBD	[195]	–
CSD structure version	CSD_STRUCTURE	–	1	R	[194]	02h
Reserved	–	–	1	TBD	[193]	–
Extended CSD revision	EXT_CSD_REV	–	1	R	[192]	07h
<b>Modes Segment</b>						
Command set	CMD_SET	–	1	R/W/E_P	[191]	00h
Reserved	–	–	1	TBD	[190]	–
Command set revision	CMD_SET_REV	–	1	R	[189]	00h
Reserved	–	–	1	TBD	[188]	–
Power class	POWER_CLASS	–	1	R/W/E_P	[187]	00h
Reserved	–	–	1	TBD	[186]	–
High-speed interface timing	HS_TIMING	–	1	R/W/E_P	[185]	00h
Reserved	–	–	1	TBD	[184]	–

**Table 12: ECSD Register Field Parameters (Continued)**

Name	Field	Density	Size (Bytes)	Cell Type <sup>1</sup>	ECSD Bytes	ECSD Value
Bus width mode	BUS_WIDTH	–	1	W/E_P	[183]	00h
Reserved	–	–	1	TBD	[182]	–
Erased memory content	ERASED_MEM_CONT	–	1	R	[181]	00h
Reserved	–	–	1	TBD	[180]	–
Partition configuration	PARTITION_CONFIG	–	1	R/W/E, R/W/E_P	[179]	00h
Boot configuration protection	BOOT_CONFIG_PROT	–	1	R/W, R/W/C_P	[178]	00h
Boot bus conditions	BOOT_BUS_CONDITIONS	–	1	R/W/E	[177]	00h
Reserved	–	–	1	TBD	[176]	–
High-density erase group definition	ERASE_GROUP_DEF	–	1	R/W/E_P	[175]	00h
Boot write protection status registers	BOOT_WP_STATUS	–	1	R	[174]	00h
Boot area write protection register	BOOT_WP	–	1	R/W, R/W/C_P	[173]	00h
Reserved	–	–	1	TBD	[172]	–
User write protection register	USER_WP	–	1	R/W, R/W/C_P, R/W/E_P	[171]	00h
Reserved	–	–	1	TBD	[170]	–
Firmware configuration	FW_CONFIG	–	1	R/W	[169]	00h
RPMB size	RPMB_SIZE_MULT	–	1	R	[168]	20h
Write reliability setting register <sup>5</sup>	WR_REL_SET	–	1	R/W	[167]	1Fh
Write reliability parameter register	WR_REL_PARAM	–	1	R	[166]	15h
SANITIZE START operation	SANITIZE_START	–	1	W/E_P	[165]	00h
Manually start background operations	BKOPS_START	–	1	W/E_P	[164]	00h
Enable background operations handshake	BKOPS_EN	–	1	R/W	[163]	00h
Hardware reset function	RST_n_FUNCTION	–	1	R/W	[162]	00h
HPI management	HPI_MGMT	–	1	R/W/E_P	[161]	00h
Partitioning support	PARTITIONING_SUPPORT	–	1	R	[160]	07h
Maximum enhanced area size	MAX_ENH_SIZE_MULT	8GB	3	R	[159:157]	0001C9h
		16GB				0003A2h
		32GB				00073Eh
		64GB				000764h
		128GB				000745h

**Table 12: ECSD Register Field Parameters (Continued)**

Name	Field	Density	Size (Bytes)	Cell Type <sup>1</sup>	ECSD Bytes	ECSD Value
Partitions attribute	PARTITIONS_ATTRIBUTE	–	1	R/W	[156]	00h
Partitioning setting	PARTITION_SETTING_COMPLETED	–	1	R/W	[155]	00h
General-purpose partition size	GP_SIZE_MULT	–	12	R/W	[154:143]	00h
Enhanced user data area size	ENH_SIZE_MULT	–	3	R/W	[142:140]	000000h
Enhanced user data start address	ENH_START_ADDR	–	4	R/W	[139:136]	00000000h
Reserved	–	–	1	TBD	[135]	–
Bad block management mode	SEC_BAD_BLK_MGMNT	–	1	R/W	[134]	00h
Production state awareness	PRODUCTION_STATE_AWARENESS	–	1	TBD	[133]	00h
Package case temperature is controlled	TCASE_SUPPORT	–	1	W/E_P	[132]	00h
Periodic wake-up	PERIODIC_WAKEUP	–	1	R/W/E	[131]	00h
Program CID/CSD in DDR mode support	PROGRAM_CID_CSD_DDR_SUPPORT	–	1	R	[130]	01h
Reserved	–	–	2	TBD	[129:128]	–
Vendor specific fields	VENDOR_SPECIFIC_FIELD	–	64	<vendor specific>	[127:64]	–
Native sector size	NATIVE_SECTOR_SIZE	–	1	R	[63]	00h
Sector size emulation	USE_NATIVE_SECTOR	–	1	R/W	[62]	00h
Sector size	DATA_SECTOR_SIZE	–	1	R	[61]	00h
1st initialization after disabling sector size emulation	INI_TIMEOUT_EMU	–	1	R	[60]	00h
Class 6 commands control	CLASS_6_CTRL	–	1	R/W/E_P	[59]	00h
Number of addressed group to be released	DYNCAP_NEEDED	–	1	R	[58]	00h
Exception events control	EXCEPTION_EVENTS_CTRL	–	2	R/W/E_P	[57:56]	0000h
Exception events status	EXCEPTION_EVENTS_STATUS	–	2	R	[55:54]	0000h
Extended partitions attribute	EXT_PARTITIONS_ATTRIBUTE	–	2	R/W	[53:52]	0000h
Context configuration	CONTEXT_CONF	–	15	R/W/E_P	[51:37]	00h
Packed command status	PACKED_COMMAND_STATUS	–	1	R	[36]	00h
Packed command failure index	PACKED_FAILURE_INDEX	–	1	R	[35]	00h
Power-off notification	POWER_OFF_NOTIFICATION	–	1	R/W/E_P	[34]	00h
Control to turn the cache on/off	CACHE_CTRL	–	1	R/W/E_P	[33]	00h

**Table 12: ECSD Register Field Parameters (Continued)**

Name	Field	Density	Size (Bytes)	Cell Type <sup>1</sup>	ECSD Bytes	ECSD Value
Flushing of the cache	FLUSH_CACHE	–	1	W/E_P	[32]	00h
Reserved	–	–	1	TBD	[31]	–
Mode configuration	MODE_CONFIG	–	1	R/W/E_P	[30]	00h
Mode operation codes	MODE_OPERATION_CODES	–	1	W/E_P	[29]	00h
Reserved	–	–	2	TBD	[28:27]	–
Field firmware update status	FFU_STATUS	–	1	R	[26]	00h
Pre-loading data size	PRE_LOADING_DATA_SIZE	–	4	R/W/E_P	[25:22]	00h
Maximum pre-loading data size	MAX_PRE_LOADING_DATA_SIZE	–	4	R	[21:18]	TBD
Product state awareness enablement	PRODUCT_STATE_AWARENESS_ENABLEMENT	–	1	R/W/E&R	[17]	00h
Secure removal type	SECURE_REMOVAL_TYPE	–	1	R/W/E&R	[16]	01h
Reserved	–	–	16	TBD	[15:0]	–

- Notes:
1. R = Read-only;  
R/W = One-time programmable and readable;  
R/W/E = Multiple writable with the value kept after a power cycle, assertion of the RST<sub>n</sub> signal, and any CMD0 reset, and readable;  
R/W/C\_P = Writable after the value is cleared by a power cycle and assertion of the RST<sub>n</sub> signal (the value not cleared by CMD0 reset) and readable;  
R/W/E\_P = Multiple writable with the value reset after a power cycle, assertion of the RST<sub>n</sub> signal, and any CMD0 reset, and readable;  
W/E\_P = Multiple writable with the value reset after power cycle, assertion of the RST<sub>n</sub> signal, and any CMD0 reset, and not readable
  2. Reserved bits should be read as 0.
  3. Boot partition size is configurable by host. Refer to local Micron support for information.
  4. When the partition configuration is applied to the device, the SEC\_COUNT value is recalculated to indicate the size of user data area after the partition. In case of the enhanced full partition set for 8GB, SEC COUNT is 724000h.
  5. Micron has tested power failure under best-application knowledge conditions with positive results. Customers may request a dedicated test for their specific application condition. Micron set this register during factory test and used the one-time programming option.



## DC Electrical Specifications – Device Power

The device current consumption for various device configurations is defined in the power class fields of the ECSD register.

$V_{CC}$  is used for the NAND Flash device and its interface voltage;  $V_{CCQ}$  is used for the controller and the e-MMC interface voltage.

**Figure 8: Device Power Diagram**

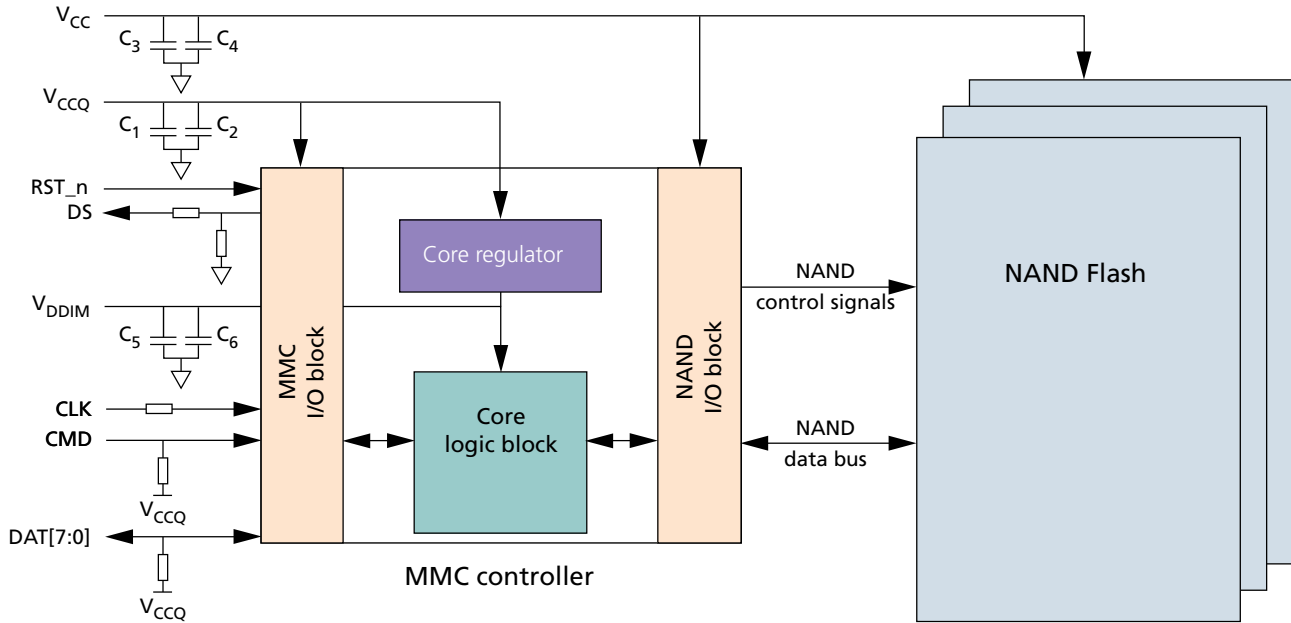

**Table 13: Absolute Maximum Ratings**

Parameters	Symbol	Min	Max	Unit
Voltage input	$V_{IN}$	-0.6	4.6	V
$V_{CC}$ supply	$V_{CC}$	-0.6	4.6	V
$V_{CCQ}$ supply	$V_{CCQ}$	-0.6	4.6	V

Note: 1. Voltage on any pin relative to  $V_{SS}$ .

**Table 14: Temperature Grade**

Temperature Grade	Condition	Ambient Temperature - $T_a$	Unit
AIT	Operating	-40 to 85	°C
	Storage		
AAT <sup>1</sup>	Operating	-40 to 105	°C
	Storage		

Note: 1.  $T_{case}$  for 16GB and 32GB can go up to 115°C.

**Table 15: Capacitor and Resistance Specifications**

Parameter	Symbol	Min	Max	Typ	Units	Notes
Pull-up resistance: CMD	R_CMD	4.7	50	10	kΩ	1
Pull-up resistance: DAT[7:0]	R_DAT	10	50	50	kΩ	1
Pull-up resistance: RST_n	R_RST_n	4.7	50	50	kΩ	2
CLK/CMD/DS/DAT[7:0] impedance		45	55	50	Ω	3
Serial resistance on CLK	SR_CLK	0	47	22	Ω	
Serial resistance on DS	SR_DS	0	47	22	Ω	4
Pull-down resistance: DS	R_DS	10	100	–	kΩ	
V <sub>CCQ</sub> capacitor	C1	2.2	4.7	2.2	μF	5
	C2	0.1	0.22	0.1		
V <sub>CC</sub> capacitor	C3	2.2	4.7	2.2	μF	6
	C4	0.1	0.22	0.1		
V <sub>DDIM</sub> capacitor (C <sub>reg</sub> )	C5	1	4.7	1	μF	7
	C6	0.1	0.1	0.1		

- Notes:
- Used to prevent bus floating.
  - If host does not use H/W RESET (RST\_n), pull-up resistance is not needed on RST\_n line (Extended\_CSD[162] = 00h).
  - Impedance match.
  - Recommended in order to compensate eventual impedance mismatch on the PCB.
  - The coupling capacitor should be connected with V<sub>CCQ</sub> and V<sub>SSQ</sub> as closely as possible.
  - The coupling capacitor should be connected with V<sub>CC</sub> and V<sub>SS</sub> as closely as possible.
  - The coupling capacitor should be connected with V<sub>DDIM</sub> and V<sub>SS</sub> as closely as possible.



## Revision History

### Rev. G – 08/18

- Added Important Notes and Warnings section for further clarification aligning to industry standards

### Rev. F – 06/18

- Added  $T_{\text{case}}$  information for 16GB and 32GB

### Rev. E – 12/17

- Added Important Notes and Warnings section for further clarification aligning to industry standards
- Updated legal status to Production: 16GB and 32GB in JP package, and 64GB and 128GB in CE package with AIT and AAT temperature range

### Rev. D – 11/17

- Added 64GB and 128GB in AAT temperature range as Preliminary status

### Rev. C – 06/17

- Added 16GB and 32GB with JP package code
- Added 64GB with CE package code
- Added 128GB in Preliminary status
- Updated 169-ball package drawing: offset value to nominal with tolerance

### Rev. B – 04/17

- Updated 8GB and 64GB parts to Production
- Updated front page style
- Modified the style of note for the Performance tables and Current Consumption tables

### Rev. A – 04/16

- Initial release

8000 S. Federal Way, P.O. Box 6, Boise, ID 83707-0006, Tel: 208-368-4000  
[www.micron.com/products/support](http://www.micron.com/products/support) Sales inquiries: 800-932-4992  
 Micron and the Micron logo are trademarks of Micron Technology, Inc.  
 All other trademarks are the property of their respective owners.

This data sheet contains minimum and maximum limits specified over the power supply and temperature range set forth herein. Although considered final, these specifications are subject to change, as further product development and data characterization sometimes occur.