



# Industrial eMMC 5.1 Specification

(XTRA V Series, 3D pSLC, 153ball)

Version 1.6

Address: 28 Genting Lane, #09-03/04/05 Platinum 28, Singapore 349585

Tel : +65-6493 5035

Fax : +65-6493 5037

Website: <http://www.flexxon.com>

Email: [flexxon@flexxon.com](mailto:flexxon@flexxon.com)

ALL RIGHTS ARE STRICTLY RESERVED. ANY PORTION OF THIS PAPER SHALL NOT BE REPRODUCED, COPIED, OR TRANSLATED TO ANY OTHER FORMS WITHOUT PERMISSION FROM FLEXXON.

## TABLE OF CONTENTS

<b>1.</b>	<b>General Description.....</b>	<b>3</b>
1.1.	Introduction .....	3
1.2.	Product Overview .....	3
1.3.	3D pSLC .....	4
<b>2.</b>	<b>Product Specifications .....</b>	<b>5</b>
2.1.	Performance .....	5
2.2.	Power Consumption .....	5
2.3.	Partition Capacity .....	5
<b>3.</b>	<b>Interface Description .....</b>	<b>6</b>
3.1.	FLEXXON eMMC I/F Ball Array.....	6
3.2.	Pins and Signal Description.....	7
<b>4.</b>	<b>eMMC Registers.....</b>	<b>8</b>
4.1.	OCR Register.....	8
4.2.	CID Register .....	8
4.3.	CSD Register .....	9
4.4.	Extended CSD Register.....	10
4.5.	RCA Register.....	10
4.6.	DSR Register .....	10
<b>5.</b>	<b>Electrical characteristics .....</b>	<b>11</b>
5.1.	Power Supply.....	11
5.2.	Bus Signal Levels .....	11
5.3.	Bus Timing .....	12
<b>6.</b>	<b>Package .....</b>	<b>21</b>
<b>7.</b>	<b>ORDERING INFORMATION .....</b>	<b>23</b>

# 1. GENERAL DESCRIPTION



## 1.1. Introduction

FLEXXON's XTRA V eMMC is fully comply with JEDEC eMMC5.1 Standard. It is combine of an embedded flash controller and 3D NAND flash memory in one JEDEC standard package, 153Balls (11.5mm x 13mm). FLEXXON eMMC provides high performance, good reliability and advanced power management. It is suitable for small, low power electronic devices.

## 1.2. Product Overview

FLEXXON XTRA V eMMC 5.1 includes the following features:

- Compliant with eMMC Specification Ver. 4.4, 4.41, 4.5, 5.0, 5.1
- Package of eMMC
  - 11.5 mm x 13 mm x 1.0 mm
- Temperature Range
  - Operation: -25°C ~ 85°C
  - Storage: -40°C ~ 85°C
- Operating Voltage
  - VCC: 3.3V
  - VCCQ: 1.8V/3.3V
- Bus Mode
  - High-speed eMMC protocol
  - Clock frequency: 0 ~ 200MHz
- Supports three data bus widths: 1 bit (default), 4 bits, 8 bits
- Supports High Speed Mode HS400
- Supports Production State Awareness
- Supports Field Firmware Update
- Supports Power Off Notification
- Support Enhanced Data Strobe
- Support Secure Write Protection
- RoHS compliant

### 1.3.3D pSLC

3D Pseudo SLC can be considered as an extended version of 3D TLC. While 3D TLC does Full Sequence Programming into 8 Vth distribution, 3D pSLC only does Lower page programming into 2 Vth distribution. Accordingly, because only Lower pages are programmed, 3D pSLC provides better performance and endurance than 3D TLC. Moreover, 3D pSLC performs similarly with SLC, yet 3D pSLC is more cost-effective.

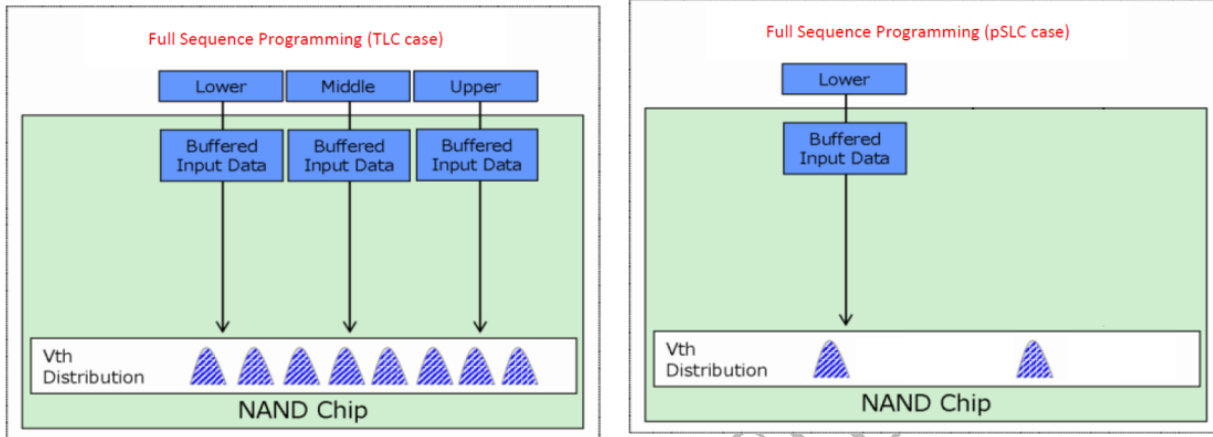

FLEXIXON CONFIDENTIAL

## 2. PRODUCT SPECIFICATIONS



### 2.1. Performance

Table 2-1 eMMC Performance

Density	Sequential Read (MB/s)	Sequential Write (MB/s)
8GB	315	215
16GB	315	215
32GB	315	225
64GB	315	240

Notes:

1. 8-bit bus width; HS400 mode; Vcc = 3.3V, VccQ = 1.8V
2. Performance may differ according to flash configuration and platform.

### 2.2. Power Consumption

Table 2-2 eMMC Power Consumption

Capacity	Read (mA)		Write (mA)		Standby (mA)
	VccQ	Vcc	VccQ	Vcc	
8GB	155	100	70	65	0.15
16GB	155	100	70	65	0.15
32GB	155	105	70	105	0.15
64GB	155	110	80	165	0.15

Notes:

1. 8-bit bus width; clock frequency of 200MHz DDR mode; Vcc = 3.3V, VccQ = 1.8V
2. Standby current is measured at Vcc = 3.3V, 8-bit bus width without clock frequency.

### 2.3. Partition Capacity

Table 2-3 eMMC Partition Capacity

Capacity	Boot Partition 1	Boot Partition 2	RPMB
8GB	4096 KB	4096 KB	4096 KB
16GB	4096 KB	4096 KB	4096 KB
32GB	4096 KB	4096 KB	4096 KB
64GB	4096 KB	4096 KB	4096 KB

### 3. INTERFACE DESCRIPTION



#### 3.1. FLEXXON eMMC I/F Ball Array

	A	B	C	D	E	F	G	H	J	K	L	M	N	P	
14	NC	NC	NC	NC	NC	NC	NC	NC	NC	NC	NC	NC	NC	NC	14
13	NC	NC	NC	NC	NC	NC	NC	NC	NC	NC	NC	NC	NC	NC	13
12	NC	NC	NC	NC	NC	NC	NC	NC	NC	NC	NC	NC	NC	NC	12
11	NC	NC	NC									NC	NC	NC	11
10	NC	NC	NC		NC	NC	NC	VSS	VCC	NC		NC	NC	NC	10
9	NC	NC	NC		NC					VCC		NC	NC	NC	9
8	NC	NC	NC		NC					VSS		NC	NC	NC	8
7	NC	NC	NC		VSS					NC		NC	NC	NC	7
6	VSS	DAT7	VCCQ		VCC					NC		CLK	NC	VSSQ	6
5	DAT2	DAT6	NC		NC	VCC	VSS	DS	VSS	RST_n		CMD	VSSQ	VCCQ	5
4	DAT1	DAT5	VSSQ	NC								VCCQ	VCCQ	VSSQ	4
3	DAT0	DAT4	NC	NC	NC	NC	NC	NC	NC	NC	NC	NC	NC	VCCQ	3
2	NC	DAT3	VDDi	NC	NC	NC	NC	NC	NC	NC	NC	NC	VSSQ	NC	2
1	NC	NC	NC	NC	NC	NC	NC	NC	NC	NC	NC	NC	NC	NC	1
	A	B	C	D	E	F	G	H	J	K	L	M	N	P	

Figure 3-1 eMMC interface in 153Balls Array (Top View)

FLEXXON

## 3.2. Pins and Signal Description

Table 3-1 Function Pin Assignment, 153 balls

eMMC Interface			
Ball No.	Ball Signal	Type	Description
A3	DAT0	I/O/PP	Data I/O: Bidirectional channel used for data transfer
A4	DAT1		
A5	DAT2		
B2	DAT3		
B3	DAT4		
B4	DAT5		
B5	DAT6		
B6	DAT7		
M5	CMD	I/O/PP	Command: A bidirectional channel used for device initialization and command transfers.
M6	CLK	Input	Clock: Each cycle directs a 1-bit transfer on the command and DAT lines
K5	RST_n	Input	Hardware Reset
E6	VCC	Supply	Supply Voltage for Core
F5	VCC		
J10	VCC		
K9	VCC		
C6	VCCQ	Supply	Supply Voltage for I/O
M4	VCCQ		
N4	VCCQ		
P3	VCCQ		
P5	VCCQ		
A6	VSS	Supply	Supply Voltage ground for Core
E7	VSS		
G5	VSS		
H10	VSS		
J5	VSS		
K8	VSS		
C4	VSSQ	Supply	Supply Voltage ground for I/O
N2	VSSQ		
N5	VSSQ		
P4	VSSQ		
P6	VSSQ		
H5	DS	O/PP	Data strobe
C2	VDDi		Connect capacitor from VDDi to GND for stabilize internal power.

**Note:**

NC: No connect in eMMC. Left it floating

## 4. EMMC REGISTERS



### 4.1. OCR Register

The 32-bit Operation Conditions Register (OCR) stores the VDD voltage profile of the Device and the access mode indication. The OCR register should be implemented by all Device.

Table 4-1 OCR Register Table

OCR slice	Description	Value	Width
[31]	Card power up status bit (busy) <sup>1</sup>		
[30:29]	Access mode	00b (byte mode) 10b (sector mode)	2
[28:24]	Reserved	0 0000b	5
[23:15]	2.7 - 3.6V	1 1111 1111b	9
[14:8]	2.0 - 2.6V	000 0000b	7
[7]	1.7 - 1.95V	1b	1
[6:0]	Reserved	000 0000b	7

Note <sup>1</sup>: This bit is set to Low if the Device has not finished the power up routine

### 4.2. CID Register

The Card Identification (CID) register is 128 bits wide. It contains the Device identification information used during the Device identification phase. For details, refer to JEDEC Standard Specification No. JESD84-B51.

Table 4-2 CID Register Table

Name	Field	CID Slice	Value	Width
Manufacturer ID	MID	[127:120]	EBh	8
Reserved	-	[119:114]	0h	6
Device/BGA	CBX	[113:112]	1h	2
OEM/ Application ID	OID	[111:104]	0Dh	8
Product Name	PNM	[103:56]	eMMC	48
Product Revision	PRV	[55:48]	51h	8
Product Serial Number	PSN	[47:16]	Random by Production	32
Manufacturing Date	MDT	[15:8]	Month, Year	8
CRC7 Checksum	CRC	[7:1]	-	7
Not used, always "1"	-	[0:0]	1h	1

### 4.3. CSD Register

The Device-Specific Data (CSD) register provides information on how to access the contents. The CSD defines the data format, error correction type, maximum data access time, data transfer speed, etc. For details, refer to JEDEC Standard Specification No. JESD84-B51.

**Table 4-3 CSD Register Table**

Name	Field	Width	Type	CSD	Value
CSD structure	CSD_STRUCTURE	2	R	[127:126]	3h
System specification version	SPEC_VERS	4	R	[125:122]	4h
Reserved	-	2	R	[121:120]	0h
Data read access-time 1	TAAC	8	R	[119:112]	4Fh
Data read access-time 2 in CLK cycles (NSAC*100)	NSAC	8	R	[111:104]	1h
Max. bus clock frequency	TRAN_SPEED	8	R	[103:96]	32h
Device command classes	CCC	12	R	[95:84]	8F5h
Max. read data block length	READ_BL_LEN	4	R	[83:80]	9h
Partial blocks for read allowed	READ_BL_PARTIAL	1	R	[79:79]	0h
Write block misalignment	WRITE_BLK_MISALIG	1	R	[78:78]	0h
Read block misalignment	READ_BLK_MISALIGN	1	R	[77:77]	0h
DSR implemented	DSR_IMP	1	R	[76:76]	0h
Reserved	-	2	R	[75:74]	0h
Device size	C_SIZE	12	R	[73:62]	FFFh
Max. read current @ VDD min	VDD_R_CURR_MIN	3	R	[61:59]	7h
Max. read current @ VDD max	VDD_R_CURR_MAX	3	R	[58:56]	7h
Max. write current @ VDD min	VDD_W_CURR_MIN	3	R	[55:53]	7h
Max. write current @ VDD max	VDD_W_CURR_MAX	3	R	[52:50]	7h
Device size multiplier	C_SIZE_MULT	3	R	[49:47]	7h
Erase group size	ERASE_GRP_SIZE	5	R	[46:42]	1Fh
Erase group size multiplier	ERASE_GRP_MULT	5	R	[41:37]	1Fh
Write protect group size	WP_GRP_SIZE	5	R	[36:32]	0Fh
Write protect group enable	WP_GRP_ENABLE	1	R	[31:31]	1h
Manufacturer default ECC	DEFAULT_ECC	2	R	[30:29]	0h
Write speed factor	R2W_FACTOR	3	R	[28:26]	2h
Max. write data block length	WRITE_BL_LEN	4	R	[25:22]	9h
Partial blocks for write allowed	WRITE_BL_PARTIAL	1	R	[21:21]	0h
Reserved	-	4	R	[20:17]	0h
Content protection application	CONTENT_PROT_APP	1	R	[16:16]	0h
File format group	FILE_FORMAT_GRP	1	R/W	[15:15]	0h
Copy flag (OTP)	COPY	1	R/W	[14:14]	0h
Permanent write protection	PERM_WRITE_PROTE	1	R/W	[13:13]	0h
Temporary write protection	TMP_WRITE_PROTEC	1	R/W/E	[12:12]	0h
File format	FILE_FORMAT	2	R/W	[11:10]	0h
ECC code	ECC	2	R/W/E	[9:8]	0h
CRC	CRC	7	R/W/E	[7:1]	2Eh
Not used, always '1'	-	1	-	[0:0]	1h

## 4.4. Extended CSD Register

The Extended CSD register defines the Device properties and selected modes. It is 512 bytes long. The most significant 320 bytes are the Properties segment, which defines the Device capabilities and cannot be modified by the host. The lower 192 bytes are the Modes segment, which defines the configuration the Device is working in. These modes can be changed by the host by means of the SWITCH command. For details, refer to JEDEC Standard Specification No. JESD84-B51.

## 4.5. RCA Register

The writable 16-bit Relative Device Address (RCA) register carries the Device address assigned by the host during the Device identification. This address is used for the addressed host-Device communication after the Device identification procedure. The default value of the RCA register is 0x0001. The value 0x0000 is reserved to set all Devices into the *Stand-by State* with CMD7.

## 4.6. DSR Register

The 16-bit driver stage register (DSR) is described in detail in JEDEC Standard Specification, JESD84-B51 Section 7.6. It can be optionally used to improve the bus performance for extended operating conditions (depending on parameters like bus length, transfer rate or number of Devices). The CSD register carries the information about the DSR register usage. The default value of the DSR register is 0x404.

## 5. ELECTRICAL CHARACTERISTICS



### 5.1. Power Supply

Table 5-1 eMMC power supply

Parameter	Symbol	Min	Max	Unit
Supply voltage (NAND)	Vcc	2.7	3.6	V
Supply voltage (I/O)	Vccq	2.7	3.6	V
		1.7	1.95	V
Supply Power-Up for 1.8V	tPRUL		25	ms
Supply Power-Up for 3.3V	tPRUH		35	ms

### 5.2. Bus Signal Levels

Figure 5-1 Bus Signal Levels

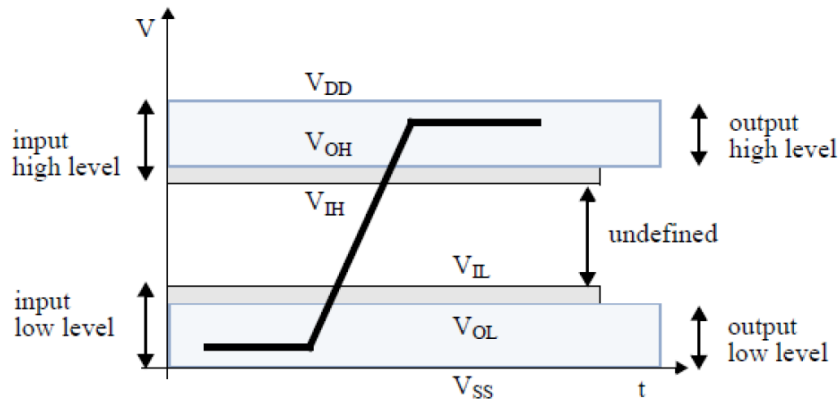
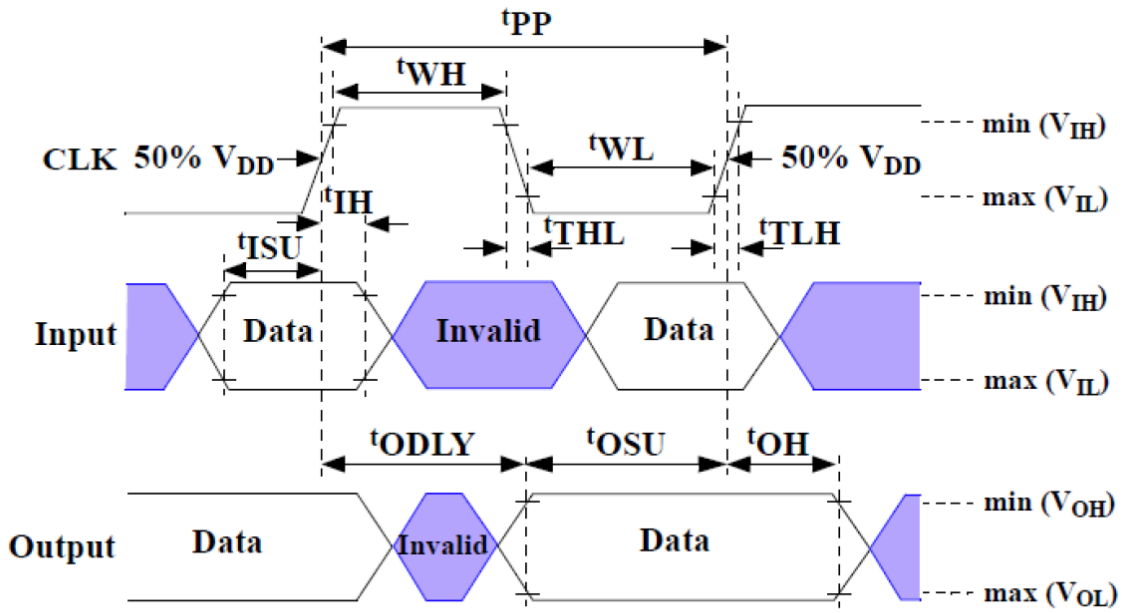

Table 5-2 Bus Signals Levels

Parameter	Symbol	Min	Max	Unit	Remark
<b>Open-Drain Bus Signal Level</b>					
Output High Voltage	VOH	VDD - 0.2	-	V	IOH = -100 uA
Output Low Voltage	VOL	-	0.3	V	IOL = 2 mA
<b>Push-pull bus signal level (2.7V~3.6V)</b>					
Output High Voltage	VOH	0.75 * VCCQ	-	V	IOH = -100 uA @ Vccq min
Output Low Voltage	VOL	-	0.125 * VCCQ	V	IOL = 100 uA @ Vccq min
Input High Voltage	VIH	0.625 * VCCQ	VCCQ + 0.3	V	
Input Low Voltage	VIL	VSS - 0.3	0.25 * VCCQ	V	
<b>Push-pull bus signal level (1.7V~1.95V)</b>					
Output High Voltage	VOH	VCCQ - 0.45V	-	V	IOH = -2 mA
Output Low Voltage	VOL	-	0.45V	V	IOL = 2 mA
Input High Voltage	VIH	0.65 * VCCQ	VCCQ + 0.3	V	
Input Low Voltage	VIL	VSS - 0.3	0.35 * VDD	V	

### 5.3. Bus Timing

Figure 5-2 Bus Timing in Single Data Rate Mode



Data must always be sampled on the rising edge of the clock.

FLEXION.COM

**Table 5-3 Backward Compatible Device Interface Timing**

Parameter	Symbol	Min	Max	Unit	Remark <sup>1</sup>
<b>Clock CLK<sup>2</sup></b>					
Clock Frequency Data Transfer Mode (PP) <sup>3</sup>	f <sub>PP</sub>	0	26	MHz	CL ≤ 30 pF
Clock Frequency Identification Mode (OD)	f <sub>OD</sub>	0	400	kHz	
Clock high time	t <sub>WH</sub>	10	-	ns	CL ≤ 30 pF
Clock low time	t <sub>WL</sub>	10	-	ns	CL ≤ 30 pF
Clock rise time <sup>4</sup>	t <sub>T<sub>TLH</sub></sub>	-	10	ns	CL ≤ 30 pF
Clock fall time	t <sub>T<sub>THL</sub></sub>	-	10	ns	CL ≤ 30 pF
<b>Inputs/Outputs CMD, DAT (Referenced to CLK)</b>					
Input set-up time	t <sub>ISU</sub>	3	-	ns	CL ≤ 30 pF
Input hold time	t <sub>IH</sub>	3	-	ns	CL ≤ 30 pF
Output set-up time <sup>5</sup>	t <sub>OSU</sub>	11.7	-	ns	CL ≤ 30 pF
Output hold time <sup>5</sup>	t <sub>OH</sub>	8.3	-	ns	CL ≤ 30 pF

Note <sup>1</sup>: The Device must always start with the backward-compatible interface timing. The timing mode can be switched to high-speed interface timing by the host sending the SWITCH command (CMD6) with the argument for high-speed interface select.

Note <sup>2</sup>: CLK timing is measured at 50% of VDD.

Note <sup>3</sup>: For compatibility with Devices that support the v4.2 standard or earlier, host should not use > 26 MHz before switching to high-speed interface timing.

Note <sup>4</sup>: CLK rise and fall times are measured by min (VIH) and max (VIL).

Note <sup>5</sup>: t<sub>OSU</sub> and t<sub>OH</sub> are defined as values from clock rising edge. However, there may be Devices or devices which utilize clock falling edge to output data in backward compatibility mode. Therefore, it is recommended for hosts either to set t<sub>WL</sub> value as long as possible within the range which will not go over t<sub>CK</sub>-t<sub>OH</sub>(min) in the system or to use slow clock frequency, so that host could have data set up margin for those devices. In this case, each device which utilizes clock falling edge might show the correlation either between t<sub>WL</sub> and t<sub>OSU</sub> or between t<sub>CK</sub> and t<sub>OSU</sub> for the device in its own datasheet as a note or its' application notes.

**Table 5-4 High Speed Device Interface Timing**

Parameter	Symbol	Min	Max	Unit	Remark
<b>Clock CLK<sup>1</sup></b>					
Clock Frequency Data Transfer Mode (PP) <sup>2</sup>	f <sub>PP</sub>	0	52 <sup>3</sup>	MHz	CL ≤30 pF Tolerance:+ 100 KHz
Clock Frequency Identification Mode (OD)	f <sub>OD</sub>	0	400	kHz	Tolerance: +20 KHz
Clock high time	t <sub>WH</sub>	6.5	-	ns	CL ≤30 pF
Clock low time	t <sub>WL</sub>	6.5	-	ns	CL ≤30 pF
Clock rise time <sup>4</sup>	t <sub>TLH</sub>	-	3	ns	CL ≤30 pF
Clock fall time	t <sub>THL</sub>	-	3	ns	CL ≤30 pF
<b>Inputs /Outputs CMD, DAT (Referenced to CLK)</b>					
Input set-up time	t <sub>ISU</sub>	3	-	ns	CL ≤30 pF
Input hold time	t <sub>IH</sub>	3	-	ns	CL ≤30 pF
Output delay time during data transfer	t <sub>ODLY</sub>	-	13.7	ns	CL ≤30 pF
Output hold time	t <sub>OH</sub>	2.5	-	ns	CL ≤30 pF
Signal rise time <sup>5</sup>	t <sub>RISE</sub>	-	3	ns	CL ≤30 pF
<p>Note <sup>1</sup>: CLK timing is measured at 50% of VDD.</p> <p>Note <sup>2</sup>: eMMC shall support the full frequency range from 0-26Mhz, or 0-52MHz</p> <p>Note <sup>3</sup>: Device can operate as high-speed Device interface timing at 26 MHz clock frequency.</p> <p>Note <sup>4</sup>: CLK rise and fall times are measured by min (VIH) and max (VIL).</p> <p>Note <sup>5</sup>: Inputs CMD, DAT rise and fall times are measured by min (VIH) and max (VIL), and output CMD, DAT rise and fall times are measured by min (VOH) and max (VOL).</p>					

**Figure 5-3 Bus Timing in Dual Data Rate Mode**

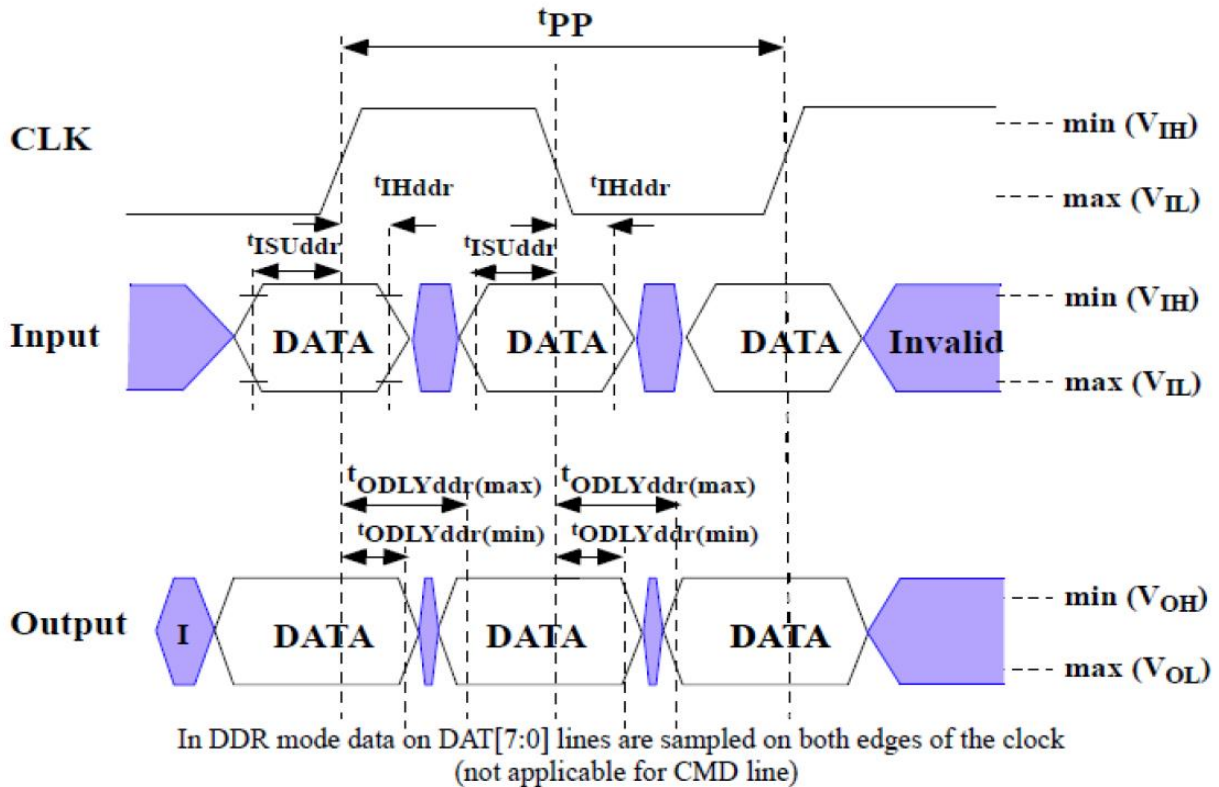

**Table 5-5 Dual Data Rate Interface Timing**

Parameter	Symbol	Min	Max	Unit	Remark
<b>Input CLK<sup>1</sup></b>					
Clock Duty Cycle	-	45	55	%	Include jitter, phase noise
<b>Input/Output DAT (Referenced to CLK-DDR Mode)</b>					
Input set-up time	t <sub>ISUddr</sub>	2.5	-	ns	CL ≤20 pF
Input hold time	t <sub>IHddr</sub>	2.5	-	ns	CL ≤20 pF
Output delay time	t <sub>ODLYddr</sub>	1.5	7	ns	CL ≤20 pF
Signal rise time (DAT0-7) <sup>2</sup>	t <sub>RISE</sub>	-	2	ns	CL ≤20 pF
Signal fall time (DAT0-7)	t <sub>FALL</sub>	-	2	ns	CL ≤20 pF
Note <sup>1</sup> : CLK timing is measured at 50% of VDD.					
Note <sup>2</sup> : Inputs DAT rise and fall times are measured by min (VIH) and max (VIL), and outputs DAT rise and fall times are measured by min (VOH) and max (VOL).					

**Figure 5-4 HS200 Clock Signal Timing**

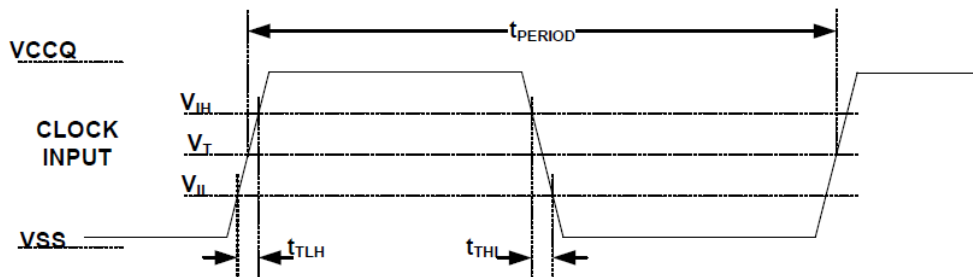

Notes:

1. VIH denote VIH(min.) and VIL denotes VIL(max.).
2. VT=0.975V – Clock Threshold, indicates clock reference point for timing measurements.

**Table 5-6 HS200 Clock Signal Timing**

Symbol	Min	Max	Unit	Remark
t <sub>PERIOD</sub>	5	-	ns	200MHz (Max.), between rising edges
t <sub>TLH</sub> , t <sub>THL</sub>	-	0.2* t <sub>PERIOD</sub>	ns	t <sub>TLH</sub> , t <sub>THL</sub> < 1ns (max.) at 200MHz, C <sub>DEVICE</sub> =6pF, The absolute maximum value of t <sub>TLH</sub> , t <sub>THL</sub> is 10ns regardless of clock frequency.
Duty Cycle	30	70	%	

Figure 5-5 HS200 Device Input Timing

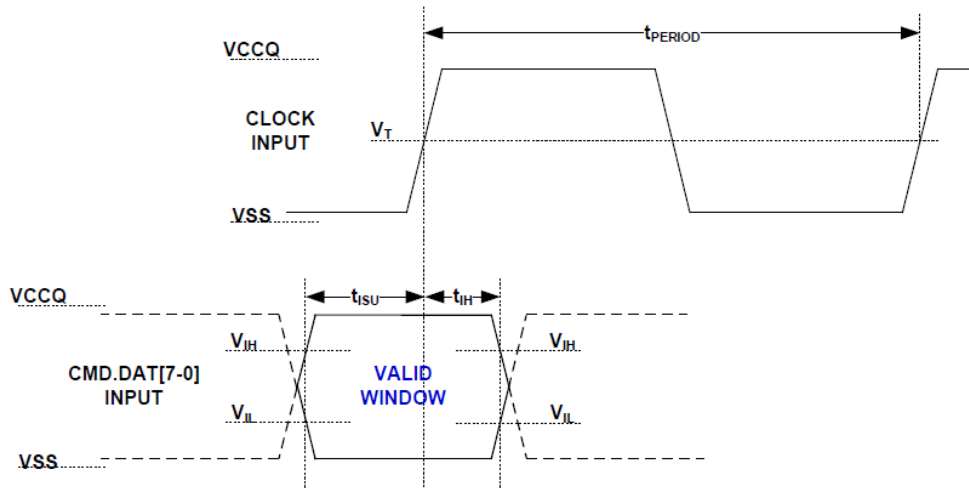

Note 1:  $t_{ISU}$  and  $t_{IH}$  are measured at  $V_{IL}$  (max) and  $V_{IH}$  (min).

Note 2:  $V_{IH}$  denote  $V_{IH}$  (min) and  $V_{IL}$  (max) denotes  $V_{IL}$  (max).

Table 5-7 HS200 Device Input Timing

Symbol	Min	Max	Unit	Remark
$t_{ISU}$	1.40	-	ns	$C_{DEVICE} \leq 6pF$
$t_{IH}$	0.8	-	ns	$C_{DEVICE} \leq 6pF$

**Figure 5-6 HS200 Device Output Timing**

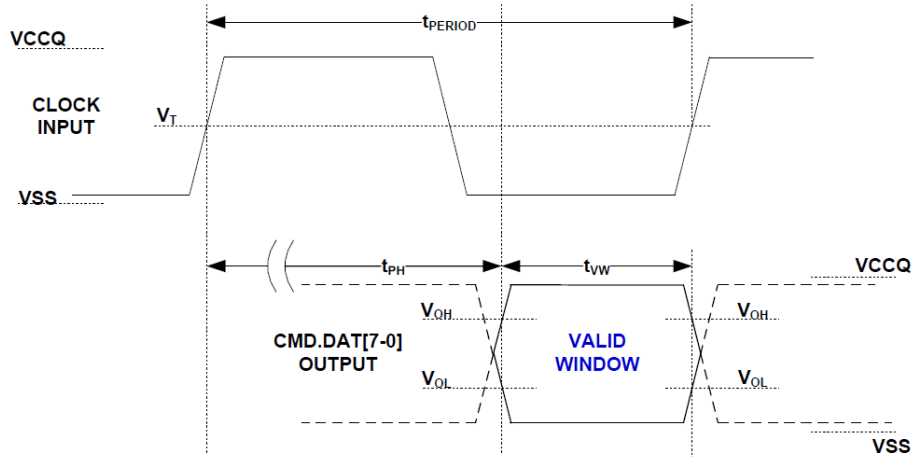

NOTE  $V_{OH}$  denotes  $V_{OH(min.)}$  and  $V_{OL}$  denotes  $V_{OL(max.)}$ .

**Table 5-8 HS200 Device Output Timing**

Symbol	Min	Max	Unit	Remark
$t_{PH}$	0	2	UI	Device output momentary phase from CLK input to CMD or DAT lines output. Does not include a long term temperature drift.
$\Delta T_{PH}$	-350 ( $\Delta T = -20^\circ C$ )	+1550 ( $\Delta T = 90^\circ C$ )	ps	Delay variation due to temperature change after tuning. Total allowable shift of output valid window (TVW) from last system Tuning procedure $\Delta T_{PH}$ is 2600ps for $\Delta T$ from $-25^\circ C$ to $125^\circ C$ during operation.
$T_{vw}$	0.575	-	UI	$t_{vw} = 2.88ns$ at 200MHz Using test circuit including skew among CMD and DAT lines created by the Device. Host path may add Signal Integrity induced noise, skews, etc. Expected TVW at Host input is larger than 0.475UI.

Note: Unit Interval (UI) is one bit nominal time. For example, UI=5ns at 200MHz.

**Figure 5-7  $\Delta T_{PH}$  consideration**

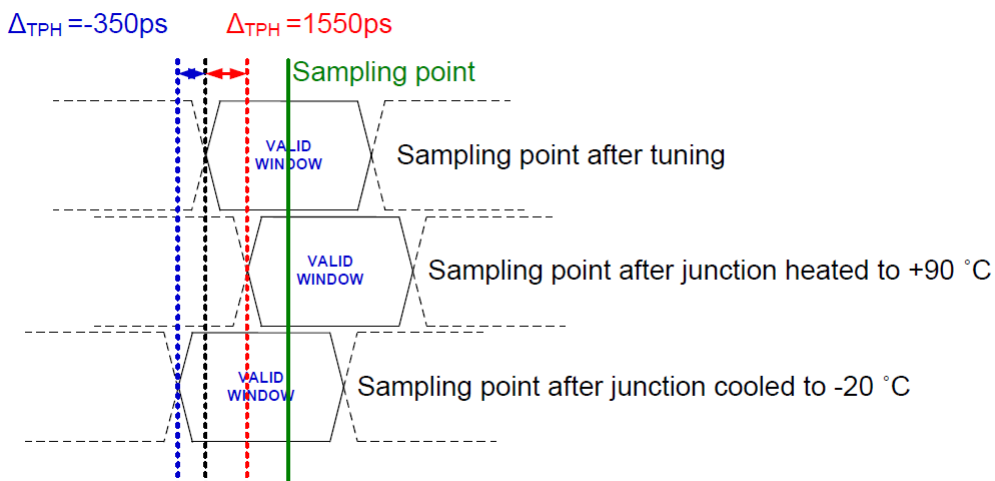

Figure 5-8 HS400 Device Input Timing

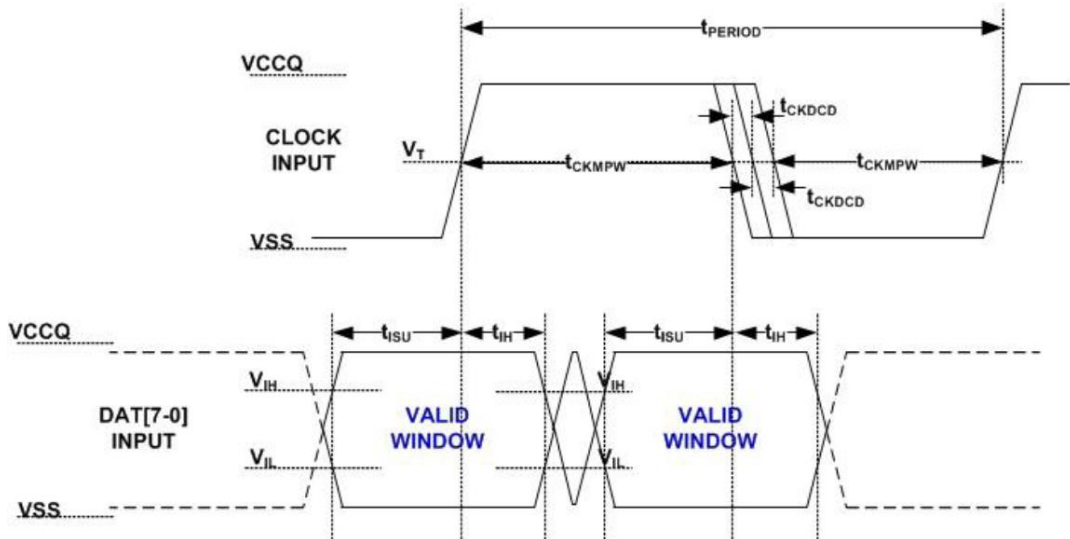

Table 5-9 HS400 Device Input Timing

Parameter	Symbol	Min	Max	Unit	Remark
<b>Input CLK</b>					
Cycle time data transfer mode	tPERIOD	5			200MHz (Max), between rising edges with respect to VT.
Slew rate	SR	1.125		V/ns	With respect to VIH/VIL.
Duty cycle distortion	tCKDCD	0	0.3	ns	Allowable deviation from an ideal 50% duty cycle. With respect to VT. Includes jitter, phase noise.
Minimum pulse width	tCKMPW	2.2		ns	With respect to VT.
<b>Input DAT (referenced to CLK)</b>					
Input set-up time	tISUddr	0.4	-	ns	Cdevice ≤ 6pF with respect to VIH/VIL.
Input hold time	tIHddr	0.4	-	ns	Cdevice ≤ 6pF with respect to VIH/VIL.
Slew rate	SR	1.125		V/ns	with respect to VIH/VIL.

Figure 5-9 HS400 Device Output Timing

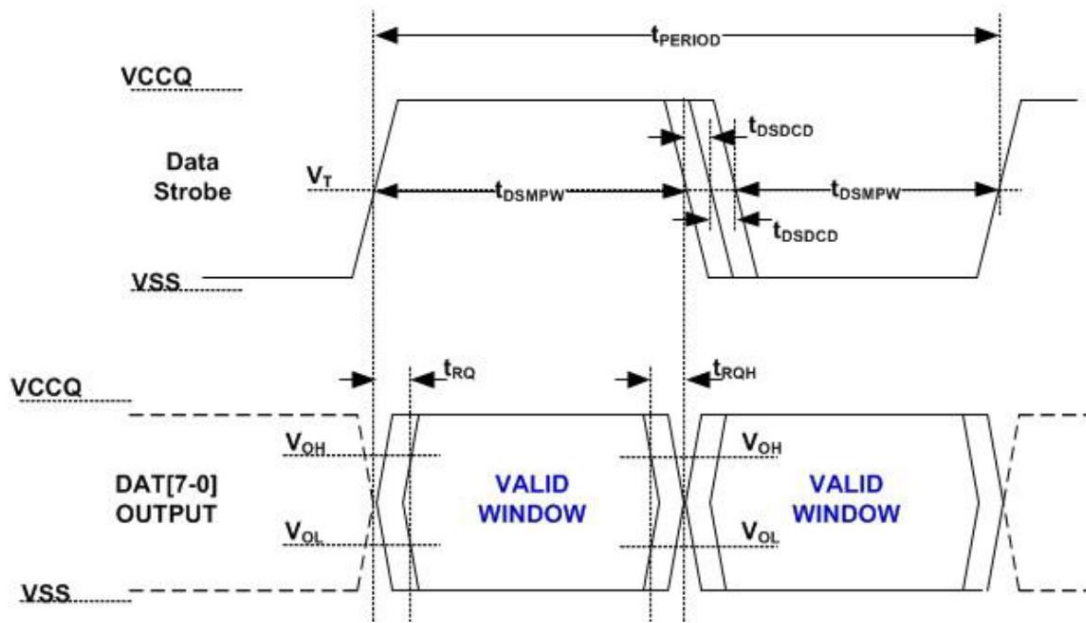

Table 5-10 HS400 Device Output Timing

Parameter	Symbol	Min	Max	Unit	Remark
<b>Data Strobe</b>					
Cycle time data transfer mode	$t_{PERIOD}$	5			200MHz(Max), between rising edges with respect to $V_T$ .
Slew rate	SR	1.125		V/ns	With respect to $V_{OH}/V_{OL}$ and HS400 reference load
Duty cycle distortion	$t_{DSDCD}$	0	0.2	ns	Allowable deviation from an input CLK duty cycle distortion ( $t_{CKDCD}$ ). With respect to $V_T$ . Includes jitter, phase noise
Minimum pulse width	$t_{DSMPW}$	2		ns	With respect to $V_T$ .
Read pre-amble	$t_{RPRE}$	0.4		$t_{PERIOD}$	Max value is specified by manufacture. Value up to infinite is valid
Read post-amble	$t_{RPST}$	0.4		$t_{PERIOD}$	Max value is specified by manufacture. Value up to infinite is valid
<b>Output DAT (Referenced to Data Strobe)</b>					
Slew rate	SR	1.125		V/ns	With respect to $V_{OH}/V_{OL}$ and HS400 reference load.

**Table 5-11 HS400 Capacitance**

Parameter	Symbol	Min	Type	Max	Unit
Pull-up resistance for CMD	RCMD	4.7		50	Kohm
Pull-up resistance for DAT0-7	RDAT	10		50	Kohm
Pull-down resistance for Data Strobe	RDS	10		50	Kohm
Internal pull up resistance DAT1-DAT7	R <sub>int</sub>	10		150	Kohm
Bus signal line capacitance	CL			13	pF
Single Device capacitance	C <sub>device</sub>			6	pF

FLEXON CONFIDENTIAL

## 6. PACKAGE



Package Size: 11.5 x 13.0 x 1.0mm

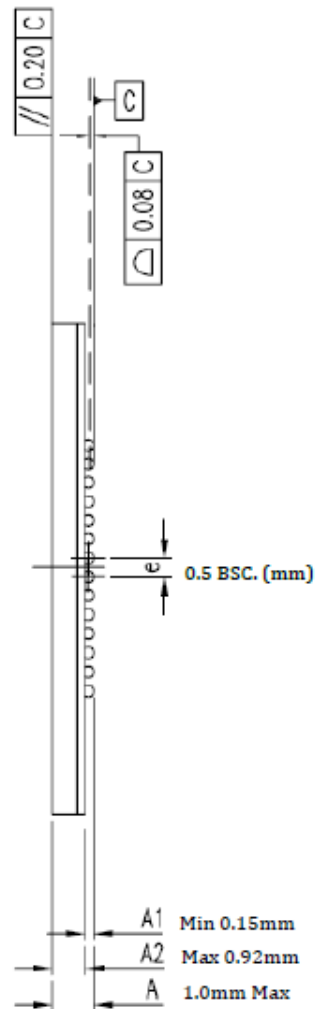
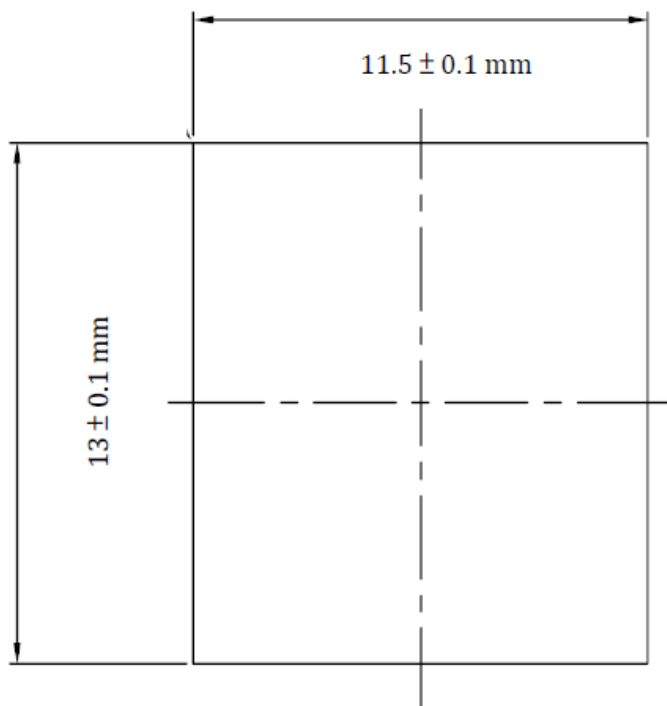

FLEXA

VAL

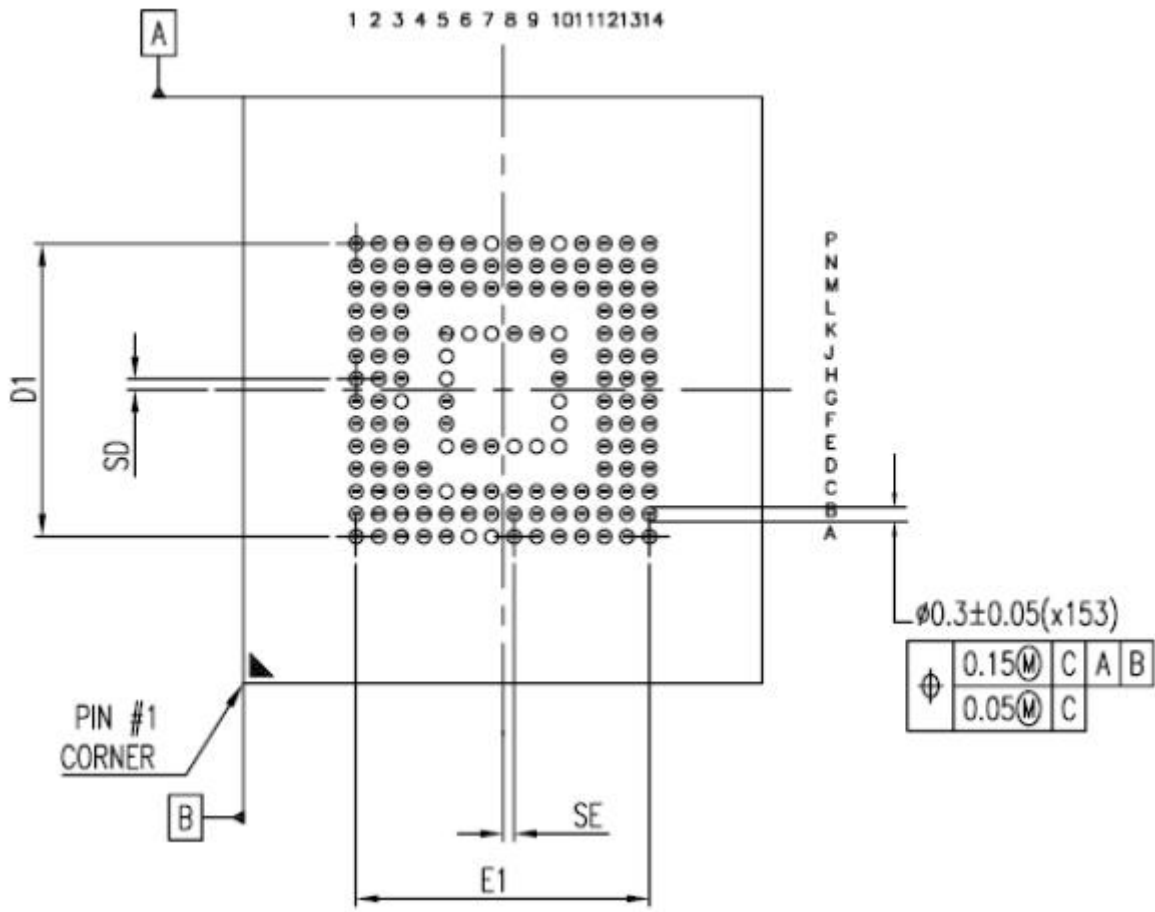

Bottom View:

N	SE (MM)	SD (MM)	E1 (MM)	D1 (MM)	JEDEC (REF)
153	0.25 BSC.	0.25 BSC.	6.50 BSC.	6.50 BSC.	MO-276 BA

FLEXION

## 7. ORDERING INFORMATION



Capacity	MPN (Gold Grade)	Power System	Pin Configuration	Package Size
8GB	FEMC008GCG-T34N	VCCQ: 1.8V/3.3V VCC: 3.3V	153 FBGA	11.5x13x1.0 (mm)
16GB	FEMC016GCG-T34N			
32GB	FEMC032GCG-T34N			
64GB	FEMC064GCG-T34N			

FLEXION CONFIDENTIAL

## Revision History

Revision	Release Date	History
1.0	2019/10	First release
1.1	2020/03	Update eMMC Registers
1.2	2020/06	Update Product overview, Product Specification, Pin and signal description and ordering information.
1.3	2020/08	Add Partition Capacity
1.4	2020/10	Update VCCQ in Power supply
1.5	2021/05	Update ordering information.
1.6	2023/03	Update product specification and ordering information

FLEXION CONFIDENTIAL