



eMMC Specification

(XTRA VIII Series, 153ball)

3D TLC

Version 1.1

Address: 28 Genting Lane, #09-03/04/05 Platinum 28, Singapore 349585

Tel : +65-6493 5035

Fax : +65-6493 5037

Website: <http://www.flexxon.com>

Email: flexxon@flexxon.com

ALL RIGHTS ARE STRICTLY RESERVED. ANY PORTION OF THIS PAPER SHALL NOT BE REPRODUCED, COPIED, OR TRANSLATED TO ANY OTHER FORMS WITHOUT PERMISSION FROM FLEXXON.

TABLE OF CONTENTS

1.	General Description.....	3
1.1.	Introduction	3
1.2.	Product Overview	3
2.	Product Specifications	4
2.1.	Performance	4
2.2.	Power Consumption	4
2.3.	Partition Capacity	5
3.	interface description	6
3.1.	FLEXXON eMMC I/F Ball Array.....	6
3.2.	Pins and Signal Description.....	7
4.	emmc registers.....	8
4.1.	OCR Register.....	8
4.2.	CID Register	8
4.3.	CSD Register	9
4.4.	Extended CSD Register.....	10
4.5.	RCA Register.....	10
4.6.	DSR Register	10
5.	Electrical characteristics	11
5.1.	Power Supply.....	11
5.2.	Bus Signal Levels	11
5.3.	Bus Timing	12
6.	Package	20
7.	ORDERING INFORMATION	22

1. GENERAL DESCRIPTION



1.1. Introduction

FLEXXON's XTRA VIII eMMC is fully comply with JEDEC eMMC5.1 Standard. It is combined of an embedded flash controller and 3D NAND flash memory in one JEDEC standard package, 153Balls (11.5mm x 13mm). FLEXXON eMMC provides high performance, good reliability and advanced power management. It is fully comply with AEC-Q100 Grade 3 & Grade 2 and TS16949 and is suitable for Automotive Applications.

1.2. Product Overview

FLEXXON XTRA VIII eMMC 5.1 includes the following features:

- Compliant with eMMC Specification Ver. 4.3, 4.4, 4.5, 5.0, 5.1
- Flash Type:
 - 3D TLC: 16GB ~ 256GB
- Package of eMMC
 - 11.5 mm x 13 mm x 1.0 mm
- Temperature Range
 - Operation & Storage (Automotive Grade 3): -40°C ~ 85°C
 - Operation & Storage (Automotive Grade 2): -40°C ~ 105°C
- Operating Voltage
 - VCC (Automotive Grade 3 & 2): 3.3V
 - VCCQ (Automotive Grade 3): 1.8V/3.3V
 - VCCQ (Automotive Grade 2): 1.8V
- Bus Mode
 - High-speed eMMC protocol
 - Clock frequency: 0 ~ 200MHz
- Supports three data bus widths: 1 bit (default), 4 bits, 8 bits
- Supports High Speed Mode HS400
- Supports Production State Awareness
- Supports Field Firmware Update
- Supports Power Off Notification
- Support Enhanced Data Strobe
- Support Secure Write Protection
- RoHS compliant

2. PRODUCT SPECIFICATIONS



2.1. Performance

Table 2-1 eMMC Maximum Performance (Automotive Grade 3 & 2)

Density	Sequential Read (MB/s)	Sequential Write (MB/s)
16GB	320	135
32GB	320	130
64GB	320	240
128GB	320	245
256GB	320	260

Notes:

1. 8-bit bus width; HS400 mode; $V_{cc} = 3.3V$, $V_{ccq} = 1.8V$
2. Performance may differ according to flash configuration and platform.

2.2. Power Consumption

Table 2-2 eMMC Power Consumption RMS (Automotive Grade 3)

Capacity	Read (mA)		Write (mA)		Standby (mA)
	I _{ccq}	I _{cc}	I _{ccq}	I _{cc}	
16GB	160	100	80	50	0.14
32GB	160	100	80	50	0.14
64GB	170	120	80	75	0.14
128GB	170	125	85	110	0.14
256GB	170	135	95	190	0.14

Table 2-3 eMMC Power Consumption RMS (Automotive Grade 2)

Capacity	Read (mA)		Write (mA)		Standby (mA)
	I _{ccq}	I _{cc}	I _{ccq}	I _{cc}	
16GB	210	55	90	40	0.15
32GB	220	55	90	40	0.15
64GB	220	70	100	50	0.15
128GB	225	70	120	85	0.15
256GB	235	70	145	145	0.15

Notes:

1. RMS current is measured at $T_A=25^{\circ}C$, 8-bit bus width without clock frequency.
2. Performance of is measured at $V_{cc}=3.3V$, $V_{ccq}=1.8V$ in HS400 mode.
3. Current numbers might be subject to changes without notice.

2.3. Partition Capacity

Table 2-4 eMMC Partition Capacity

Capacity	Boot Partition 1	Boot Partition 2	RPMB
16GB	4096 KB	4096 KB	4096 KB
32GB	4096 KB	4096 KB	4096 KB
64GB	4096 KB	4096 KB	4096 KB
128GB	4096 KB	4096 KB	4096 KB
256GB	4096 KB	4096 KB	4096 KB

FLEXOXON CONFIDENTIAL

3. INTERFACE DESCRIPTION



3.1. FLEXXON eMMC I/F Ball Array

	A	B	C	D	E	F	G	H	J	K	L	M	N	P	
14	NC	NC	NC	NC	NC	NC	NC	NC	NC	NC	NC	NC	NC	NC	14
13	NC	NC	NC	NC	NC	NC	NC	NC	NC	NC	NC	NC	NC	NC	13
12	NC	NC	NC	NC	NC	NC	NC	NC	NC	NC	NC	NC	NC	NC	12
11	NC	NC	NC									NC	NC	NC	11
10	NC	NC	NC		NC	NC	NC	VSS	VCC	NC		NC	NC	NC	10
9	NC	NC	NC		NC					VCC		NC	NC	NC	9
8	NC	NC	NC		NC					VSS		NC	NC	NC	8
7	NC	NC	NC		VSS					NC		NC	NC	NC	7
6	VSS	DAT7	VCCQ		VCC					NC		CLK	NC	VSSQ	6
5	DAT2	DAT6	NC		NC	VCC	VSS	DS	VSS	RST_n		CMD	VSSQ	VCCQ	5
4	DAT1	DAT5	VSSQ	NC								VCCQ	VCCQ	VSSQ	4
3	DAT0	DAT4	NC	NC	NC	NC	NC	NC	NC	NC	NC	NC	NC	VCCQ	3
2	NC	DAT3	VDDi	NC	NC	NC	NC	NC	NC	NC	NC	NC	VSSQ	NC	2
1	NC	NC	NC	NC	NC	NC	NC	NC	NC	NC	NC	NC	NC	NC	1
	A	B	C	D	E	F	G	H	J	K	L	M	N	P	

Figure 3-1 eMMC interface in 153Balls Array (Top View)

FLEXON

3.2. Pins and Signal Description

Table 3-1 Function Pin Assignment, 153 balls

eMMC Interface			
Ball No.	Ball Signal	Type	Description
A3	DAT0	I/O/PP	Data I/O: Bidirectional channel used for data transfer
A4	DAT1		
A5	DAT2		
B2	DAT3		
B3	DAT4		
B4	DAT5		
B5	DAT6		
B6	DAT7		
M5	CMD	I/O/PP	Command: A bidirectional channel used for device initialization and command transfers.
M6	CLK	Input	Clock: Each cycle directs a 1-bit transfer on the command and DAT lines
K5	RST_n	Input	Hardware Reset
E6	VCC	Supply	Supply Voltage for Core
F5	VCC		
J10	VCC		
K9	VCC		
C6	VCCQ	Supply	Supply Voltage for I/O
M4	VCCQ		
N4	VCCQ		
P3	VCCQ		
P5	VCCQ		
A6	VSS	Supply	Supply Voltage ground for Core
E7	VSS		
G5	VSS		
H10	VSS		
J5	VSS		
K8	VSS		
C4	VSSQ	Supply	Supply Voltage ground for I/O
N2	VSSQ		
N5	VSSQ		
P4	VSSQ		
P6	VSSQ		
H5	DS	O/PP	Data strobe
C2	VDDi		Connect capacitor from VDDi to GND for stabilize internal power.

Note:

NC: No connect in eMMC. Left it floating.

4. EMMC REGISTERS



4.1. OCR Register

The 32-bit Operation Conditions Register (OCR) stores the VDD voltage profile of the Device and the access mode indication. The OCR register should be implemented by all Device.

Table 4-1 OCR Register Table

OCR slice	Description	Value	Width
[31]	Card power up status bit (busy) ¹		
[30:29]	Access mode	00b (byte mode) 10b (sector mode)	2
[28:24]	Reserved	0 0000b	5
[23:15]	2.7 - 3.6V	1 1111 1111b	9
[14:8]	2.0 - 2.6V	000 0000b	7
[7]	1.7 - 1.95V	1b	1
[6:0]	Reserved	000 0000b	7

Note ¹: This bit is set to Low if the Device has not finished the power up routine

4.2. CID Register

The Card Identification (CID) register is 128 bits wide. It contains the Device identification information used during the Device identification phase. For details, refer to JEDEC Standard Specification No. JESD84-B50.

Table 4-2 CID Register Table

Name	Field	CID Slice	Value	Width
Manufacturer ID	MID	[127:120]	EBh	8
Reserved	-	[119:114]	0h	6
Device/BGA	CBX	[113:112]	1h	2
OEM/ Application ID	OID	[111:104]	1h	8
Product Name	PNM	[103:56]	eMMC	48
Product Revision	PRV	[55:48]	51h	8
Product Serial Number	PSN	[47:16]	Random by Production	32
Manufacturing Date	MDT	[15:8]	Manufacturing date	8
CRC7 Checksum	CRC	[7:1]	CRC7	7
Not used, always "1"	-	[0:0]	1h	1

4.3. CSD Register

The Device-Specific Data (CSD) register provides information on how to access the contents. The CSD defines the data format, error correction type, maximum data access time, data transfer speed, etc. For details, refer to JEDEC Standard Specification No. JESD84-B51.

Table 4-3 CSD Register Table

Name	Field	Width	Type	CSD Slice	Value
CSD structure	CSD_STRUCTURE	2	R	[127:126]	3h
System specification version	SPEC_VERS	4	R	[125:122]	4h
Reserved	-	2	R	[121:120]	0h
Data read access-time 1	TAAC	8	R	[119:112]	4Fh
Data read access-time 2 in CLK cycles (NSAC*100)	NSAC	8	R	[111:104]	1h
Max. bus clock frequency	TRAN_SPEED	8	R	[103:96]	32h
Device command classes	CCC	12	R	[95:84]	8F5h
Max. read data block length	READ_BL_LEN	4	R	[83:80]	9h
Partial blocks for read allowed	READ_BL_PARTIAL	1	R	[79:79]	0h
Write block misalignment	WRITE_BLK_MISALIGN	1	R	[78:78]	0h
Read block misalignment	READ_BLK_MISALIGN	1	R	[77:77]	0h
DSR implemented	DSR_IMP	1	R	[76:76]	0h
Reserved	-	2	R	[75:74]	0h
Device size	C_SIZE	12	R	[73:62]	FFFh
Max. read current @ VDD min	VDD_R_CURR_MIN	3	R	[61:59]	7h
Max. read current @ VDD max	VDD_R_CURR_MAX	3	R	[58:56]	7h
Max. write current @ VDD min	VDD_W_CURR_MIN	3	R	[55:53]	7h
Max. write current @ VDD max	VDD_W_CURR_MAX	3	R	[52:50]	7h
Device size multiplier	C_SIZE_MULT	3	R	[49:47]	7h
Erase group size	ERASE_GRP_SIZE	5	R	[46:42]	1Fh
Erase group size multiplier	ERASE_GRP_MULT	5	R	[41:37]	1Fh
Write protect group size	WP_GRP_SIZE	5	R	[36:32]	0Fh
Write protect group enable	WP_GRP_ENABLE	1	R	[31:31]	1h
Manufacturer default ECC	DEFAULT_ECC	2	R	[30:29]	0h
Write speed factor	R2W_FACTOR	3	R	[28:26]	2h
Max. write data block length	WRITE_BL_LEN	4	R	[25:22]	9h
Partial blocks for write allowed	WRITE_BL_PARTIAL	1	R	[21:21]	0h
Reserved	-	4	R	[20:17]	0h
Content protection application	CONTENT_PROT_APP	1	R	[16:16]	0h
File format group	FILE_FORMAT_GRP	1	R/W	[15:15]	0h
Copy flag (OTP)	COPY	1	R/W	[14:14]	0h

Permanent write protection	PERM_WRITE_PROTECT	1	R/W	[13:13]	0h
Temporary write protection	TMP_WRITE_PROTECT	1	R/W/E	[12:12]	0h
File format	FILE_FORMAT	2	R/W	[11:10]	0h
ECC code	ECC	2	R/W/E	[9:8]	0h
CRC	CRC	7	R/W/E	[7:1]	2Eh
Not used, always '1'	-	1	-	[0:0]	1h

4.4. Extended CSD Register

The Extended CSD register defines the Device properties and selected modes. It is 512 bytes long. The most significant 320 bytes are the Properties segment, which defines the Device capabilities and cannot be modified by the host. The lower 192 bytes are the Modes segment, which defines the configuration the Device is working in. These modes can be changed by the host by means of the SWITCH command. For details, refer to JEDEC Standard Specification No. JESD84-B51.

4.5. RCA Register

The writable 16-bit Relative Device Address (RCA) register carries the Device address assigned by the host during the Device identification. This address is used for the addressed host-Device communication after the Device identification procedure. The default value of the RCA register is 0x0001. The value 0x0000 is reserved to set all Devices into the *Stand-by State* with CMD7.

4.6. DSR Register

The 16-bit driver stage register (DSR) is described in detail in JEDEC Standard Specification, JESD84-B51 Section 7.6. It can be optionally used to improve the bus performance for extended operating conditions (depending on parameters like bus length, transfer rate or number of Devices). The CSD register carries the information about the DSR register usage. The default value of the DSR register is 0x404.

5. ELECTRICAL CHARACTERISTICS



5.1. Power Supply

Table 5-1 eMMC power supply

Parameter	Symbol	Min	Max	Unit
Supply voltage (NAND)	Vcc	2.7	3.6	V
Supply voltage (I/O)	Vccq	2.7	3.6	V
		1.7	1.95	V
Supply Power-Up for 1.8V	tPRUL		25	ms
Supply Power-Up for 3.3V	tPRUH		35	ms

5.2. Bus Signal Levels

Figure 5-1 Bus Signal Levels

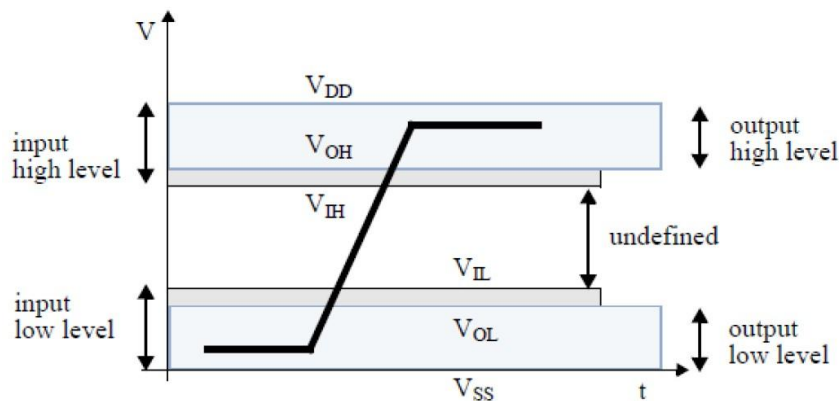
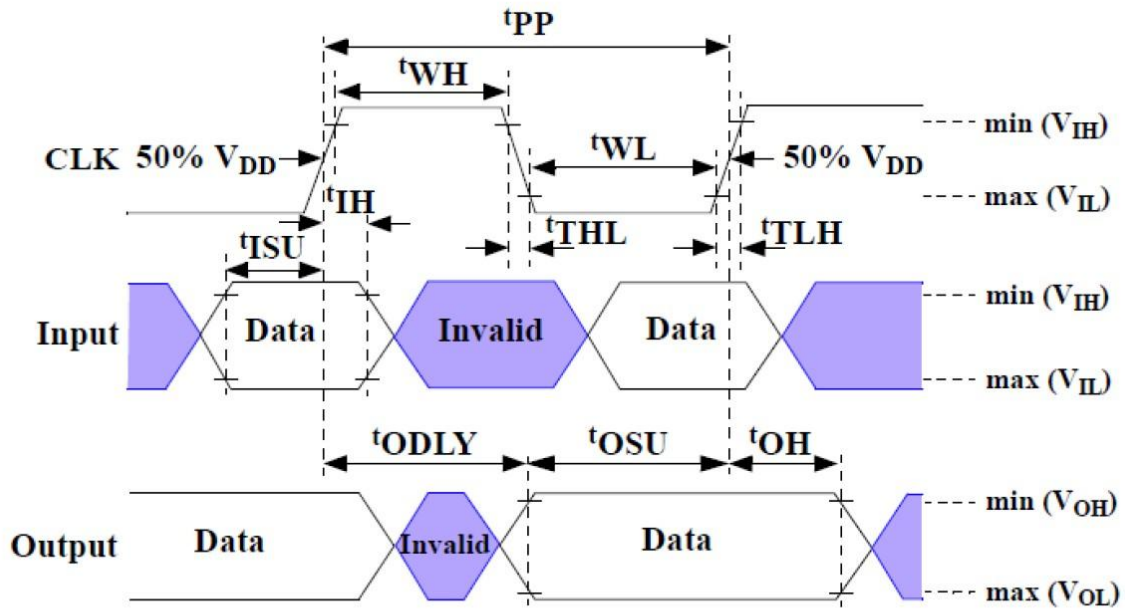

Table 5-2 Bus Signals Levels

Parameter	Symbol	Min	Max	Unit	Remark
Open-Drain Bus Signal Level					
Output High Voltage	VOH	VDD - 0.2	-	V	IOH = -100 uA
Output Low Voltage	VOL	-	0.3	V	IOL = 2 mA
Push-pull bus signal level (2.7V~3.6V)					
Output High Voltage	VOH	0.75 * VCCQ	-	V	IOH = -100 uA @ Vccq min
Output Low Voltage	VOL	-	0.125 * VCCQ	V	IOL = 100 uA @ Vccq min
Input High Voltage	VIH	0.625 * VCCQ	VCCQ + 0.3	V	
Input Low Voltage	VIL	VSS - 0.3	0.25 * VCCQ	V	
Push-pull bus signal level (1.7V~1.95V)					
Output High Voltage	VOH	VCCQ - 0.45V	-	V	IOH = -2 mA
Output Low Voltage	VOL	-	0.45V	V	IOL = 2 mA
Input High Voltage	VIH	0.65 * VCCQ	VCCQ + 0.3	V	
Input Low Voltage	VIL	VSS - 0.3	0.35 * VDD	V	

5.3. Bus Timing

Figure 5-2 Bus Timing in Single Data Rate Mode



Data must always be sampled on the rising edge of the clock.

FLEXIXON.COM

Table 5-3 High Speed Device Interface Timing

Parameter	Symbol	Min	Max	Unit	Remark
Clock CLK¹					
Clock Frequency Data Transfer Mode (PP) ²	f _{PP}	0	52 ³	MHz	CL ≤30 pF Tolerance:+ 100 KHz
Clock Frequency Identification Mode (OD)	f _{OD}	0	400	kHz	Tolerance: +20 KHz
Clock high time	t _{WH}	6.5	-	ns	CL ≤30 pF
Clock low time	t _{WL}	6.5	-	ns	CL ≤30 pF
Clock rise time ⁴	t _{TLH}	-	3	ns	CL ≤30 pF
Clock fall time	t _{THL}	-	3	ns	CL ≤30 pF
Inputs /Outputs CMD, DAT (Referenced to CLK)					
Input set-up time	t _{ISU}	3	-	ns	CL ≤30 pF
Input hold time	t _{IH}	3	-	ns	CL ≤30 pF
Output delay time during data transfer	t _{ODLY}	-	13.7	ns	CL ≤30 pF
Output hold time	t _{OH}	2.5	-	ns	CL ≤30 pF
Signal rise time ⁵	t _{RISE}	-	3	ns	CL ≤30 pF

Note ¹: CLK timing is measured at 50% of VDD.
 Note ²: eMMC shall support the full frequency range from 0-26Mhz, or 0-52MHz
 Note ³: Device can operate as high-speed Device interface timing at 26 MHz clock frequency.
 Note ⁴: CLK rise and fall times are measured by min (VIH) and max (VIL).
 Note ⁵: Inputs CMD, DAT rise and fall times are measured by min (VIH) and max (VIL), and output CMD, DAT rise and fall times are measured by min (VOH) and max (VOL).

Figure 5-3 Bus Timing in Dual Data Rate Mode

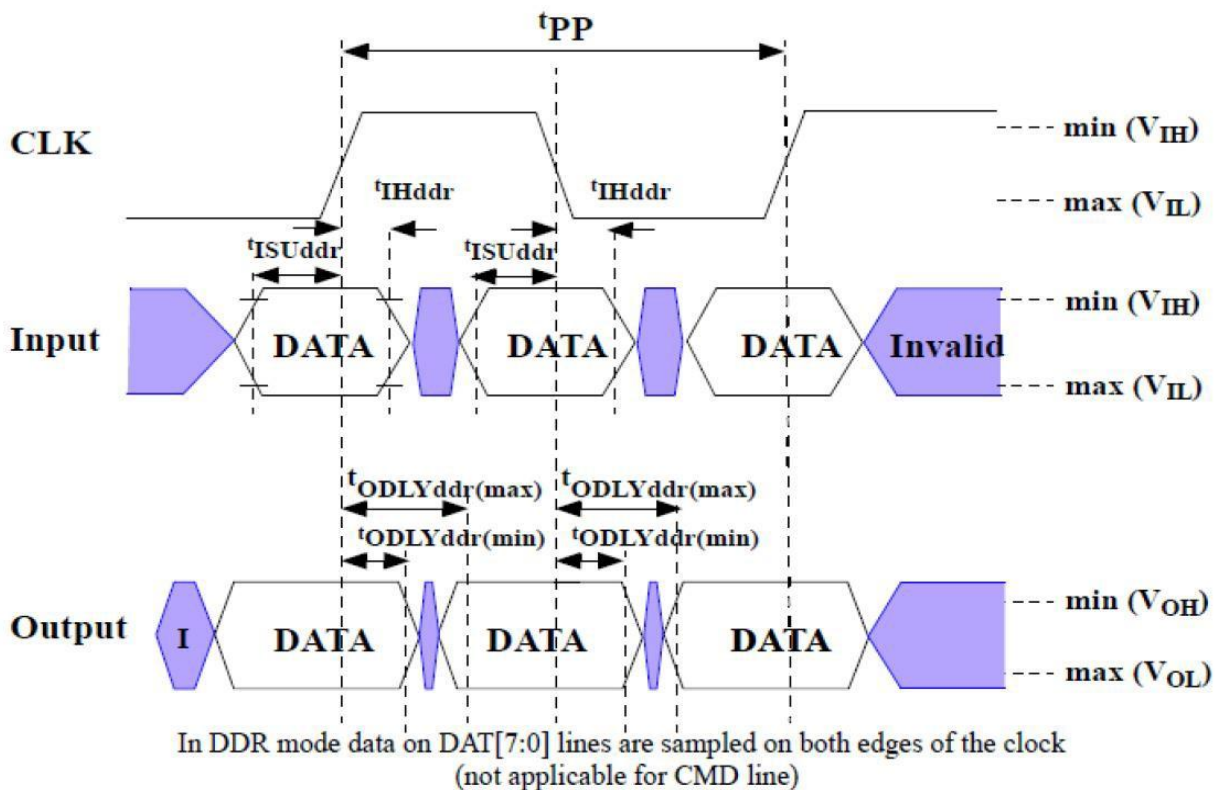
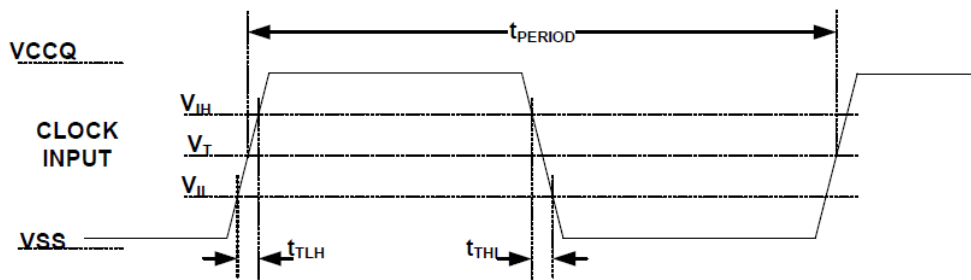

Table 5-4 Dual Data Rate Interface Timing

Parameter	Symbol	Min	Max	Unit	Remark
Input CLK¹					
Clock Duty Cycle	-	45	55	%	Include jitter, phase noise
Input/Output DAT (Referenced to CLK-DDR Mode)					
Input set-up time	t_{ISUddr}	2.5	-	ns	CL ≤20 pF
Input hold time	t_{IHddr}	2.5	-	ns	CL ≤20 pF
Output delay time	$t_{ODLYddr}$	1.5	7	ns	CL ≤20 pF
Signal rise time (DAT0-7) ²	t_{RISE}	-	2	ns	CL ≤20 pF
Signal fall time (DAT0-7)	t_{FALL}	-	2	ns	CL ≤20 pF
Note ¹ : CLK timing is measured at 50% of VDD.					
Note ² : Inputs DAT rise and fall times are measured by min (VIH) and max (VIL), and outputs DAT rise and fall times are measured by min (VOH) and max (VOL).					

Figure 5-4 HS200 Clock Signal Timing



Notes:

1. VIH denote VIH(min.) and VIL denotes VIL(max.).
2. VT=0.975V – Clock Threshold, indicates clock reference point for timing measurements.

Table 5-5 HS200 Clock Signal Timing

Symbol	Min	Max	Unit	Remark
t_{PERIOD}	5	-	ns	200MHz (Max.), between rising edges
t_{TLH}, t_{THL}	-	0.2* t_{PERIOD}	ns	$t_{TLH}, t_{THL} < 1ns$ (max.) at 200MHz, $C_{DEVICE}=6pF$, The absolute maximum value of t_{TLH}, t_{THL} is 10ns regardless of clock frequency.
Duty Cycle	30	70	%	

Figure 5-5 HS200 Device Input Timing

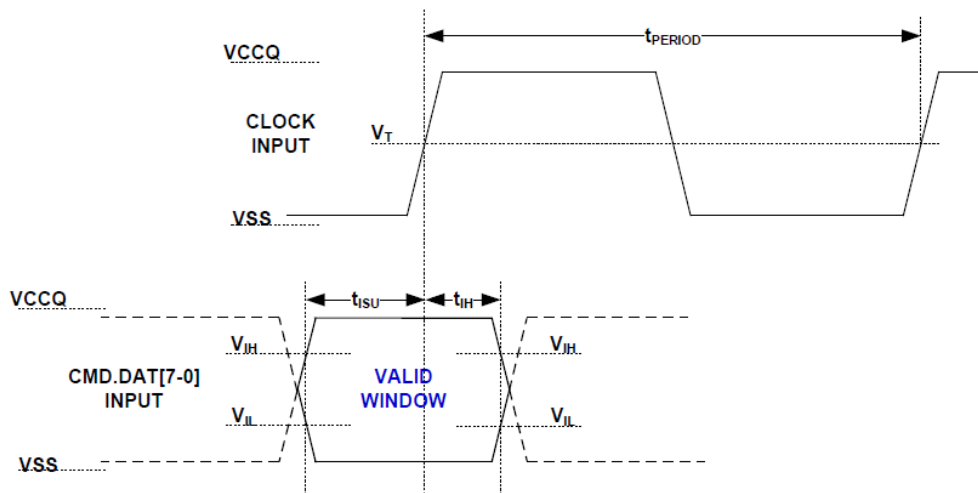

Note 1: t_{ISU} and t_{IH} are measured at V_{IL} (max) and V_{IH} (min).

Note 2: V_{IH} denote V_{IH} (min) and V_{IL} (max) denotes V_{IL} (max).

Table 5-6 HS200 Device Input Timing

Symbol	Min	Max	Unit	Remark
t _{ISU}	1.40	-	ns	C _{DEVICE} ≤ 6pF
t _{IH}	0.8	-	ns	C _{DEVICE} ≤ 6pF

Figure 5-6 HS200 Device Output Timing

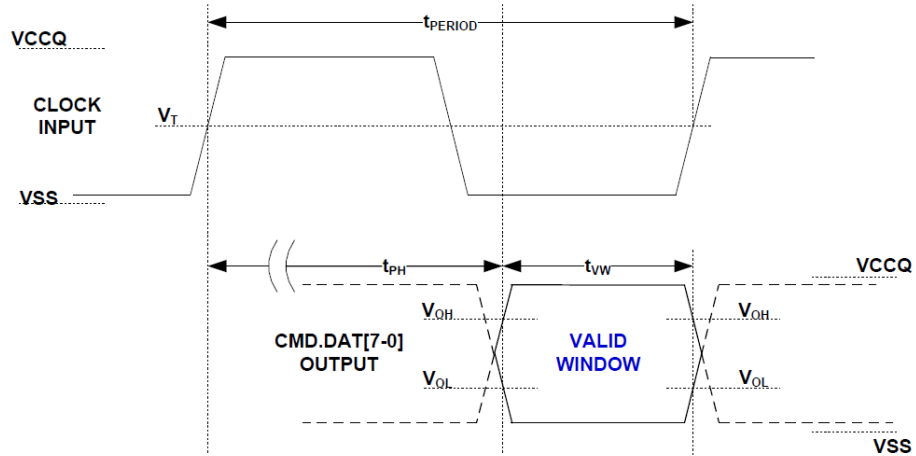

NOTE V_{OH} denotes $V_{OH(min)}$ and V_{OL} denotes $V_{OL(max)}$.

Table 5-7 HS200 Device Output Timing

Symbol	Min	Max	Unit	Remark
t_{PH}	0	2	UI	Device output momentary phase from CLK input to CMD or DAT lines output. Does not include a long term temperature drift.
Δ_{TPH}	-350 ($\Delta T = -20^\circ C$)	+1550 ($\Delta T = 90^\circ C$)	ps	Delay variation due to temperature change after tuning. Total allowable shift of output valid window (TVW) from last system Tuning procedure Δ_{TPH} is 2600ps for ΔT from $-25^\circ C$ to $125^\circ C$ during operation.
t_{vw}	0.575	-	UI	$t_{vw} = 2.88ns$ at 200MHz Using test circuit including skew among CMD and DAT lines created by the Device. Host path may add Signal Integrity induced noise, skews, etc. Expected TVW at Host input is larger than 0.475UI.

Note: Unit Interval (UI) is one bit nominal time. For example, UI=5ns at 200MHz.

Figure 5-7 Δ_{TPH} consideration

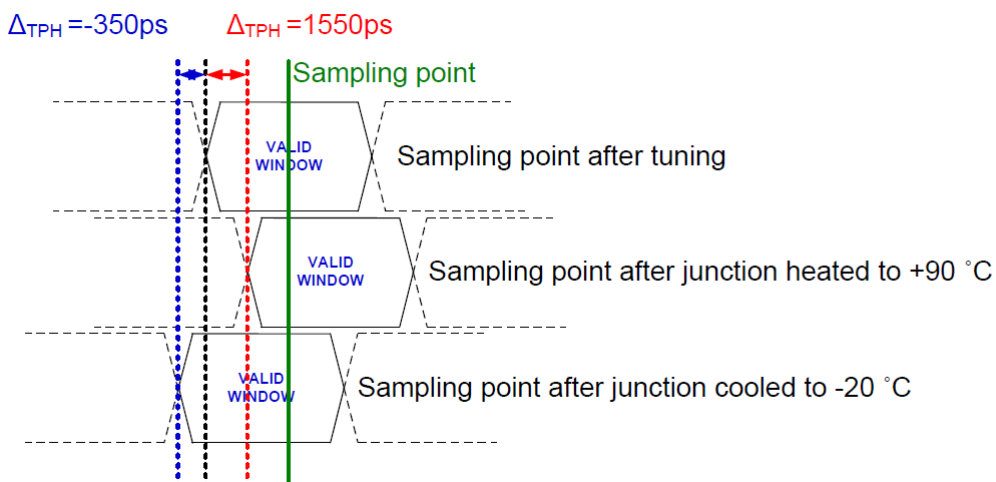

Figure 5-8 HS400 Device Input Timing

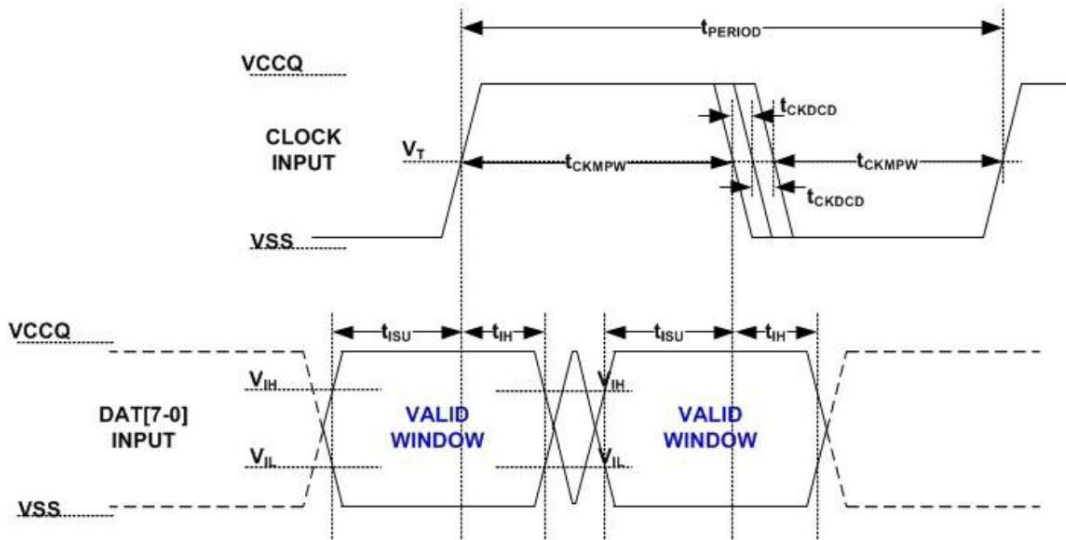

Table 5-8 HS400 Device Input Timing

Parameter	Symbol	Min	Max	Unit	Remark
Input CLK					
Cycle time data transfer mode	t_{PERIOD}	5			200MHz (Max), between rising edges with respect to V_T .
Slew rate	SR	1.125		V/ns	With respect to V_{IH}/V_{IL} .
Duty cycle distortion	t_{CKDCCD}	0	0.3	ns	Allowable deviation from an ideal 50% duty cycle. With respect to V_T . Includes jitter, phase noise.
Minimum pulse width	t_{CKMPW}	2.2		ns	With respect to V_T .
Input DAT (referenced to CLK)					
Input set-up time	t_{ISUddr}	0.4	-	ns	$C_{Device} \leq 6pF$ with respect to V_{IH}/V_{IL} .
Input hold time	t_{IHddr}	0.4	-	ns	$C_{Device} \leq 6pF$ with respect to V_{IH}/V_{IL} .
Slew rate	SR	1.125		V/ns	with respect to V_{IH}/V_{IL} .

Figure 5-9 HS400 Device Output Timing

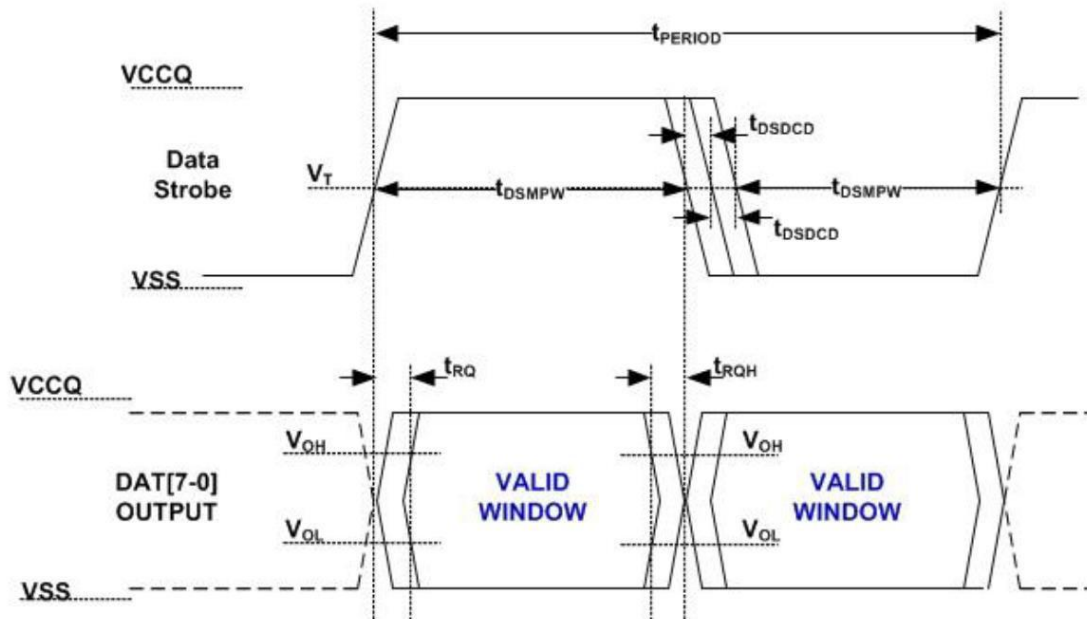

Table 5-9 HS400 Device Output Timing

Parameter	Symbol	Min	Max	Unit	Remark
Data Strobe					
Cycle time data transfer mode	t_{PERIOD}	5			200MHz(Max), between rising edges with respect to V_T .
Slew rate	SR	1.125		V/ns	With respect to V_{OH}/V_{OL} and HS400 reference load
Duty cycle distortion	t_{DSDCD}	0	0.2	ns	Allowable deviation from an input CLK duty cycle distortion (t_{CKDCD}). With respect to V_T . Includes jitter, phase noise
Minimum pulse width	t_{DSMPW}	2		ns	With respect to V_T .
Read pre-amble	t_{RPRE}	0.4		t_{PERIOD}	Max value is specified by manufacture. Value up to infinite is valid
Read post-amble	t_{RPST}	0.4		t_{PERIOD}	Max value is specified by manufacture. Value up to infinite is valid
Output DAT (Referenced to Data Strobe)					
Slew rate	SR	1.125		V/ns	With respect to V_{OH}/V_{OL} and HS400 reference load.

Table 5-10 HS400 Capacitance

Parameter	Symbol	Min	Type	Max	Unit
Pull-up resistance for CMD	R _{CMD}	4.7		50	Kohm
Pull-up resistance for DAT0-7	R _{DAT}	10		50	Kohm
Pull-down resistance for Data Strobe	R _{DS}	10		50	Kohm
Internal pull up resistance DAT1-DAT7	R _{int}	10		150	Kohm
Bus signal line capacitance	CL			13	pF
Single Device capacitance	C _{Device}			6	pF

FLEXOXON CONFIDENTIAL

6. PACKAGE



Package Size: 11.5 x 13.0 x 1.0mm

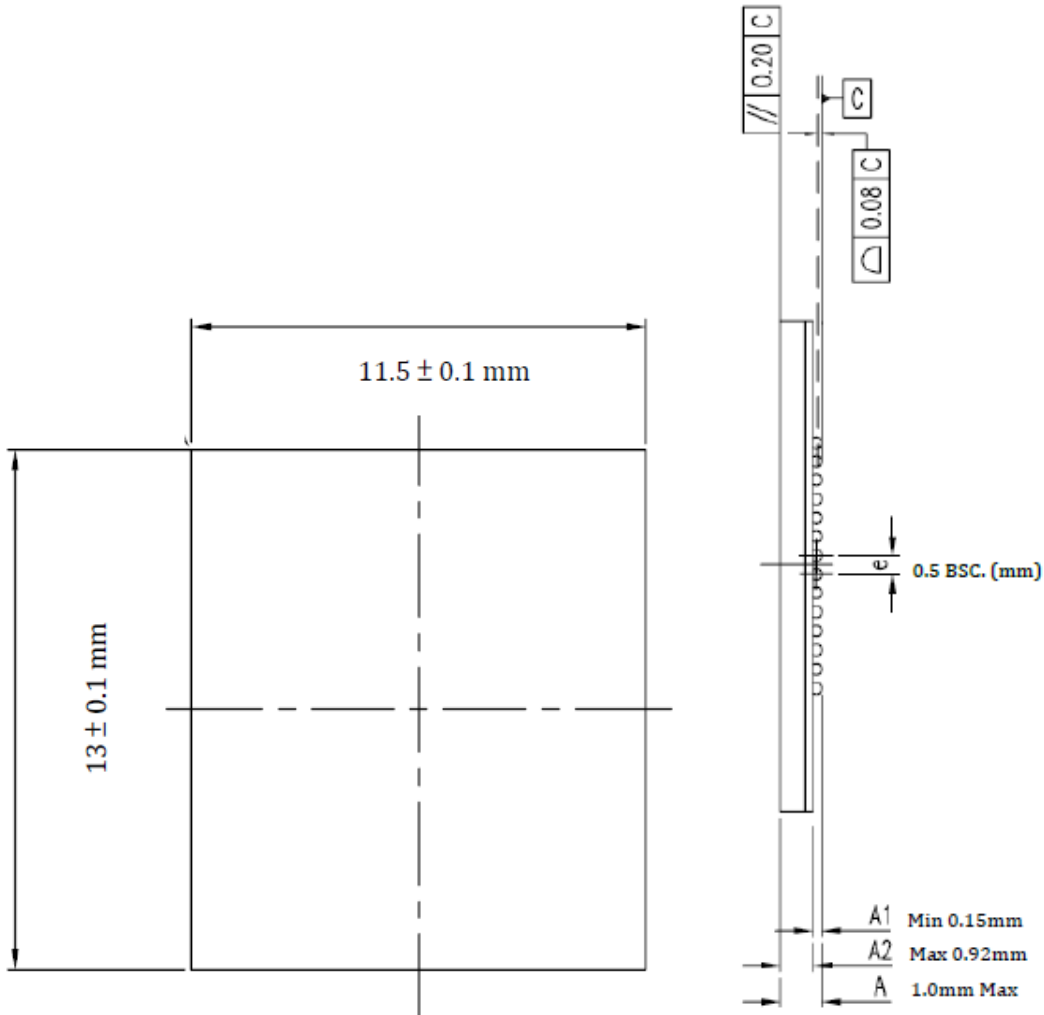

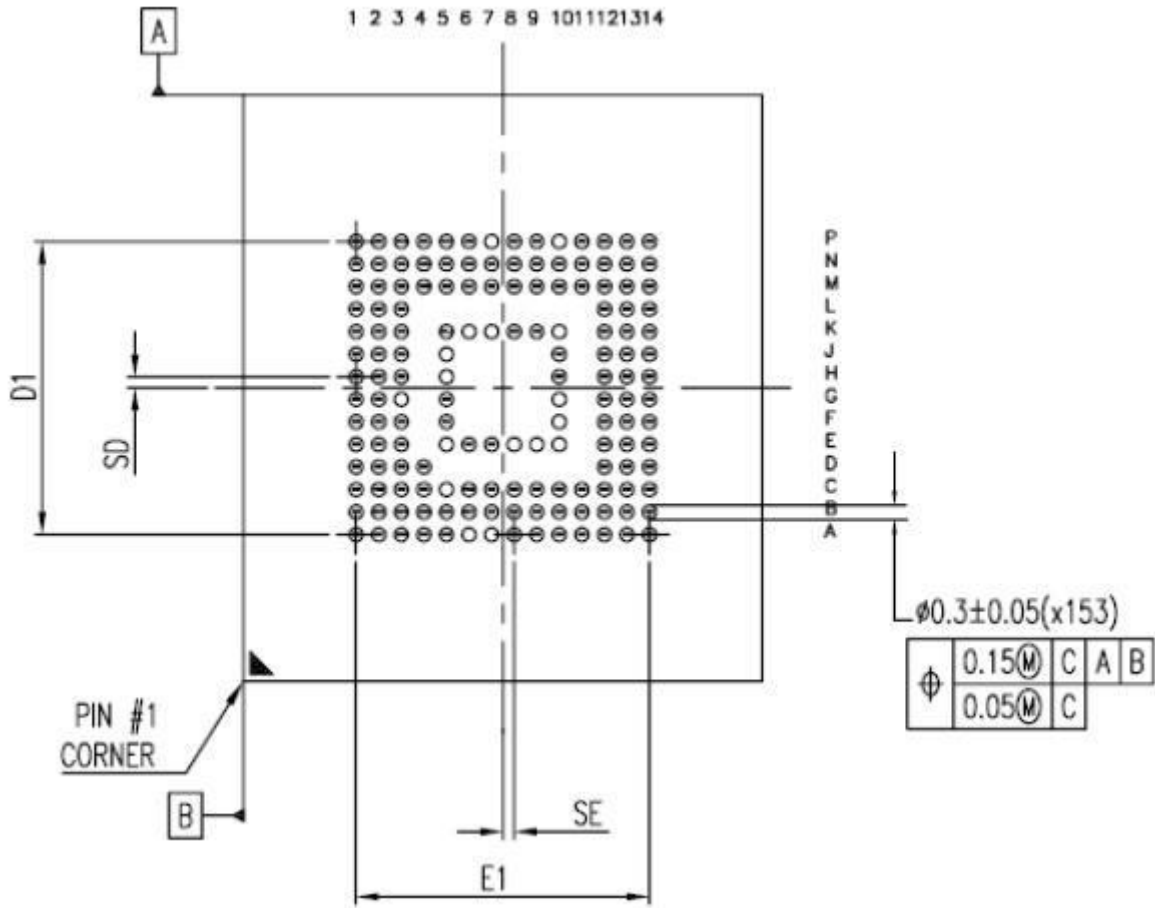

Bottom View:

N	SE (MM)	SD (MM)	E1 (MM)	D1 (MM)	JEDEC (REF)
153	0.25 BSC.	0.25 BSC.	6.50 BSC.	6.50 BSC.	MO-276 BA

7. ORDERING INFORMATION



Capacity	MPN (Automotive Grade 3)	Power System	Pin Configuration	Package Size
16GB	FEMC016GBA-T740	VCCQ: 1.8V/3.3V VCC: 3.3V	153 FBGA	11.5x13x1.0 (mm)
32GB	FEMC032GBA-T740			
64GB	FEMC064GBA-T740			
128GB	FEMC128GBA-T740			
256GB	FEMC256GBA-T740			

Capacity	MPN (Automotive Grade 2)	Power System	Pin Configuration	Package Size
16GB	FEMC016GBB-T740	VCCQ: 1.8V VCC: 3.3V	153 FBGA	11.5x13x1.0 (mm)
32GB	FEMC032GBB-T740			
64GB	FEMC064GBB-T740			
128GB	FEMC128GBB-T740			
256GB	FEMC256GBB-T740			

FLEXON CONFIDENTIAL

Revision History

Revision	Release Date	History
1.0	2022/01	First release
1.1	2024/04	Add 256GB, Product Specification

FLEXIXON CONFIDENTIAL