

## FEATURES

- Output Current up to 1.5A
- Internal Thermal Overload Protection
- Internal Short-Circuit Current Limiting
- Output Transistor Safe-Area Compensation
- Output Voltage of 5V, 6V, 8V, 9V, 12V, 15V, 18V, 20V, and 24V
- Available in SOT-223, TO-252, TO-263, TO-220 and TO-220F Packages

## DESCRIPTION

The series of fixed-Positive voltage monolithic integrated circuit voltage regulator is designed to complement LM78xx series in a wide range of applications. These applications include on-card regulation for elimination of noise and distribution problems associated with single-point regulation.

Each of these regulators can deliver up to 1.5A of output current. The internal limiting and thermal shutdown features of these regulators make them essentially immune to overload. In addition to use as fixed-voltage regulators, these devices can be used with external components to obtain adjustable output voltages and current and also as the power pass element in precision regulators.

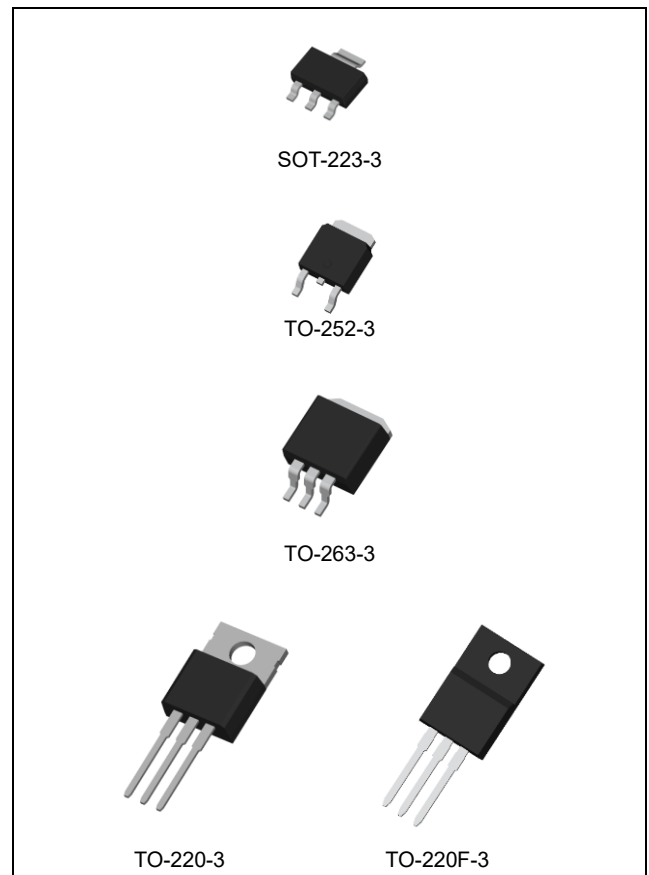

## ORDERING INFORMATION

Device	Package
LM78xxS	SOT-223-3L
LM78xxRS	TO-252-3L
LM78xxR	TO-263-3L
LM78xxT	TO-220-3L
LM78xxTP	TO-220F-3L

xx: Output Voltage

## ABSOLUTE MAXIMUM RATINGS (Note 1)

CHARACTERISTIC		SYMBOL	MIN	MAX	UNIT
Input Voltage	$V_{OUT} = 5V \text{ to } 18V$	$V_{IN}$	-	35	V
	$V_{OUT} = 20V \text{ and } 24V$		-	40	
Maximum Junction Temperature		$T_J$	-40	125	$^{\circ}C$
Storage Temperature		$T_{STG}$	-65	150	$^{\circ}C$

Note 1. Stresses beyond those listed under *Absolute Maximum Ratings* may cause permanent damage to the device. These are stress ratings only and functional operation of the device at these or any other conditions beyond those indicated under *Recommended Operating Conditions* is not implied. Exposure to absolute-maximum-rated conditions for extended periods may affect device reliability.

## ORDERING INFORMATION

VOUT	Package	Order No.	Description	Supplied As	Status
5.0V	SOT-223-3L	LM7805S	1.5A, Fixed	Tape & Reel	Active
	TO-252-3L	LM7805RS	1.5A, Fixed	Tape & Reel	Active
	TO-263-3L	LM7805R	1.5A, Fixed	Tape & Reel	Active
	TO-220-3L	LM7805T	1.5A, Fixed	Tube	Active
	TO-220F-3L	LM7805TP	1.5A, Fixed	Tube	Active
6.0V	TO-252-3L	LM7806RS	1.5A, Fixed	Tape & Reel	Contact us
	TO-263-3L	LM7806R	1.5A, Fixed	Tape & Reel	Contact us
	TO-220-3L	LM7806T	1.5A, Fixed	Tube	Active
	TO-220F-3L	LM7806TP	1.5A, Fixed	Tube	Contact us
8.0V	TO-252-3L	LM7808RS	1.5A, Fixed	Tape & Reel	Contact us
	TO-263-3L	LM7808R	1.5A, Fixed	Tape & Reel	Contact us
	TO-220-3L	LM7808T	1.5A, Fixed	Tube	Active
	TO-220F-3L	LM7808TP	1.5A, Fixed	Tube	Active
9.0V	TO-252-3L	LM7809RS	1.5A, Fixed	Tape & Reel	Contact us
	TO-263-3L	LM7809R	1.5A, Fixed	Tape & Reel	Contact us
	TO-220-3L	LM7809T	1.5A, Fixed	Tube	Active
	TO-220F-3L	LM7809TP	1.5A, Fixed	Tube	Contact us
12V	TO-252-3L	LM7812RS	1.5A, Fixed	Tape & Reel	Contact us
	TO-263-3L	LM7812R	1.5A, Fixed	Tape & Reel	Contact us
	TO-220-3L	LM7812T	1.5A, Fixed	Tube	Active
	TO-220F-3L	LM7812TP	1.5A, Fixed	Tube	Active
15V	TO-252-3L	LM7815RS	1.5A, Fixed	Tape & Reel	Contact us
	TO-263-3L	LM7815R	1.5A, Fixed	Tape & Reel	Contact us
	TO-220-3L	LM7815T	1.5A, Fixed	Tube	Active
	TO-220F-3L	LM7815TP	1.5A, Fixed	Tube	Contact us
18V	TO-252-3L	LM7818RS	1.5A, Fixed	Tape & Reel	Contact us
	TO-263-3L	LM7818R	1.5A, Fixed	Tape & Reel	Contact us
	TO-220-3L	LM7818T	1.5A, Fixed	Tube	Contact us
	TO-220F-3L	LM7818TP	1.5A, Fixed	Tube	Contact us
20V	TO-252-3L	LM7820RS	1.5A, Fixed	Tape & Reel	Contact us
	TO-263-3L	LM7820R	1.5A, Fixed	Tape & Reel	Contact us
	TO-220-3L	LM7820T	1.5A, Fixed	Tube	Contact us
	TO-220F-3L	LM7820TP	1.5A, Fixed	Tube	Contact us
24V	TO-252-3L	LM7824RS	1.5A, Fixed	Tape & Reel	Contact us
	TO-263-3L	LM7824R	1.5A, Fixed	Tape & Reel	Contact us
	TO-220-3L	LM7824T	1.5A, Fixed	Tube	Active
	TO-220F-3L	LM7824TP	1.5A, Fixed	Tube	Contact us

## PIN CONFIGURATION

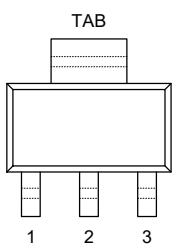
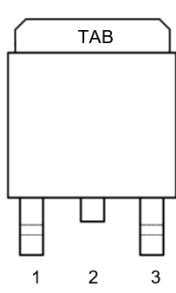
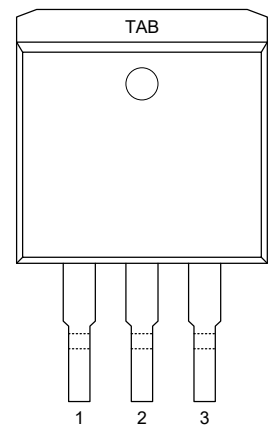
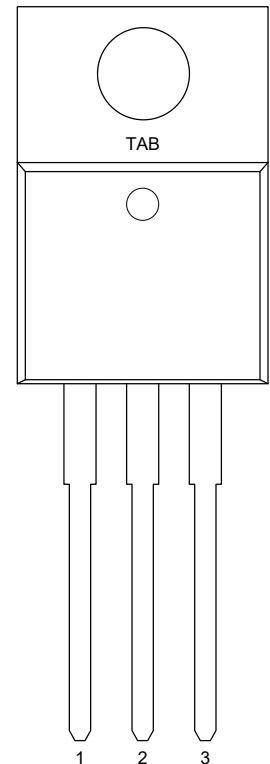
			
SOT-223	TO-252	TO-263	TO-220 / TO-220F

## PIN DESCRIPTION

Pin No.				Pin Name	Pin Function
TO-252	TO-263	TO-220	TO-220F		
1	1	1	1	INPUT	Input Voltage
2	2	2	2	GND	Ground (Common)
3	3	3	3	OUTPUT	Output Voltage
TAB	TAB	TAB	TAB	TAB	Connect to GND. Attached to heatsink for thermal relief for TO-220 package or put a copper plane connected to this pin as a thermal relief for TO-263 package.  No Connection, Electrically Isolated for TO-220F Package

## TYPICAL APPLICATION CIRCUITS

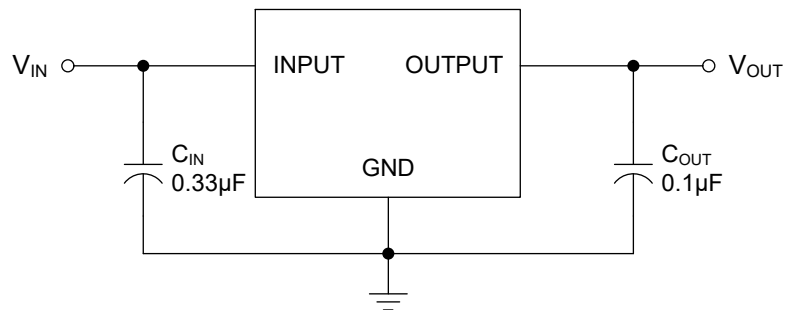

- \*  $C_{IN}$  required for stability. Value given may be increased.
- \*\*  $C_{OUT}$  may be used to improve the transient response of the regulator. It should be located as close as possible for the regulator. Value given may be increased.

## ELECTRICAL CHARACTERISTICS: LM7805

Specifications with standard type face are for  $T_J = 25^\circ\text{C}$ , and those with **boldface type** apply over  $T_J = 0^\circ\text{C}$  to  $125^\circ\text{C}$ . Conditions are  $V_{IN} = 10\text{V}$ ,  $I_{OUT} = 500\text{mA}$ ,  $C_{IN} = 0.33\mu\text{F}$ ,  $C_{OUT} = 0.1\mu\text{F}$ , unless otherwise noted.

PARAMETER	SYMBOL	TEST CONDITIONS (Note 3)	MIN	TYP	MAX	UNIT
Output Voltage (Note 4)	$V_{OUT}$		4.80	5.0	5.20	V
		$7\text{V} \leq V_{IN} \leq 20\text{V}$ , $5.0\text{mA} \leq I_{OUT} \leq 1.0\text{A}$	<b>4.75</b>	<b>5.0</b>	<b>5.25</b>	
Line Regulation	$\Delta V_{LINE}$	$7\text{V} \leq V_{IN} \leq 25\text{V}$	-	-	100	mV
		$8.0\text{V} \leq V_{IN} \leq 12\text{V}$	-	-	50	
Load Regulation	$\Delta V_{LOAD}$	$5.0\text{mA} \leq I_{OUT} \leq 1.5\text{A}$	-	-	100	mV
		$0.25\text{A} \leq I_{OUT} \leq 0.75\text{A}$	-	-	50	
Dropout Voltage	$V_D$	$I_{OUT} = 1.0\text{A}$	-	2.0	-	V
Bias Current	$I_B$		-	-	8.0	mA
Bias Current Change	$\Delta I_B$	$7\text{V} \leq V_{IN} \leq 25\text{V}$	-	-	1.3	mA
		$5.0\text{mA} \leq I_{OUT} \leq 1.0\text{A}$	-	-	0.5	

Note 3. Pulse testing techniques are used to maintain the junction temperature as close to the ambient temperature as possible. Thermal effects must be taken into account separately.

Note 4. This specification applies only for DC power dissipation permitted by the *Absolute Maximum Ratings*.

## ELECTRICAL CHARACTERISTICS: LM7806

Specifications with standard type face are for  $T_J = 25^\circ\text{C}$ , and those with **boldface type** apply over  $T_J = 0^\circ\text{C}$  to  $125^\circ\text{C}$ . Conditions are  $V_{IN} = 11\text{V}$ ,  $I_{OUT} = 500\text{mA}$ ,  $C_{IN} = 0.33\mu\text{F}$ ,  $C_{OUT} = 0.1\mu\text{F}$ , unless otherwise noted.

PARAMETER	SYMBOL	TEST CONDITIONS (Note 3)	MIN	TYP	MAX	UNIT
Output Voltage (Note 4)	$V_{OUT}$		5.76	6.0	6.24	V
		$8\text{V} \leq V_{IN} \leq 21\text{V}$ , $5.0\text{mA} \leq I_{OUT} \leq 1.0\text{A}$	<b>5.70</b>	<b>6.0</b>	<b>6.30</b>	
Line Regulation	$\Delta V_{LINE}$	$8\text{V} \leq V_{IN} \leq 25\text{V}$	-	-	120	mV
		$9\text{V} \leq V_{IN} \leq 13\text{V}$	-	-	60	
Load Regulation	$\Delta V_{LOAD}$	$5.0\text{mA} \leq I_{OUT} \leq 1.5\text{A}$	-	-	120	mV
		$0.25\text{A} \leq I_{OUT} \leq 0.75\text{A}$	-	-	60	
Dropout Voltage	$V_D$	$I_{OUT} = 1.0\text{A}$	-	2.0	-	V
Bias Current	$I_B$		-	-	8.0	mA
Bias Current Change	$\Delta I_B$	$8.0\text{V} \leq V_{IN} \leq 25\text{V}$	-	-	1.3	mA
		$5.0\text{mA} \leq I_{OUT} \leq 1.0\text{A}$	-	-	0.5	

Note 3. Pulse testing techniques are used to maintain the junction temperature as close to the ambient temperature as possible. Thermal effects must be taken into account separately.

Note 4. This specification applies only for DC power dissipation permitted by the *Absolute Maximum Ratings*.

## ELECTRICAL CHARACTERISTICS: LM7808

Specifications with standard type face are for  $T_J = 25^\circ\text{C}$ , and those with **boldface type** apply over  $T_J = 0^\circ\text{C}$  to  $125^\circ\text{C}$ . Conditions are  $V_{IN} = 14\text{V}$ ,  $I_{OUT} = 500\text{mA}$ ,  $C_{IN} = 0.33\mu\text{F}$ ,  $C_{OUT} = 0.1\mu\text{F}$ , unless otherwise noted.

PARAMETER	SYMBOL	TEST CONDITIONS (Note 3)	MIN	TYP	MAX	UNIT
Output Voltage (Note 4)	$V_{OUT}$		7.7	8.0	8.3	V
		$10.5\text{V} \leq V_{IN} \leq 23\text{V}$ , $5.0\text{mA} \leq I_{OUT} \leq 1.0\text{A}$	<b>7.6</b>	<b>8.0</b>	<b>8.4</b>	
Line Regulation	$\Delta V_{LINE}$	$10.5\text{V} \leq V_{IN} \leq 25\text{V}$	-	-	160	mV
		$11\text{V} \leq V_{IN} \leq 17\text{V}$	-	-	80	
Load Regulation	$\Delta V_{LOAD}$	$5.0\text{mA} \leq I_{OUT} \leq 1.5\text{A}$	-	-	160	mV
		$0.25\text{A} \leq I_{OUT} \leq 0.75\text{A}$	-	-	80	
Dropout Voltage	$V_D$	$I_{OUT} = 1.0\text{A}$	-	2.0	-	V
Bias Current	$I_B$		-	-	8.0	mA
Bias Current Change	$\Delta I_B$	$10.5\text{V} \leq V_{IN} \leq 25\text{V}$	-	-	1.3	mA
		$5.0\text{mA} \leq I_{OUT} \leq 1.0\text{A}$	-	-	0.5	

Note 3. Pulse testing techniques are used to maintain the junction temperature as close to the ambient temperature as possible. Thermal effects must be taken into account separately.

Note 4. This specification applies only for DC power dissipation permitted by the *Absolute Maximum Ratings*.

## ELECTRICAL CHARACTERISTICS: LM7809

Specifications with standard type face are for  $T_J = 25^\circ\text{C}$ , and those with **boldface type** apply over  $T_J = 0^\circ\text{C}$  to  $125^\circ\text{C}$ . Conditions are  $V_{IN} = 15\text{V}$ ,  $I_{OUT} = 500\text{mA}$ ,  $C_{IN} = 0.33\mu\text{F}$ ,  $C_{OUT} = 0.1\mu\text{F}$ , unless otherwise noted.

PARAMETER	SYMBOL	TEST CONDITIONS (Note 3)	MIN	TYP	MAX	UNIT
Output Voltage (Note 4)	$V_{OUT}$		8.64	9.0	9.36	V
		$11.5\text{V} \leq V_{IN} \leq 24\text{V}$ , $5.0\text{mA} \leq I_{OUT} \leq 1.0\text{A}$	<b>8.55</b>	<b>9.0</b>	<b>9.45</b>	
Line Regulation	$\Delta V_{LINE}$	$11.5\text{V} \leq V_{IN} \leq 26\text{V}$	-	-	180	mV
		$11.5\text{V} \leq V_{IN} \leq 17\text{V}$	-	-	90	
Load Regulation	$\Delta V_{LOAD}$	$5.0\text{mA} \leq I_{OUT} \leq 1.5\text{A}$	-	-	180	mV
		$0.25\text{A} \leq I_{OUT} \leq 0.75\text{A}$	-	-	90	
Dropout Voltage	$V_D$	$I_{OUT} = 1.0\text{A}$	-	2.0	-	V
Bias Current	$I_B$		-	-	8.0	mA
Bias Current Change	$\Delta I_B$	$11.5\text{V} \leq V_{IN} \leq 26\text{V}$	-	-	1.3	mA
		$5.0\text{mA} \leq I_{OUT} \leq 1.0\text{A}$	-	-	0.5	

Note 3. Pulse testing techniques are used to maintain the junction temperature as close to the ambient temperature as possible. Thermal effects must be taken into account separately.

Note 4. This specification applies only for DC power dissipation permitted by the *Absolute Maximum Ratings*.

## ELECTRICAL CHARACTERISTICS: LM7812

Specifications with standard type face are for  $T_J = 25^\circ\text{C}$ , and those with **boldface type** apply over  $T_J = 0^\circ\text{C}$  to  $125^\circ\text{C}$ . Conditions are  $V_{IN} = 19\text{V}$ ,  $I_{OUT} = 500\text{mA}$ ,  $C_{IN} = 0.33\mu\text{F}$ ,  $C_{OUT} = 0.1\mu\text{F}$ , unless otherwise noted.

PARAMETER	SYMBOL	TEST CONDITIONS (Note 3)	MIN	TYP	MAX	UNIT
Output Voltage (Note 4)	$V_{OUT}$		11.5	12	12.5	V
		$14.5\text{V} \leq V_{IN} \leq 27\text{V}$ , $5.0\text{mA} \leq I_{OUT} \leq 1.0\text{A}$	<b>11.4</b>	<b>12</b>	<b>12.6</b>	
Line Regulation	$\Delta V_{LINE}$	$14.5\text{V} \leq V_{IN} \leq 30\text{V}$	-	-	240	mV
		$16\text{V} \leq V_{IN} \leq 22\text{V}$	-	-	120	
Load Regulation	$\Delta V_{LOAD}$	$5.0\text{mA} \leq I_{OUT} \leq 1.5\text{A}$	-	-	240	mV
		$0.25\text{A} \leq I_{OUT} \leq 0.75\text{A}$	-	-	120	
Dropout Voltage	$V_D$	$I_{OUT} = 1.0\text{A}$	-	2.0	-	V
Bias Current	$I_B$		-	-	8.0	mA
Bias Current Change	$\Delta I_B$	$14.5\text{V} \leq V_{IN} \leq 30\text{V}$	-	-	1.3	mA
		$5.0\text{mA} \leq I_{OUT} \leq 1.0\text{A}$	-	-	0.5	

Note 3. Pulse testing techniques are used to maintain the junction temperature as close to the ambient temperature as possible. Thermal effects must be taken into account separately.

Note 4. This specification applies only for DC power dissipation permitted by the *Absolute Maximum Ratings*.

## ELECTRICAL CHARACTERISTICS: LM7815

Specifications with standard type face are for  $T_J = 25^\circ\text{C}$ , and those with **boldface type** apply over  $T_J = 0^\circ\text{C}$  to  $125^\circ\text{C}$ . Conditions are  $V_{IN} = 23\text{V}$ ,  $I_{OUT} = 500\text{mA}$ ,  $C_{IN} = 0.33\mu\text{F}$ ,  $C_{OUT} = 0.1\mu\text{F}$ , unless otherwise noted.

PARAMETER	SYMBOL	TEST CONDITIONS (Note 3)	MIN	TYP	MAX	UNIT
Output Voltage (Note 4)	$V_{OUT}$		14.4	15	15.6	V
		$17.5\text{V} \leq V_{IN} \leq 30\text{V}$ , $5.0\text{mA} \leq I_{OUT} \leq 1.0\text{A}$	<b>14.25</b>	<b>15</b>	<b>15.75</b>	
Line Regulation	$\Delta V_{LINE}$	$17.5\text{V} \leq V_{IN} \leq 30\text{V}$	-	-	300	mV
		$20\text{V} \leq V_{IN} \leq 26\text{V}$	-	-	150	
Load Regulation	$\Delta V_{LOAD}$	$5.0\text{mA} \leq I_{OUT} \leq 1.5\text{A}$	-	-	300	mV
		$0.25\text{A} \leq I_{OUT} \leq 0.75\text{A}$	-	-	150	
Dropout Voltage	$V_D$	$I_{OUT} = 1.0\text{A}$	-	2.0	-	V
Bias Current	$I_B$		-	-	8.0	mA
Bias Current Change	$\Delta I_B$	$17.5\text{V} \leq V_{IN} \leq 30\text{V}$	-	-	1.3	mA
		$5.0\text{mA} \leq I_{OUT} \leq 1.0\text{A}$	-	-	0.5	

Note 3. Pulse testing techniques are used to maintain the junction temperature as close to the ambient temperature as possible. Thermal effects must be taken into account separately.

Note 4. This specification applies only for DC power dissipation permitted by the *Absolute Maximum Ratings*.

## ELECTRICAL CHARACTERISTICS: LM7824

Specifications with standard type face are for  $T_J = 25^\circ\text{C}$ , and those with **boldface type** apply over  $T_J = 0^\circ\text{C}$  to  $125^\circ\text{C}$ . Conditions are  $V_{IN} = 33\text{V}$ ,  $I_{OUT} = 500\text{mA}$ ,  $C_{IN} = 0.33\mu\text{F}$ ,  $C_{OUT} = 0.1\mu\text{F}$ , unless otherwise noted.

PARAMETER	SYMBOL	TEST CONDITIONS (Note 3)	MIN	TYP	MAX	UNIT
Output Voltage (Note 4)	$V_{OUT}$		23	24	25	V
		$27\text{V} \leq V_{IN} \leq 38\text{V}$ , $5.0\text{mA} \leq I_{OUT} \leq 1.0\text{A}$	<b>22.8</b>	<b>24</b>	<b>25.2</b>	
Line Regulation	$\Delta V_{LINE}$	$27\text{V} \leq V_{IN} \leq 38\text{V}$	-	-	480	mV
		$30\text{V} \leq V_{IN} \leq 36\text{V}$	-	-	240	
Load Regulation	$\Delta V_{LOAD}$	$5.0\text{mA} \leq I_{OUT} \leq 1.5\text{A}$	-	-	480	mV
		$0.25\text{A} \leq I_{OUT} \leq 0.75\text{A}$	-	-	240	
Dropout Voltage	$V_D$	$I_{OUT} = 1.0\text{A}$	-	2.0	-	V
Bias Current	$I_B$		-	-	8.0	mA
Bias Current Change	$\Delta I_B$	$27\text{V} \leq V_{IN} \leq 38\text{V}$	-	-	1.3	mA
		$5.0\text{mA} \leq I_{OUT} \leq 1.0\text{A}$	-	-	0.5	

Note 3. Pulse testing techniques are used to maintain the junction temperature as close to the ambient temperature as possible. Thermal effects must be taken into account separately.

Note 4. This specification applies only for DC power dissipation permitted by the *Absolute Maximum Ratings*.

## Maximum Output Current Capability

The LM78xx can deliver a continuous current of 3.0A over the full operating junction temperature range. However, the output current is limited by the restriction of power dissipation which differs from packages. A heat sink may be required depending on the maximum power dissipation and maximum ambient temperature of application. With respect to the applied package, the maximum output current of 3.0A may be still undeliverable due to the restriction of the power dissipation of LM78xx. Under all possible conditions, the junction temperature must be within the range specified under operating conditions. The temperatures over the device are given by:

$$T_C = T_A + P_D \times \theta_{CA} \quad / \quad T_J = T_C + P_D \times \theta_{JC} \quad / \quad T_J = T_A + P_D \times \theta_{JA}$$

where  $T_J$  is the junction temperature,  $T_C$  is the case temperature,  $T_A$  is the ambient temperature,  $P_D$  is the total power dissipation of the device,  $\theta_{CA}$  is the thermal resistance of case-to-ambient,  $\theta_{JC}$  is the thermal resistance of junction-to-case, and  $\theta_{JA}$  is the thermal resistance of junction to ambient.

The total power dissipation of the device is given by:

$$\begin{aligned} P_D &= P_{IN} - P_{OUT} = (V_{IN} \times I_{IN}) - (V_{OUT} \times I_{OUT}) \\ &= (V_{IN} \times (I_{OUT} + I_{GND})) - (V_{OUT} \times I_{OUT}) = (V_{IN} - V_{OUT}) \times I_{OUT} + V_{IN} \times I_{GND} \end{aligned}$$

where  $I_{GND}$  is the operating ground current of the device which is specified at the Electrical Characteristics. The maximum allowable temperature rise ( $T_{Rmax}$ ) depends on the maximum ambient temperature ( $T_{Amax}$ ) of the application, and the maximum allowable junction temperature ( $T_{Jmax}$ ):

$$T_{Rmax} = T_{Jmax} - T_{Amax}$$

The maximum allowable value for junction-to-ambient thermal resistance,  $\theta_{JA}$ , can be calculated using the formula:

$$\theta_{JA} = T_{Rmax} / P_D = (T_{Jmax} - T_{Amax}) / P_D$$

LM78xx is available in SOT223, TO252, TO263 and TO220/TO220F packages. The thermal resistance depends on amount of copper area or heat sink, and on air flow. If the maximum allowable value of  $\theta_{JA}$  calculated above is over 137°C/W for SOT223 package, over 105 °C/W for TO252 package, over 80 °C/W for TO263 package, over 70 °C/W for TO220 package, over 72 °C/W for TO220F package, no heat sink is needed since the package can dissipate enough heat to satisfy these requirements. If the value for allowable  $\theta_{JA}$  falls near or below these limits, a heat sink or proper area of copper plane is required.

In summary, the absolute maximum ratings of thermal resistances are as follow:

### Absolute Maximum Ratings of Thermal Resistance

No heat sink / No air flow / No adjacent heat source /  $T_A = 25^\circ\text{C}$

Characteristic	Symbol	Rating	Unit
Thermal Resistance Junction-To-Ambient / TO223	$\theta_{JA-SOT223}$	137	°C/W
Thermal Resistance Junction-To-Ambient / TO252	$\theta_{JA-TO252}$	105	°C/W
Thermal Resistance Junction-To-Ambient / TO263	$\theta_{JA-TO263}$	80	°C/W
Thermal Resistance Junction-To-Ambient / TO220	$\theta_{JA-TO220}$	70	°C/W
Thermal Resistance Junction-To-Ambient / TO220F	$\theta_{JA-TO220F}$	72	°C/W

Characteristic	Symbol	Rating	Unit
Thermal Resistance Junction-To-Case / TO223	$\theta_{JC-SOT223}$	18	°C/W
Thermal Resistance Junction-To-Case / TO252	$\theta_{JC-TO252}$	12	°C/W
Thermal Resistance Junction-To-Case / TO263	$\theta_{JC-TO263}$	5	°C/W
Thermal Resistance Junction-To-Case / TO220	$\theta_{JC-TO220}$	5	°C/W
Thermal Resistance Junction-To-Case / TO220F	$\theta_{JC-TO220F}$	7	°C/W

In case that there is no cooling solution and no heat sink / copper plane area for heat sink, the maximum allowable power dissipation of each package is as follow;

Characteristic	Symbol	Rating	Unit
Maximum Allowable Power Dissipation at $T_A=25^\circ\text{C}$ / SOT223	$P_{DMax-SOT223}$	0.729	W
Maximum Allowable Power Dissipation at $T_A=25^\circ\text{C}$ / TO252	$P_{DMax-TO252}$	0.952	W
Maximum Allowable Power Dissipation at $T_A=25^\circ\text{C}$ / TO263	$P_{DMax-TO263}$	1.250	W
Maximum Allowable Power Dissipation at $T_A=25^\circ\text{C}$ / TO220	$P_{DMax-TO220}$	1.429	W
Maximum Allowable Power Dissipation at $T_A=25^\circ\text{C}$ / TO220F	$P_{DMax-TO220F}$	1.389	W

- Please note that above maximum allowable power dissipation is based on the minimum copper plane area which does not exceed the proper footprint of the package. And the ambient temperature is 25°C.

If proper cooling solution such as heat sink, copper plane area, air flow is applied, the maximum allowable power dissipation could be increased. However, if the ambient temperature is increased, the allowable power dissipation would be decreased.

## REVISION NOTICE

The description in this datasheet is subject to change without any notice to describe its electrical characteristics properly.