

Description

Dual low voltage differential signaling (LVDS), driver receiver designed, packaged and qualified for use in aerospace environments in a low-power and fast-transmission standard, and operating at 3.3 V power supply (3.6 V max operating and 4.8 V AMR). The RHFLVDSR2D2 operates over a controlled impedance of 100-ohm transmission media that may be printed circuit board traces, back planes, or cables.

The circuit features an internal fail-safe function to ensure a known state in case of an input short circuit or floating input. All pins have cold spare buffers to ensure they are in high impedance when V_{CC} is tied to GND.

The RHFLVDSR2D2 can operate over a large temperature range of $-55\text{ }^{\circ}\text{C}$ to $+125\text{ }^{\circ}\text{C}$ and it is housed in an hermetic Ceramic Flat-18 package.

Features

- Dual drivers, TTL compatible inputs/LVDS outputs
- Dual receivers, LVDS inputs/TTL compatible outputs
- Individual Enable/Disable function with high-impedance
- ANSI TIA/EIA-644 compliant
- 400 Mbps (200 MHz)
- Cold spare on all pins
- Fail-safe function
- 3.3 V operating power supply
- 4.8 V absolute rating
- Power consumption: 50 mW at 3.3 V
- Hermetic package
- Large input common mode: -4 V to $+5\text{ V}$
- Guaranteed up to 300 krad TID
- SEL immune up to $135\text{ MeV}\cdot\text{cm}^2/\text{mg}$
- SET/SEU immune up to $32\text{ MeV}\cdot\text{cm}^2/\text{mg}$
- SMD pin: 5962F06202
- Mass: 0.65 g

Contents

1	Functional description and pin configuration	3
2	Maximum ratings and operating conditions	4
3	Radiation	5
4	Electrical characteristics	6
5	Test circuit for the driver	9
6	Test circuit for the receiver	11
7	Package information	13
	7.1 Ceramic Flat-18 package information	14
8	Ordering information	15
9	Shipping information	16
10	Revision history	18

1 Functional description and pin configuration

Figure 1. Functional diagram and pinout

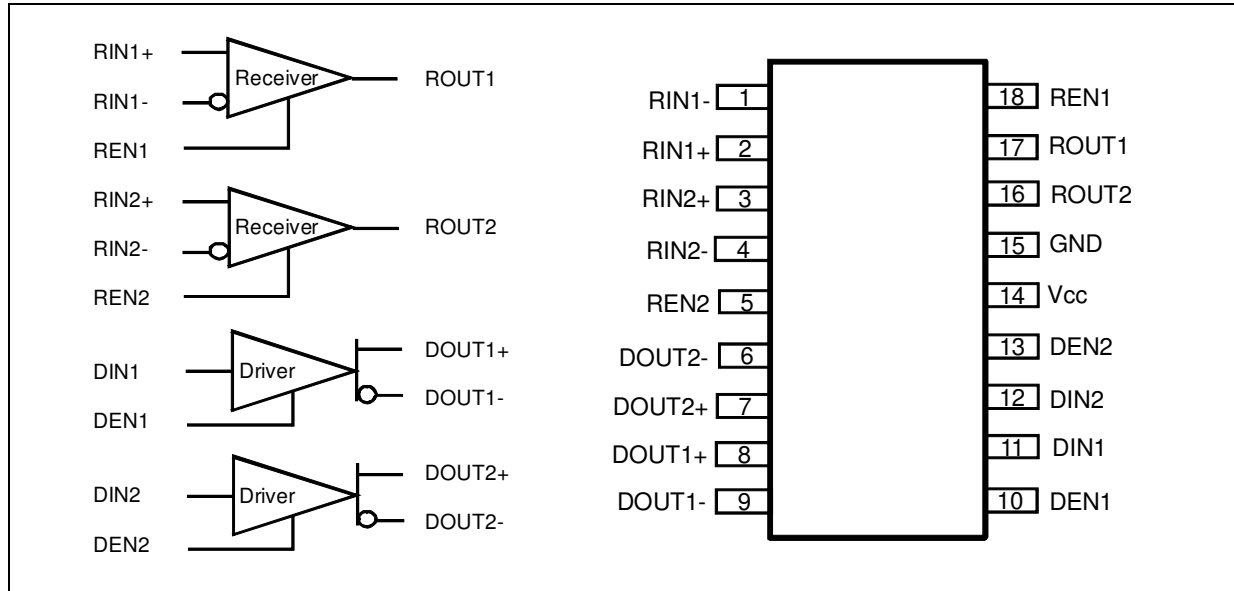

Table 1. Truth table: Driver

Enables	Input	Output	
DEN	DIN	DOUT+	DOUT-
L	X	Z	Z
H or floating (internal pull-up)	L	L	H
	H	H	L
	Open	L	H

Table 2. Truth table: Receiver

Enables	Input	Output
REN	RIN+ - RIN-	ROUT
L	X	Z
H or floating (internal pull-up)	$V_{id} \geq 0.1\text{ V}$	H
	$V_{id} \leq -0.1\text{ V}$	L
	$-0.1\text{ V} < V_{id} < +0.1\text{ V}$?
	Full fail-safe Open/Short or terminated	H

Note: $V_{id} = (V_{IN+}) - (V_{IN-})$, L = low level, H = high Level, X = don't care, Z = high impedance (off)

2 Maximum ratings and operating conditions

Absolute maximum ratings are those values beyond which damage to the device may occur. Functional operation under these conditions is not implied.

Table 3. Absolute maximum ratings

Symbol	Parameter	Value	Unit
V_{CC}	Supply voltage ⁽¹⁾	4.8	V
V_i	TTL inputs (operating or cold-spares)	-0.3 to +4.8	
V_{OUT}	LVDS outputs and TTL outputs (operating or cold-spares)	-0.3 to +4.8	
V_{IN}	LVDS inputs (operating or cold-spares)	-5 to +6	
V_{ID}	Differential amplitude on LVDS input (operating or cold-spares)	5	V_{PP}
T_{stg}	Storage temperature range	-65 to +150	°C
T_j	Maximum junction temperature	+150	
R_{thjc}	Thermal resistance junction to case ⁽²⁾	21	°C/W
ESD	HBM: Human body model		kV
	– All pins	2	
	– LVDS inputs and outputs vs. GND	8	
	CDM: Charge device model	500	V

1. All voltages, except the differential I/O bus voltage, are with respect to the network ground terminal.
2. Short-circuits can cause excessive heating. Destructive dissipation can result from short-circuits on the amplifiers.

Table 4. Operating conditions

Symbol	Parameter	Min.	Typ.	Max.	Unit
V_{CC}	Supply voltage	3	3.3	3.6	V
V_{CM}	Static common mode on the receiver	-4		+5	
V_{IN}	Driver DC input voltage (TTL inputs)	0		3.6	
T_A	Ambient temperature range	-55		+125	°C

3 Radiation

Total dose (MIL-STD-883 TM 1019)

The products guaranteed in radiation within the RHA QML-V system fully comply with the MIL-STD-883 TM 1019 specification.

The RHFLVDSR2D2 is RHA QML-V, tested and characterized in full compliance with the MIL-STD-883 specification, between 50 and 300 rad/s only (full CMOS technology).

All parameters provided in [Table 6: Electrical characteristics](#) apply to both pre- and post-irradiation, as follows:

- All test are performed in accordance with MIL-PRF-38535 and test method 1019 of MIL-STD-883 for total ionizing dose (TID).
- The initial characterization is performed in qualification only on both biased and unbiased parts.
- Each wafer lot is tested at high dose rate only, in the worst bias case condition, based on the results obtained during the initial qualification.

Heavy ions

The behavior of the product when submitted to heavy ions is not tested in production. Heavy-ion trials are performed on qualification lots only.

Table 5. Radiations

Type	Characteristics	Value	Unit
TID	High-dose rate (50 - 300 rad/sec)	300	krad
Heavy ions	SEL immunity up to: (with a particle angle of 60 °, at 125 °C)	135	MeV.cm ² /mg
	SEL immunity up to: (with a particle angle of 0 °, at 125 °C)	67	
	SET/SEU immunity up to: (at 25 °C)	32	

4 Electrical characteristics

In [Table 6](#) below, $V_{CC} = 3\text{ V to }3.6\text{ V}$, capa-load (CL) = 10 pF, typical values are at $T_{amb} = +25\text{ }^\circ\text{C}$, min. and max values are at $T_{amb} = -55\text{ }^\circ\text{C}$ and $+125\text{ }^\circ\text{C}$ unless otherwise specified.

Table 6. Electrical characteristics

Symbol	Parameter	Test conditions	Min.	Typ.	Max.	Unit	
Whole circuit							
I_{CC}	Total enabled supply current, drivers and receivers enabled, not switching	Driver: $V_{IN} = 0\text{ V or }V_{CC}$ and load = 100 W. receiver: $V_{ID} = 400\text{ mV}$		15	19	mA	
I_{CCZ}	Total disabled supply current, loaded or not loaded, drivers and receivers disabled	R_{EN} and $D_{EN} = \text{GND}$ Driver: $V_{IN} = 0\text{ V or }V_{CC}$ Receiver: $V_{ID} = 400\text{ mV}$			4		
V_{IH}	Input voltage high	R_{EN} , D_{EN} , and TTL inputs	2		V_{CC}	V	
V_{IL}	Input voltage low		GND		0.8		
I_{IH}	High level input current	R_{EN} , D_{EN} , and TTL inputs $V_{CC} = 3.6\text{ V}$, $V_{IN} = V_{CC}$	-10		10	μA	
I_{IL}	Low level input current	R_{EN} , D_{EN} and TTL inputs $V_{CC} = 3.6\text{ V}$, $V_{IN} = 0$	-10		10		
$I_{OFF}^{(1)}$	LVDS outputs power off leakage current	$V_{CC} = 0\text{ V}$, $V_{OUT} = 3.6\text{ V}$	-50		+50		
	LVDS inputs power off leakage current	$V_{CC} = 0\text{ V}$, $V_{IN} = -4\text{ V to }5\text{ V}$	-60		60		
	TTL I/Os power off leakage current	$V_{CC} = 0\text{ V}$ V_{IN} , R_{EN} , and $D_{EN} = 3.6\text{ V}$ $V_{OUT} = 3.6\text{ V}$	-10		10		
Driver							
V_{OH}	Output voltage high	$R_L = 100\ \Omega$			1.65	V	
V_{OL}	Output voltage low		0.925				
V_{OD}	Differential output voltage		250		400	mV	
DV_{OD}	Change of magnitude of V_{OD1} for complementary output states				10		
V_{OS}	Offset voltage		1.125		1.45	V	
DV_{OS}	Change of magnitude of V_{OS} for complementary output states				15	mV	
I_{OS}	Output short-circuit current		$V_{IN} = 0\text{ V and }V_{OUT-} = 0\text{ V}$ or $V_{IN} = V_{CC}$ and $V_{OUT+} = 0\text{ V}$	-9			mA
I_{OZ}	High impedance output current		Disabled, $V_{OUT} = 3.6\text{ V or GND}$	-10		10	μA
C_{IN}	Input capacitance			3		pF	

Table 6. Electrical characteristics (continued)

Symbol	Parameter	Test conditions	Min.	Typ.	Max.	Unit
t_{PHLD}	Propagation delay time, high to low output	Load: refer to Figure 3	0.5		1.5	ns
t_{PLHD}	Propagation delay time, low to high output		0.5		1.5	
t_r	Differential output signal rise time			0.8		
t_f	Differential output signal fall time			0.8		
t_{SK1}	Channel-to-channel skew ⁽²⁾				0.28	
t_{SK2}	Chip-to-chip skew ⁽³⁾⁽⁴⁾				0.7	
t_{SKD}	Differential skew ⁽⁵⁾ ($t_{PHLD}-t_{PLHD}$)			0.3		
t_{PHZ}	Propagation delay time, high level to high impedance output	Load: refer to Figure 4			2.8	
t_{PLZ}	Propagation delay time, low level to high impedance output				2.8	
t_{PZH}	Propagation delay time, high impedance to high level output				2.5	
t_{PZL}	Propagation delay time, high impedance to low level output				2.5	
Receiver						
V_{TL}	Differential input low threshold	$+0.05\text{ V} < V_{CM} < +2.35\text{ V}$			-100	mV
		$-4\text{ V} < V_{CM} < +5\text{ V}$			-130	
V_{TH}	Differential input high threshold	$+0.05\text{ V} < V_{CM} < +2.35\text{ V}$	+100			
		$-4\text{ V} < V_{CM} < +5\text{ V}$	+130			
V_{CL}	TTL input clamp voltage	$I_{CL} = 18\text{ mA}$			1.5	V
V_{CMR}	Common mode voltage range	$V_{ID} = 200\text{ mVp-p}$	-4		+5	
V_{CMREJ}	Common mode rejection ⁽⁶⁾	$F = 10\text{ MHz}$			300	mVp-p
I_{ID}	Differential Input current	$V_{ID} = 400\text{ mVp-p}$	-10		10	μA
I_{ICM}	Common mode Input current	$V_{IC} = -4\text{ V to } +5\text{ V}$	-70		70	
V_{OH}	Output voltage high	$I_{OH} = -0.4\text{ mA}, V_{CC} = 3\text{ V}$	2.7			V
V_{OL}	Output voltage low	$I_{OL} = 2\text{ mA}, V_{CC} = 3\text{ V}$			0.25	
I_{OS}	Output short circuit current	$V_{OUT} = 0\text{ V}$	-90		-30	mA
I_{OZ}	Output tri-state current	Disabled, $V_{OUT} = 0\text{ V or } V_{CC}$	-10		10	μA
C_{IN}	Input capacitance	IN+ or IN- to GND		3		pF
R_{out}	Output resistance			45		Ω

Table 6. Electrical characteristics (continued)

Symbol	Parameter	Test conditions	Min.	Typ.	Max.	Unit
t_{PHLD}	Propagation delay time, high to low output	$V_{ID} = 200$ mVp-p, input pulse from 1.1 V to 1.3 V, $V_{CM} = 1.2$ V Load: refer to Figure 6	1		2.5	ns
t_{PLHD}	Propagation delay time, low to high output		1		2.5	
t_{SK1}	Channel-to-channel skew ⁽²⁾	$V_{ID} = 200$ mVp-p Load: refer to Figure 3			0.25	ns
t_{SK2}	Chip-to-chip skew ⁽³⁾⁽⁴⁾				0.7	
t_{SKD}	Differential skew ⁽⁵⁾ ($t_{PHLD} - t_{PLHD}$)				0.3	
t_r	Output signal rise time	Load: refer to Figure 3		0.9		
t_f	Output signal fall time			0.9		
t_{PLZ}	Propagation delay time, low level to high impedance output	Load: refer to Figure 4			3.8	
t_{PHZ}	Propagation delay time, high level to high impedance output				3.8	
t_{PZH}	Propagation delay time, high impedance to high level output				3.8	
t_{PZL}	Propagation delay time, high impedance to low level output				3.8	
t_{D1}	Fail-safe to active time			1		μ s
t_{D2}	Active to fail-safe time			1		

1. All pins except pin under test and V_{CC} are floating
2. t_{SK1} is the maximum delay time difference between all outputs of the same device (measured with all inputs connected together).
3. t_{SK2} is the maximum delay time difference between outputs of all devices when they operate with the same supply voltage, at the same temperature.
4. Guaranteed by design
5. t_{SKD} is the maximum delay time difference between t_{PHLD} and t_{PLHD} , see [Figure 3](#).
6. Guaranteed by characterization on bench.

Cold sparing

The RHFLVDSR2D2 features a cold spare input and output buffer. In high reliability applications, cold sparing enables a redundant device to be tied to the data bus with its power supply at 0 V ($V_{CC} = GND$) without affecting the bus signals or injecting current from the I/Os to the power supplies. Cold sparing also allows redundant devices to be kept powered off so that they can be switched on only when required. This has no impact on the application. Cold sparing is achieved by implementing a high impedance between the I/Os and V_{CC} . ESD protection is ensured through a non-conventional dedicated structure.

Fail-safe

In many applications, inputs need a fail-safe function to avoid an uncertain output state when the inputs are not connected properly. For the drivers: in case of an LVDS input short circuit or floating inputs, the TTL outputs remain in stable logic-high state.

5 Test circuit for the driver

Figure 2. Voltage and current definition

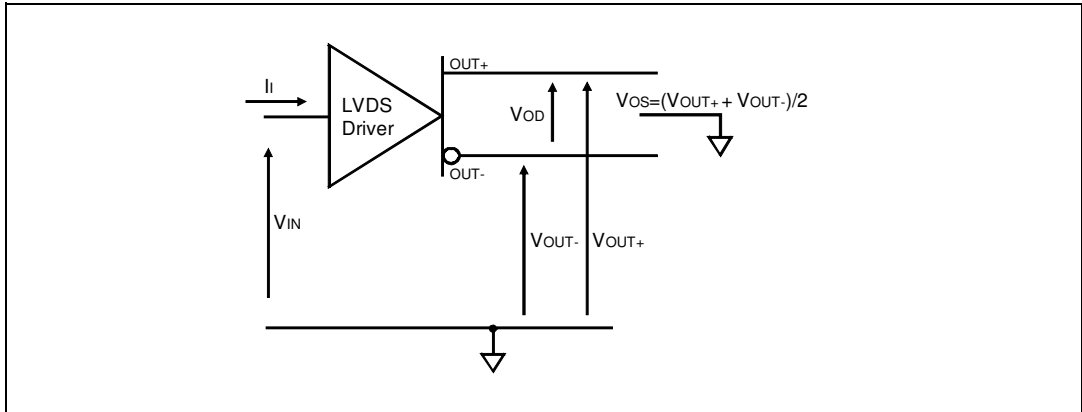
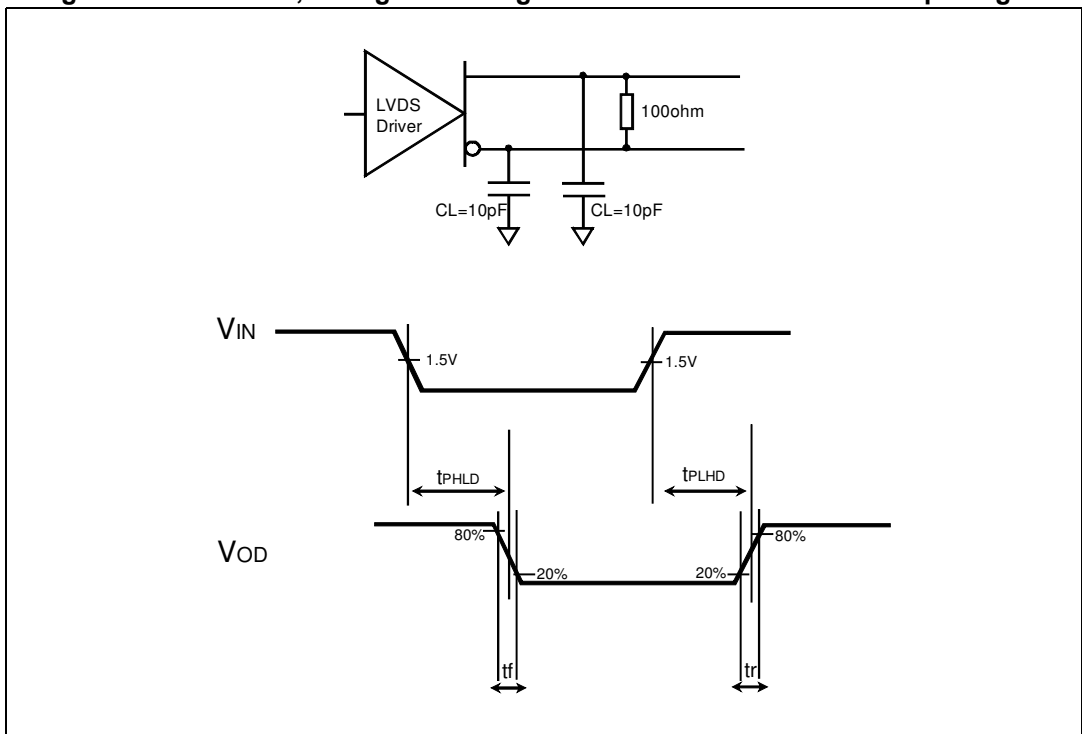
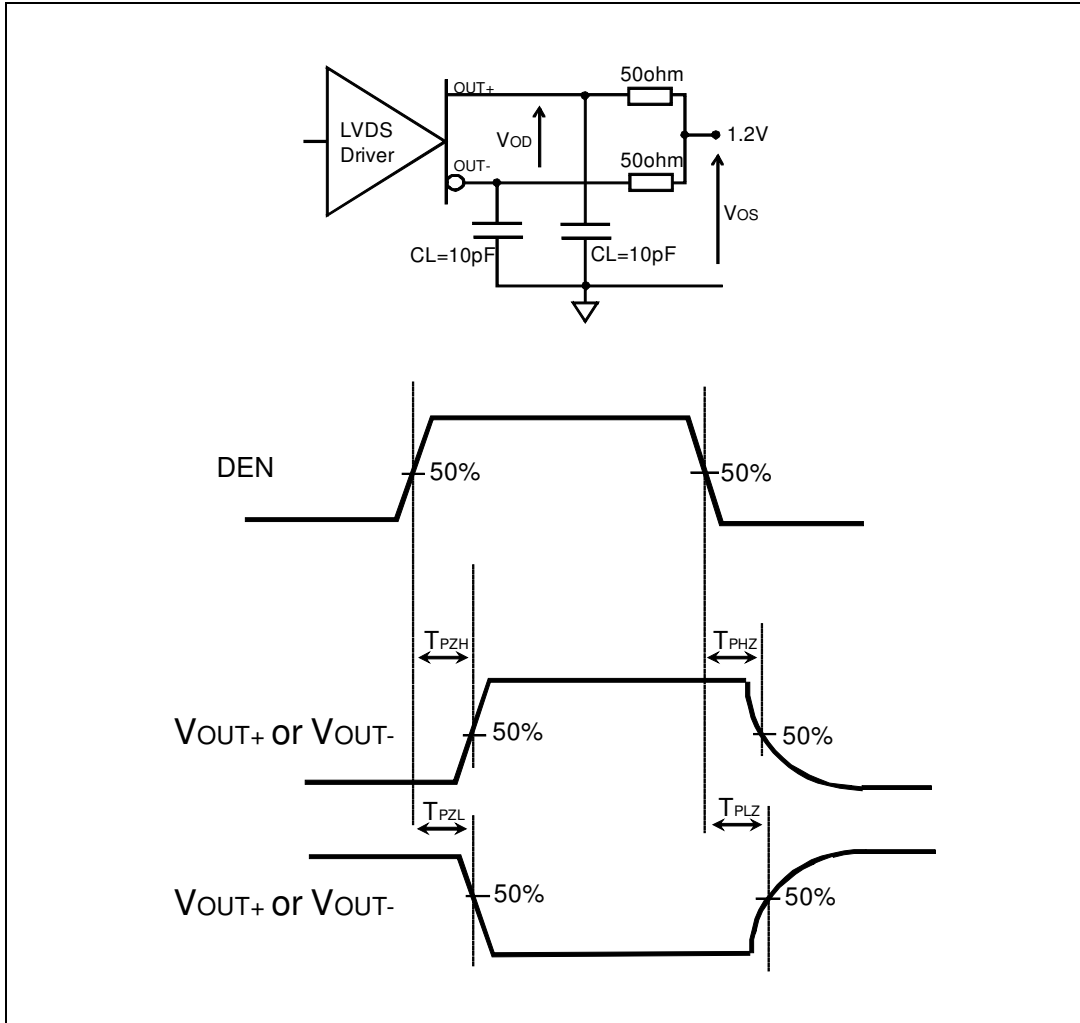

Figure 3. Test circuit, timing and voltage definitions for differential output signal



1. All input pulses are supplied by a generator with the following characteristics: t_r or $t_f \leq 1$ ns, $f = 1$ MHz, $Z_O = 50 \Omega$, and duty cycle = 50%.
2. The product is guaranteed in test with $CL = 10$ pF.

Figure 4. Enable and disable waveforms



1. All input pulses are supplied by a generator with the following characteristics: t_r or $t_f \leq 1$ ns, f_{REN} or $f_{DEN} = 500$ kHz, and pulse width REN or DEN = 500 ns.
2. The product is guaranteed in test with CL = 10 pF.

6 Test circuit for the receiver

Figure 5. Timing test circuit and waveforms

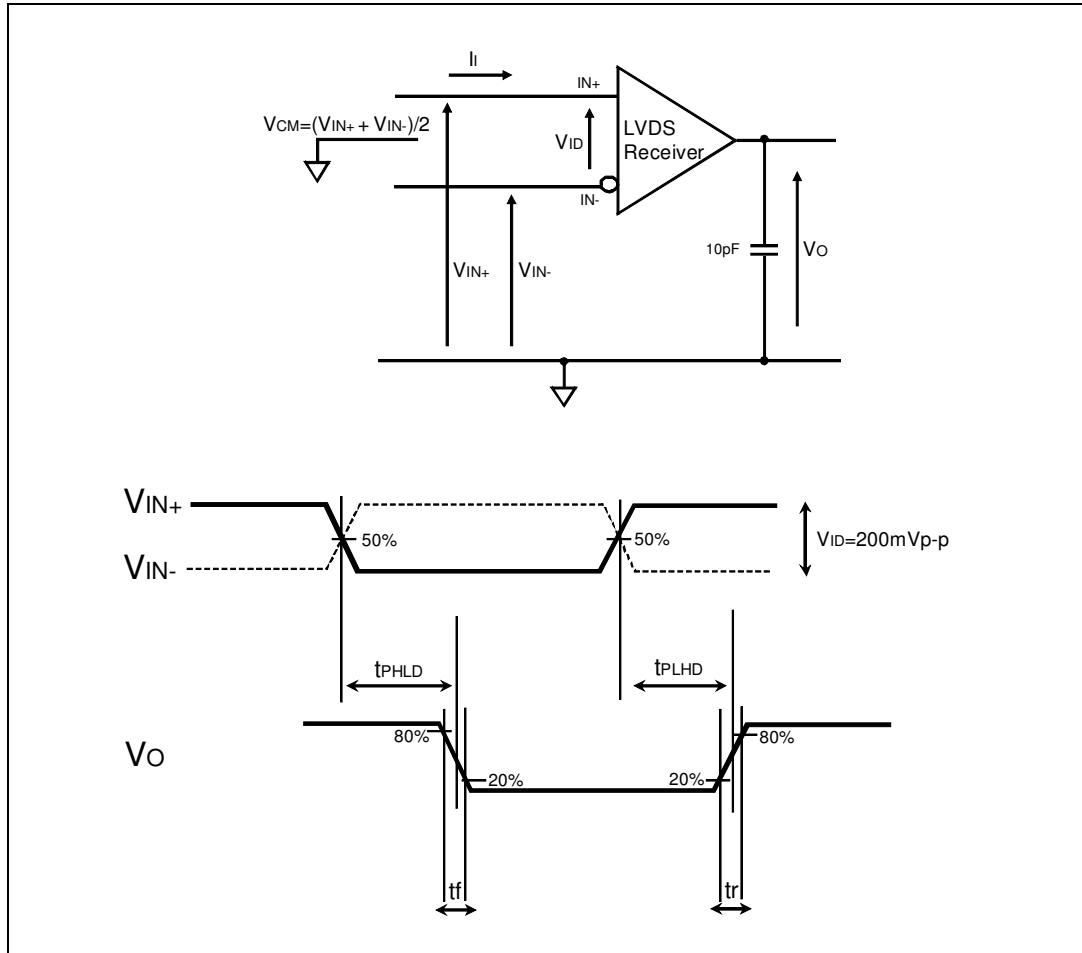

1. All input pulses are supplied by a generator with the following characteristics: t_r or $t_f \leq 1$ ns, $f = 1$ MHz, $Z_O = 50 \Omega$, and duty cycle = 50%.
2. The product is guaranteed in test with $C_L = 10$ pF.

Figure 6. Enable and disable waveforms

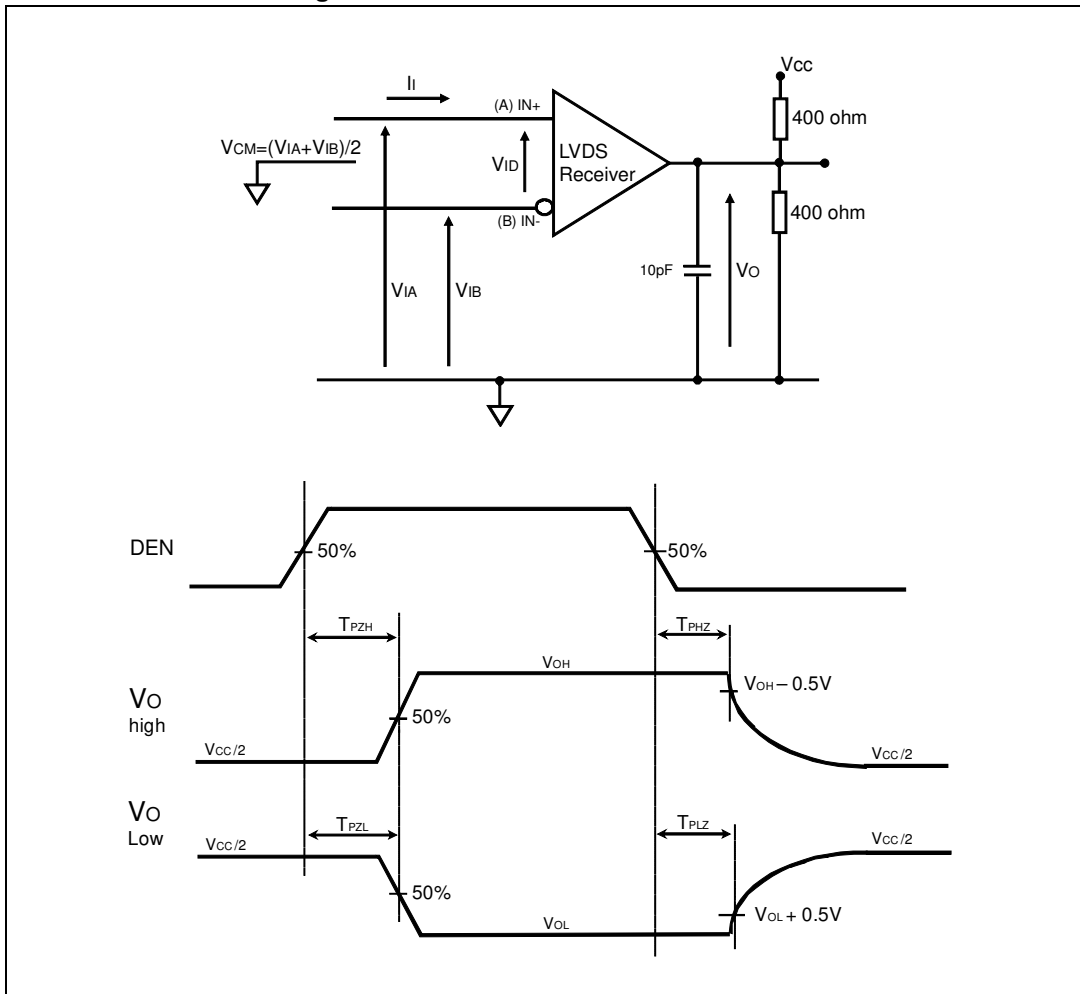

1. All input pulses are supplied by a generator with the following characteristics: t_r or $t_f \leq 1$ ns, f_G or $f_{\bar{G}} = 500$ kHz, and pulse width G or $\bar{G} = 500$ ns.
2. The product is guaranteed in test with $C_L = 10$ pF.

7 Package information

In order to meet environmental requirements, ST offers these devices in different grades of ECOPACK packages, depending on their level of environmental compliance. ECOPACK specifications, grade definitions, and product status are available at: www.st.com. ECOPACK is an ST trademark.

7.1 Ceramic Flat-18 package information

Figure 7. Ceramic Flat 18 package mechanical drawing

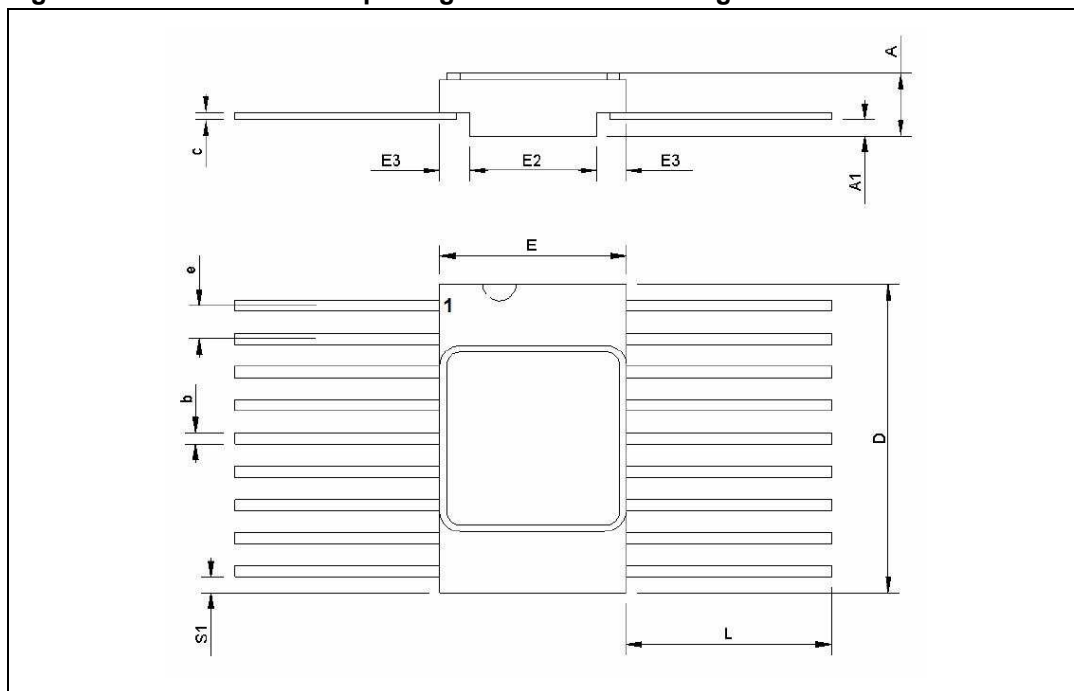

1. The upper metallic lid is electrically connected to ground.

Table 7. Ceramic Flat 18 package mechanical data

Ref.	Dimensions					
	Millimeters			Inches		
	Min.	Typ.	Max.	Min.	Typ.	Max.
A	2.18	2.46	2.74	0.86	0.097	0.108
A1	0.66	-	-	0.026	-	-
b	0.38	0.43	0.48	0.015	0.017	0.019
c	0.10	0.14	0.18	0.004	0.005	0.007
D	11.61	11.81	12.01	0.457	0.465	0.473
E	6.99	7.11	7.24	0.275	0.280	0.285
E2	4.67	4.82	4.98	0.184	0.19	0.196
E3	0.76	-	-	0.03	-	-
e	-	1.27	-	-	0.050	-
L	7.37	7.87	8.37	0.290	0.031	0.330
S1	0.13	-	-	0.005	-	-

8 Ordering information

Table 8. Order codes

Order code	SMD ⁽¹⁾	Quality level	Package	Lead-finish	Marking ⁽²⁾	Packing
RHFLVDSR2D2K1	-	Engineering model	Flat-18 with grounded lid	Gold	RHFLVDSR2D2K1	Tray
RHFLVDSR2D2K01V	5962F06202	QML-V Flight		Gold	5962F0620202VYC	
RHFLVDSR2D2K02V				Solder Dip	5962F0620202VYA	

- Standard microcircuit drawing.
- Specific marking only. Complete marking includes the following:
 - ST logo
 - Date code (date the package was sealed) in YYWWA (year, week, and lot index of week)
 - Country of origin (FR = France)

Note: *Contact your ST sales office for information about the specific conditions for products in die form.*

9 Shipping information

Date code

The date code (date the package was sealed) is structured as follows:

- Engineering model: 3yywwz
- Flight model: yywwz

Where:

yy = last two digits of the year, ww = week digits, z = lot index of the week

Product documentation

Each product shipment includes a set of associated documentation within the shipment box. This documentation depends on the quality level of the products, as detailed in [Table 9](#) below.

The Certificate of Conformance is provided on paper whatever the quality level. For QML parts, complete documentation, including the Certificate of Conformance, is provided on a CDROM.

Note: Contact ST for details on the documentation of other quality levels.

Table 9. Product documentation

Quality level	Item
Engineering Model	Certificate of Conformance including: <ul style="list-style-type: none"> - Customer name - Customer Purchase Order number - ST Sales Order number & Item - ST Part Number - Quantity delivered - Date Code - Reference to ST datasheet - Reference to TN1181 on Engineering Models - ST Rennes assembly lot ID
QML-V Flight	Certificate of Conformance including: <ul style="list-style-type: none"> - Customer name - Customer Purchase Order number - ST Sales Order number & Item - ST Part Number - Quantity delivered - Date Code - Serial numbers - Group C reference - Group D reference - Reference to the applicable SMD - ST Rennes assembly lot ID
	Quality Control Inspection (groups A, B, C, D, E)
	Screening electrical data in/out summary
	Precap report
	PIND test (Particle Impact Noise Detection)
	SEM inspection report (Scanning Electronic Microscope)
	X-Ray plates

10 Revision history

Table 10. Document revision history

Date	Revision	Changes
29-Oct-2013	1	Initial release
30-Oct-2014	2	<ul style="list-style-type: none"> – Updated production status and marking information relative to order code RHFLVDSR2D2K01V in Table 1: Device summary and Table 9: Order codes. – Removed row regarding CL parameter from Table 5: Operating conditions. – Changed title of Section 3 to “Radiation” and moved Electrical characteristics to Section 4. – Updated the maximum channel-to-channel skew value from 0.2 ns to 0.25 ns in Table 7.
04-Mar-2015	3	<ul style="list-style-type: none"> – Added V_{OUT} to Table 4: Absolute maximum ratings. – Added V_{CL} to Table 7: Electrical characteristics.
09-Nov-2023	4	<ul style="list-style-type: none"> – Added V_{IN} and V_{ID} in Table 4: Absolute maximum ratings.
25-Feb-2025	5	<ul style="list-style-type: none"> – Updated figure and features on the cover page, V_{ID} value in Table 3 and Chapter 9. – Added RHFLVDS32AK02V solder dip in Table 8.
29-May-2025	6	<ul style="list-style-type: none"> – Updated V_{TL} and V_{TH} test conditions in Table 6.
25-Mar-2026	7	<ul style="list-style-type: none"> – Updated packing in Table 8.

IMPORTANT NOTICE – PLEASE READ CAREFULLY

STMicroelectronics NV and its subsidiaries ("ST") reserve the right to make changes, corrections, enhancements, modifications, and improvements to ST products and/or to this document at any time without notice.

In the event of any conflict between the provisions of this document and the provisions of any contractual arrangement in force between the purchasers and ST, the provisions of such contractual arrangement shall prevail.

The purchasers should obtain the latest relevant information on ST products before placing orders. ST products are sold pursuant to ST's terms and conditions of sale in place at the time of order acknowledgment.

The purchasers are solely responsible for the choice, selection, and use of ST products and ST assumes no liability for application assistance or the design of the purchasers' products.

No license, express or implied, to any intellectual property right is granted by ST herein.

Resale of ST products with provisions different from the information set forth herein shall void any warranty granted by ST for such product.

If the purchasers identify an ST product that meets their functional and performance requirements but that is not designated for the purchasers' market segment, the purchasers shall contact ST for more information.

ST and the ST logo are trademarks of ST. For additional information about ST trademarks, please refer to www.st.com/trademarks. All other product or service names are the property of their respective owners.

Information in this document supersedes and replaces information previously supplied in any prior versions of this document.

© 2026 STMicroelectronics – All rights reserved