

Wired M-BUS Slave Transceiver

NCN5150

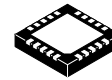

QFN20
MN SUFFIX
CASE 485E

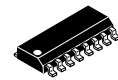

SOIC-16
D SUFFIX
CASE 751B

Description

The NCN5150 is a single-chip integrated slave transceiver for use in two-wire Meter Bus (M-BUS) slave devices and repeaters. The transceiver provides all of the functions needed to satisfy the European Standards EN 13757-2 and EN 1434-3 describing the physical layer requirements for M-BUS. It includes a programmable power level of up to 2 (SOIC version) or 6 (QFN version) unit loads, which are available for use in external circuits through a 3.3 V LDO regulator.

The NCN5150 can provide communication up to the maximum M-BUS communication speed of 38,400 baud (half-duplex).

Features

- Single-chip MBUS Transceiver
- UART Communication Speeds Up to 38,400 baud
- Integrated 3.3 V VDD LDO Regulator with Extended Peak Current Capability of 15 mA
- Supports Powering Slave Device from the Bus or from External Power Supply
- Adjustable I/O Levels
- Adjustable Constant Current Sink up to 2 or 6 Unit Loads Depending on the Package
- Low Bus Voltage Operation
- Extended Current Budget for External Circuits: at least 0.88 mA
- Polarity Independent
- Power-Fail Function
- Fast Startup – No External Transistor Required on STC Pin
- Industrial Ambient Temperature Range of -40°C to +85°C
- Available in:
 - ◆ 16-pin SOIC (Pin-to-Pin Compatible with TSS721A)
 - ◆ 20-pin QFN
- These are Pb-free Devices

Typical Applications

- Multi-energy Utility Meters
 - ◆ Water
 - ◆ Gas
 - ◆ Electricity
 - ◆ Heating systems

Related Standards – European Standard

EN 13757-2, EN 1434-3

For more information visit www.m-bus.com

MARKING DIAGRAMS

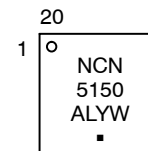

QFN20, 4x4

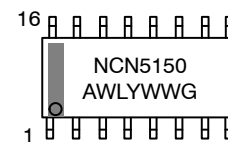

SOIC-16

- A = Assembly Location
- L, WL = Wafer Lot (optional)
- Y = Year
- W, WW = Work Week
- G or ■ = Pb-free Package

ORDERING INFORMATION

See detailed ordering and shipping information in the package dimensions section on page 11 of this data sheet.

NOTE: Some of the devices on this data sheet have been **DISCONTINUED**. Please refer to the table on page 11.

NCN5150

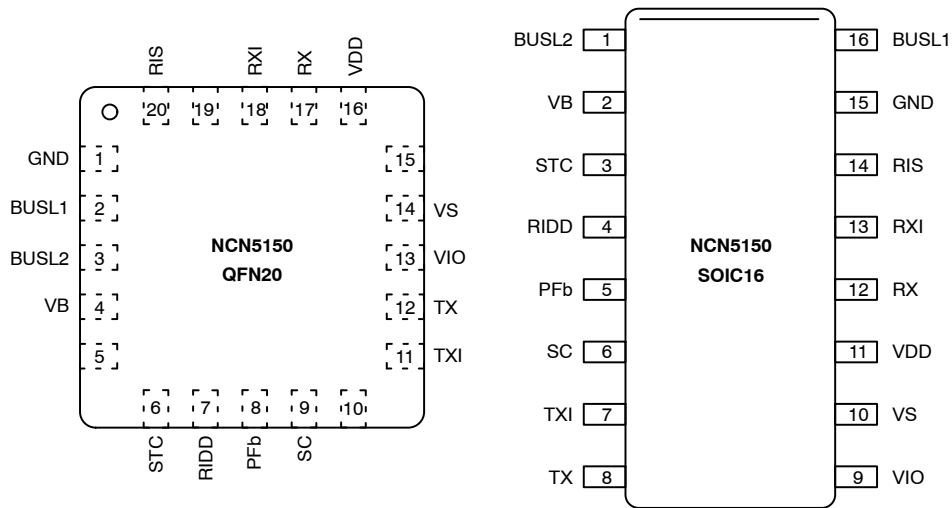

Figure 1. Pin Out NCN5150 in 20-pin NQFP and 16 Pin SOIC (Top View)

Table 1. NCN5150 PINOUT

Signal Name	Type	Pin Number		Pin Description
		NCN5150 SOIC	NCN5150 QFN	
BUSL1	Bus	16	2	MBUS line. Connect to bus through 220 Ω series resistors. Connections are polarity independent
BUSL2	Bus	1	3	
VB	Power	2	4	Rectified bus voltage
STC	Output	3	6	Storage capacitor pin. Connect to bulk storage capacitor (minimum 10 μ F, maximum 330 μ F–2,700 μ F – see Table 9)
RIDD	Input	4	7	Mark current adjustment pin. Connect to programming resistor
PFb	Output	5	8	Power Fail, active low
SC	Output	6	9	Mark bus voltage level storage capacitor pin. Connect to ceramic capacitor (typically 220 nF)
TXI	Output	7	11	UART Data output (inverted)
TX	Output	8	12	UART Data output
VIO	Input	9	13	I/O pins (RX, RXI, TX, TXI, PFb) high level voltage
VS	Output	10	14	Gate driver for PMOS switch between bus powered operation and external power supply
VDD	Power	11	16	Voltage regulator output. Connect to minimum 1 μ F decoupling capacitor
RX	Input	12	17	UART Data input
RXI	Input	13	18	UART Data input (inverted)
RIS	Input	14	20	Modulation current adjustment pin
GND	Ground	15	1	Ground
NC	NC	–	5, 10, 15, 19	Not connected pins. Tie to GND
EP	Ground	–	EP	Exposed Pad. Tie to GND

NCN5150

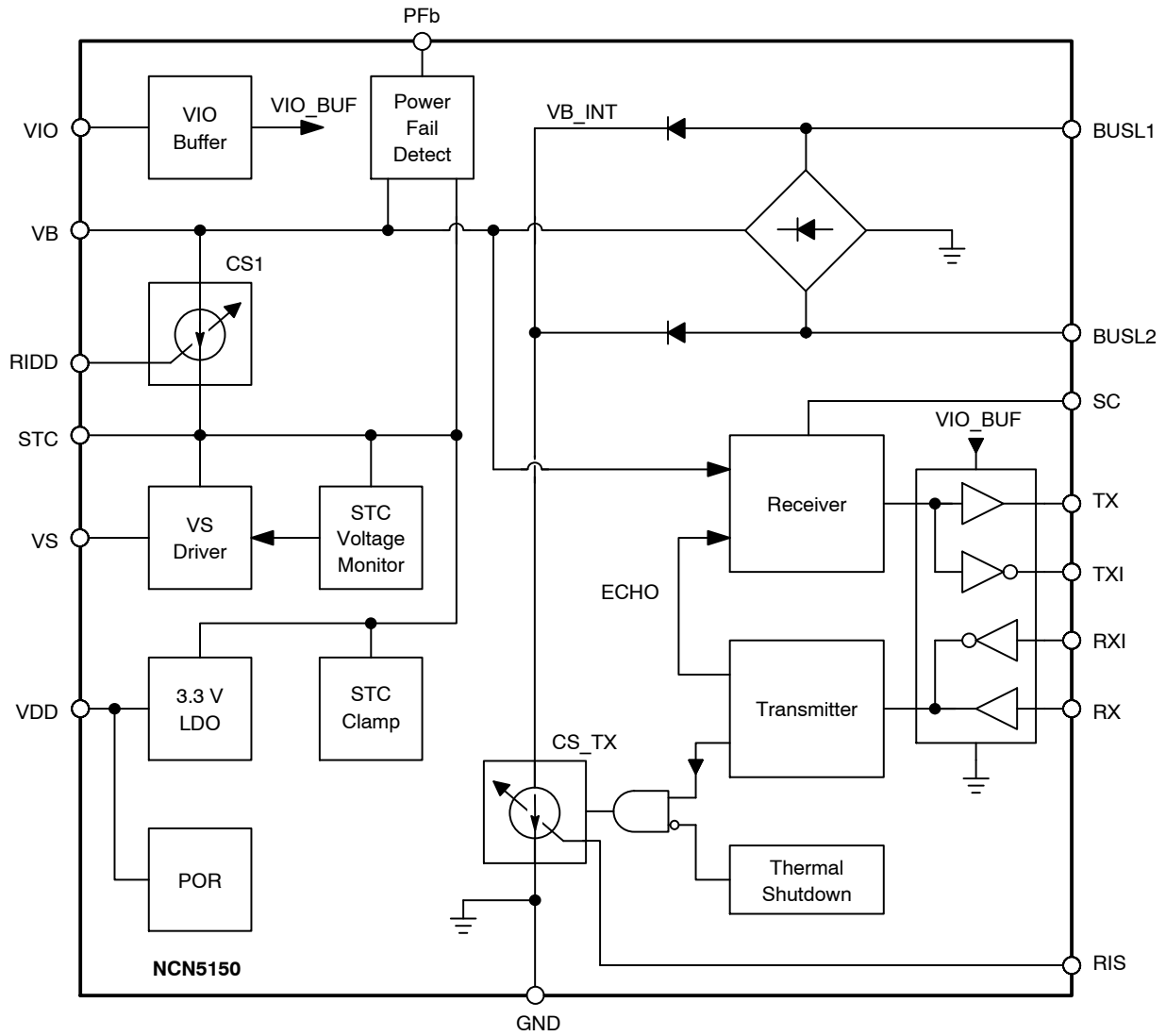

Figure 2. NCN5150 Block Diagram

Table 2. ABSOLUTE MAXIMUM RATINGS (Note 1)

Symbol	Parameter	Min	Max	Unit
T_J	Junction Temperature	-40	+150	°C
T_S	Storage Temperature	-55	+150	°C
V_{BUS}	Bus Voltage (BUSL1 - BUSL2)	-50	50	V
V_{TX}, V_{TXI}	Voltage on Pin TX, TXI	-0.3	7.5	V
V_{RX}, V_{RXI}, V_{IO}	Voltage on Pin RX, RXI, VIO	-0.3	5.5	V
ESD_{HBM}	ESD Rating - Human Body Model	4.0	-	kV
ESD_{MM}	ESD Rating - Machine Model	250	-	V
ESD_{CDM}	ESD Rating - Charged Device Model	750	-	V

Stresses exceeding those listed in the Maximum Ratings table may damage the device. If any of these limits are exceeded, device functionality should not be assumed, damage may occur and reliability may be affected.

1. All voltages are referenced to GND.

Table 3. THERMAL CHARACTERISTICS

Rating	Symbol	Typical Value	Unit
Thermal Characteristics, SOIC-16 – Thermal Resistance, Junction-to-Air	$R_{\theta JA}$	125	$^{\circ}C/W$
Thermal Characteristics, QFN20 – Thermal Resistance, Junction-to-Air	$R_{\theta JA}$	42	$^{\circ}C/W$

NOTE: $R_{\theta JA}$ obtained with 1S0P (SOIC) or 2S2P (QFN) test boards according to JEDEC JESD51 standard.

Table 4. RECOMMENDED OPERATING CONDITIONS (Notes 2 and 3)

Symbol	Parameter	Min	Max	Unit	
T_A	Ambient Temperature	-40	+85	$^{\circ}C$	
V_{BUS}	Bus Voltage ($V_{BUSL1} - V_{BUSL2}$)	1-2 Unit Loads	9.2	42	V
		3-6 Unit Loads	9.7	42	V
V_{IO}	VIO Pin Voltage (Note 4)	2.5	3.8	V	

2. Refer to ELECTRICAL CHARACTERISTICS and APPLICATION INFORMATION for Safe Operating Area.

3. All voltages are referenced to GND.

4. V_{STC} must be at least 1V higher than V_{IO} for proper operation.

Table 5. ELECTRICAL CHARACTERISTICS (Note 5)

Symbol	Parameter	Min	Typ	Max	Unit	
ΔV_{BR}	Voltage drop over bus rectifier ($V_{BUS} - V_B$) (R_{IDD} (Note 6) = 4.02 k Ω)	-	-	1.25	V	
ΔV_{CS}	Voltage drop over CS1 ($V_B - V_{STC}$)	R_{IDD} (Note 6) \geq 13 k Ω	1.30	-	-	V
		R_{IDD} (Note 6) \leq 4.02 k Ω	1.70	-	-	
I_{BUS}	Total Current Drawn from the Bus, Mark State	R_{IDD} (Note 6) = 30 k Ω	-	1.32	1.50	mA
		R_{IDD} (Note 6) = 13 k Ω	-	2.71	3.00	
		R_{IDD} (Note 6, 7) = 8.45 k Ω	-	4.10	4.50	
		R_{IDD} (Note 6, 7) = 6.19 k Ω	-	5.50	6.00	
		R_{IDD} (Note 6, 7) = 4.87 k Ω	-	6.80	7.50	
		R_{IDD} (Note 6, 7) = 4.02 k Ω	-	8.22	9.00	
ΔI_{BUS}	Bus Current Stability (over $\Delta V_{BUS} = 10$ V, RX/RXI = mark)	-	0.2	2	%	
I_{STC}	Idle Current Available for the Application to Draw from STC and V_{DD} (Including Current Drawn from IO Pins)	R_{IDD} (Note 6) = 30 k Ω	0.88	1.05	1.20	mA
		R_{IDD} (Note 6) = 13 k Ω	2.10	2.35	2.60	
		R_{IDD} (Note 6, 7) = 8.45 k Ω	3.10	3.60	4.00	
		R_{IDD} (Note 6, 7) = 6.19 k Ω	4.20	4.80	5.40	
		R_{IDD} (Note 6, 7) = 4.87 k Ω	5.30	6.10	6.90	
		R_{IDD} (Note 6, 7) = 4.02 k Ω	6.50	7.45	8.40	
$\Delta I_{STC, space}$	Additional Current Available for the Application when Transmitting a Space	-	200	-	μA	
I_{CC}	Internal Supply Current (R_{IDD} (Note 6) = 13 k Ω , RX/RXI = mark)	-	359	500	μA	
I_{IO}	Current Drawn by the V_{IO} Pin	-0.5	-	0.5	μA	
$V_{STC, clamp}$	Clamp Voltage on Pin STC ($I_{DD} < I_{STC}$)	6.0	6.5	7.0	V	
$V_{B, PFb}$	Threshold Voltage on V_B to Trigger PFb (Note 8)	$V_{STC} + 0.3$	-	$V_{STC} + 0.8$	V	
$V_{PFb, OH}$	PFb Voltage High ($I_{PFb} = -100 \mu A$)	$V_{IO} - 0.6$	-	V_{IO}	V	
$V_{PFb, OL}$	PFb Voltage Low (Note 9) ($I_{PFb} = 50 \mu A$)	0	-	0.6	V	
V_{RIDD}	Voltage on RIDD Pin	1.15	1.20	1.25	V	
$V_{VS, OH}$	Voltage on VS during High State ($V_{STC} > V_{STC}$, $V_{DD ON}$, $I_{VS} = -5 \mu A$)	$V_{STC} - 0.4$	-	V_{STC}	V	
$R_{VS, PD}$	Pull-down Resistor on VS during Low State ($V_{DD} > 2$ V, $V_{STC} > V_S$)	50	100	150	k Ω	

5. All voltages are referenced to GND.

6. Resistor with 1% accuracy.

7. Only possible in NQFP variant.

8. PFb comparator has a 70 mV hysteresis.

9. PFb pin is pulled down with an on-chip resistor of typically 2 M Ω .

Table 6. VDD REGULATOR ELECTRICAL CHARACTERISTICS (Note 10)

Symbol	Parameter	Min	Typ	Max	Unit
V _{DD}	Voltage on V _{DD} (Note 11) (I _{DD} < 15 mA)	3.1	3.3	3.6	V
I _{DD}	Peak Current that can be Supplied by V _{DD} (Note 12)	15	–	–	mA
I _{DD, OFF}	V _{BUS} = 0 V, V _{STC} = 0 V	–0.5	–	0.5	μA
V _{POR, ON}	Power-on Reset Threshold, Release	2.65	2.85	3.15	V
V _{POR, OFF}	Power-on Reset Threshold, Reset	2.55	2.75	3.00	V
V _{STC, VDD ON}	Threshold Voltage on Pin STC to Turn On V _{DD} Regulator, Pull the VS Pin High and Enable the PF Function	5.6	6.0	6.4	V
V _{STC, VDD OFF}	Threshold Voltage on Pin STC to Turn Off V _{DD} Regulator and Pull the PFb and VS Pins Low	3.7	4.0	4.3	V

10. All voltages are referenced to GND.

11. Including output resistance of V_{DD}.

12. Average current draw limited by I_{STC}.

Table 7. RECEIVER ELECTRICAL CHARACTERISTICS (Note 13)

Symbol	Parameter	Min	Typ	Max	Unit	
V _T	Receiver Threshold Voltage	V _{SC} – 8.2	–	V _{SC} – 5.7	V	
V _{SC}	Mark Level Storage Capacitor Voltage	–	–	V _B	V	
I _{SC, charge}	Mark Level Storage Capacitor Charge Current	–40	–25	–15	μA	
I _{SC, discharge}	Mark Level Storage Capacitor Discharge Current	0.3	0.6	–0.033 × I _{SC, charge}	μA	
CDR	Charge/Discharge Current Ratio	30	40	–		
V _{TX, OH, VTXI, OH}	TX/TXI High-level Voltage (I _{TX} /I _{TXI} = –100 μA) (Note 14)	V _{IO} – 0.6	–	V _{IO}	V	
V _{TX, OL, VTXI, OL}	TX/TXI Low-level Voltage	(I _{TX} /I _{TXI} = 100 μA)	0	–	0.35	V
		(I _{TX} = 1.1 mA)	0	–	1.5	V
I _{TX, ITXI}	V _{TX} = 7.5 V, V _{STC} = 6 V	0	–	16	μA	

13. All voltages are referenced to GND.

14. V_{STC} must be at least 1 V higher than V_{IO} for proper operation.

Table 8. TRANSMITTER ELECTRICAL CHARACTERISTICS (Note 15)

Symbol	Parameter	Min	Typ	Max	Unit
I _{MC}	Space Level Modulating Current (R _{RIS} = 100 Ω (Note 16))	12.5	15.0	18.0	mA
V _{RIS}	Voltage on RIS Pin	1.2	1.4	1.6	V
V _{RX, IH, VRXI, IH}	RX/RXI Input High	V _{IO} – 0.8	–	5.5	V
V _{RX, IL, VRXI, IL}	RX/RXI Input Low	0	–	0.8	V
I _{RX, IRXI}	Current Drawn or Sourced from RX/RXI Pins (Note 17) (V _{IO} = 3 V)	±6	–	±30	μA

15. All voltages are referenced to GND.

16. Resistor with 1% accuracy.

17. Including internal pull-up resistor on RX and internal pull-down resistor on RXI.

NCN5150

APPLICATION SCHEMATICS

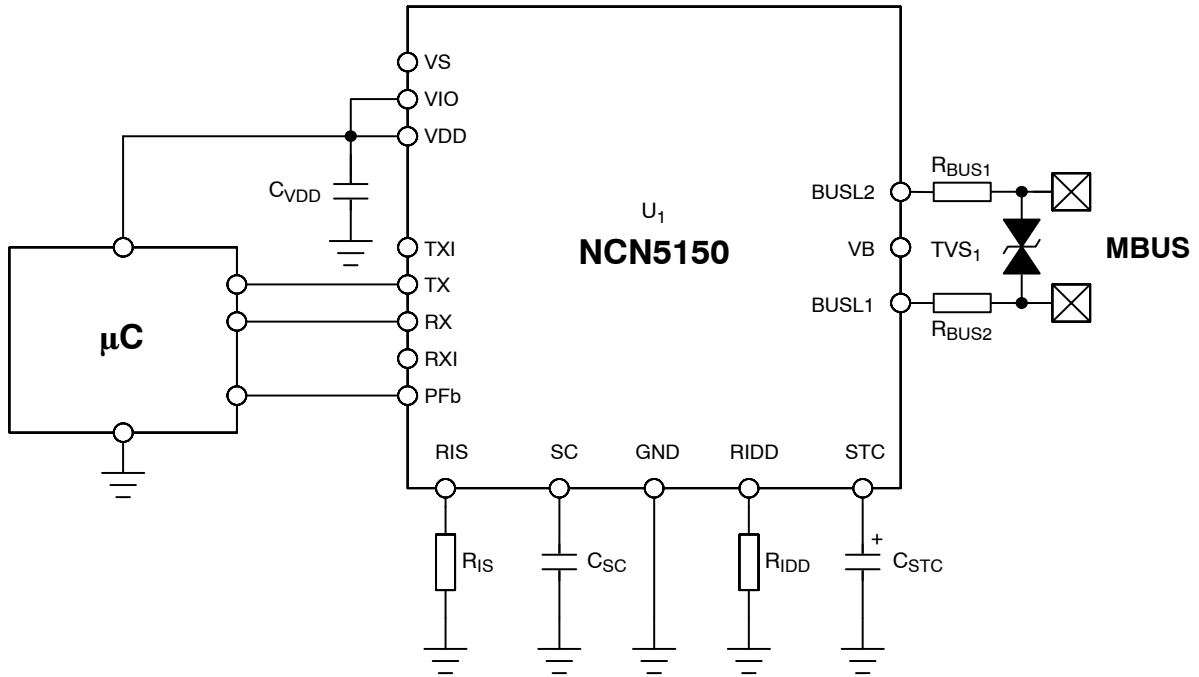

Figure 3. General Application Schematic

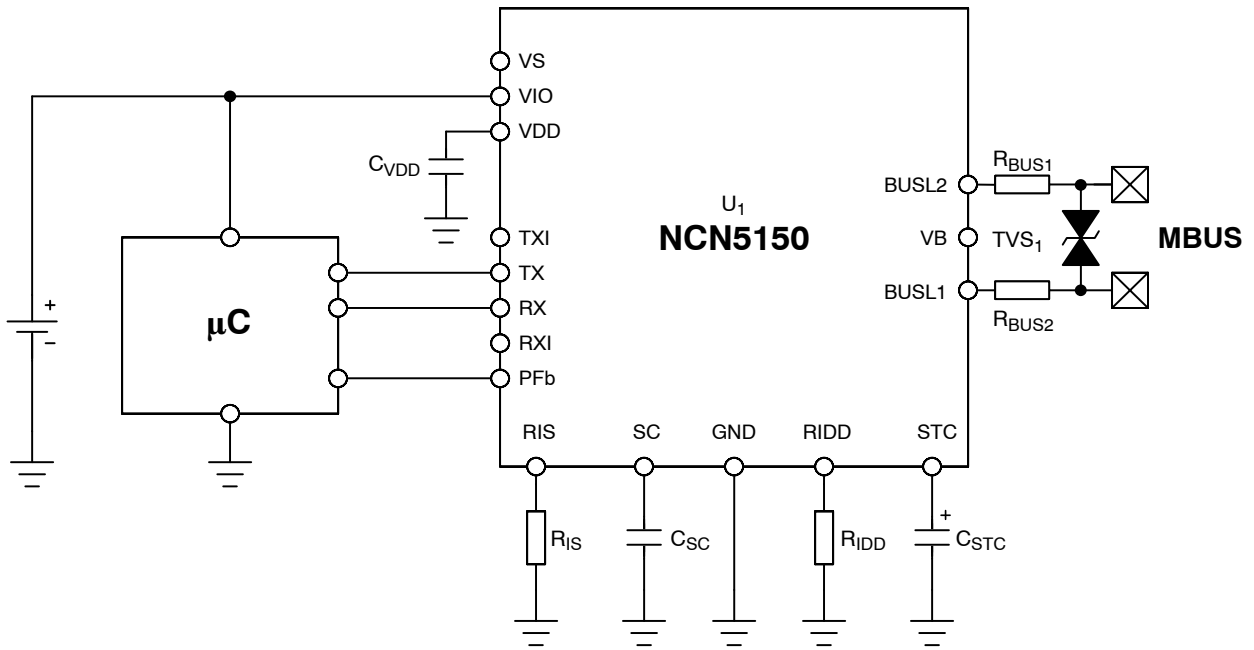

Figure 4. Application Schematic with External Power Supply (Battery)

NCN5150

APPLICATION SCHEMATICS

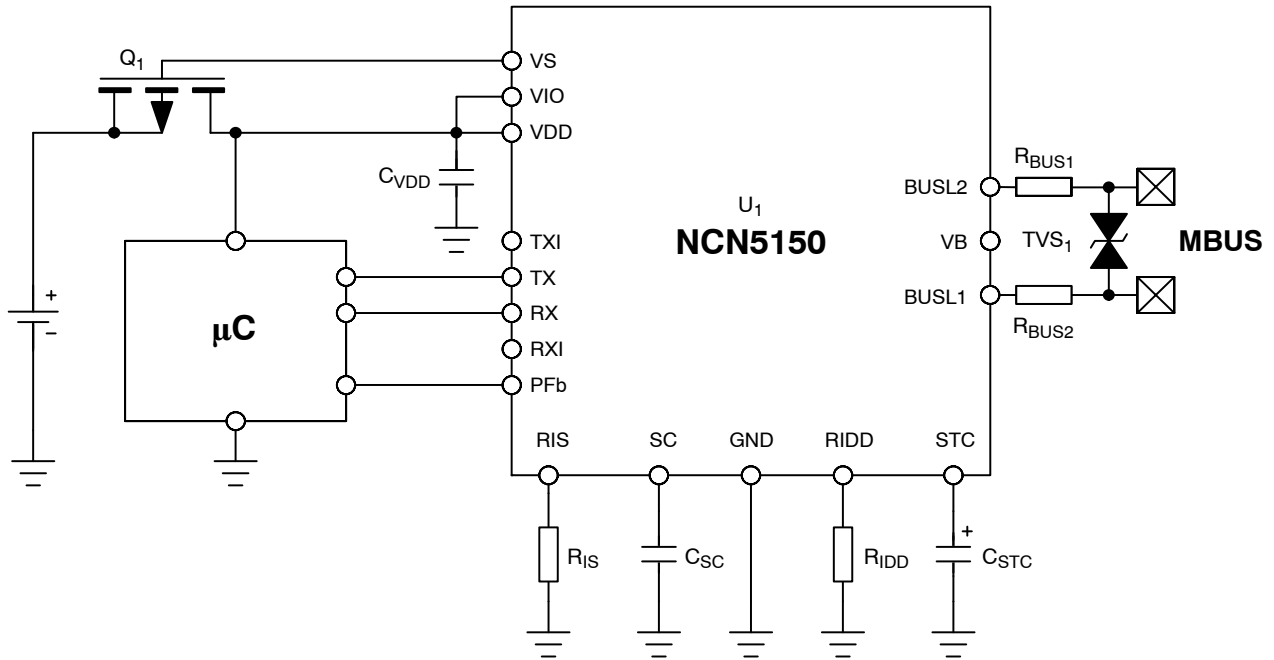

Figure 5. Application Schematic with Backup External Power Supply

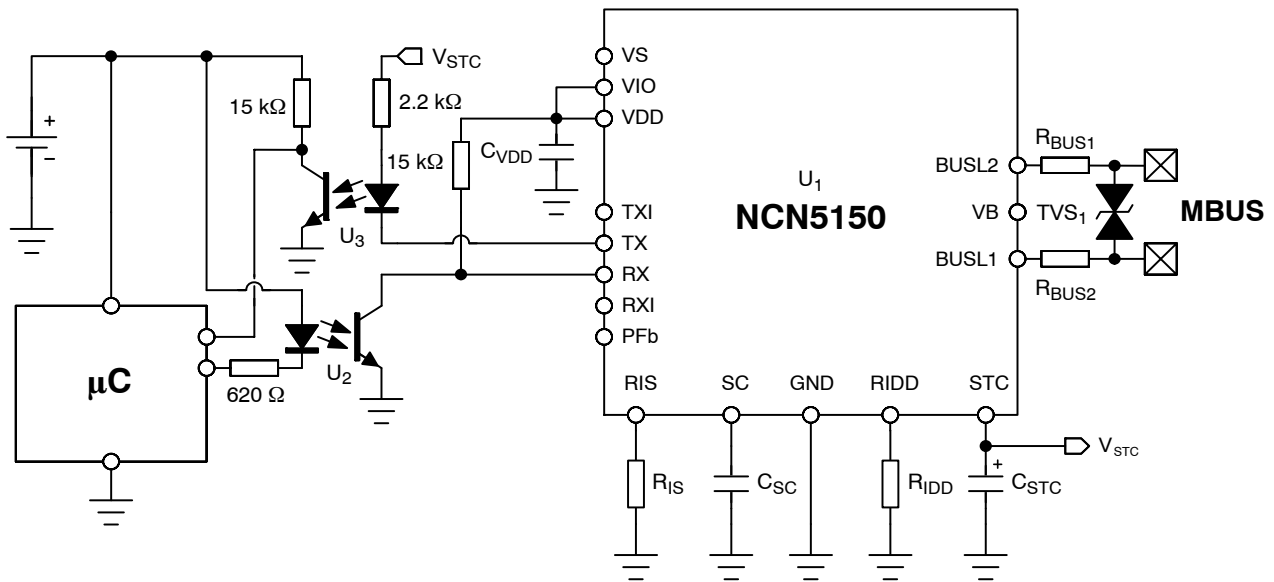

Figure 6. Optically Isolated Application Schematic

Table 9. TYPICAL BILL OF MATERIALS

Reference Designator	Value (Typical)	Tolerance	Manufacturer	Part Number
U ₁	–	–	ON Semiconductor	NCN5150
TVS ₁	40 V	–	ON Semiconductor	1SMA40CAT3G
C _{VDD}	> 1 μF	–20%, +80%		
R _{IS}	100 Ω	1%		
C _{SC}	220 nF	–20%, +80%		
R _{BUS1} , R _{BUS2}	220 Ω	10%		
R _{IDD}	1 UL	30 kΩ	1%	
	2 UL	13 kΩ	1%	
	3 UL (Note 18)	8.45 kΩ	1%	
	4 UL (Note 18)	6.19 kΩ	1%	
	5 UL (Note 18)	4.87 kΩ	1%	
	6 UL (Note 18)	4.02 kΩ	1%	
C _{STC}	1 UL	≤ 330 μF	10%	
	2 UL	≤ 820 μF	10%	
	3 UL (Note 18)	≤ 1,200 μF	10%	
	4 UL (Note 18)	≤ 1,500 μF	10%	
	5 UL (Note 18)	≤ 2,200 μF	10%	
	6 UL (Note 18)	≤ 2,700 μF	10%	

18.3–6 UL configurations are only possible for the NQFP variant.

APPLICATION INFORMATION

The NCN5150 is a slave transceiver for use in the meter bus (M-BUS) protocol. The bus connection is fully polarity independent. The transceiver will translate the bus voltage modulation from master-to-slave communication to TTL UART communication, and in the other direction translate UART voltage levels to bus current modulation. The transceiver also integrates a voltage regulator for utilizing the current drawn in this way from the bus, and an early power fail warning. The transceiver also supports an external power supply and the I/O high level can be set to match the slave sensor circuit. A complete block diagram is shown in Figure 2. Each section will be explained in more detail below.

Meter Bus Protocol

M-BUS is a European standard for communication and powering of utility meters and other sensors. Communication from master to slave is achieved by voltage-level signaling. The master will apply a nominal +36 V to the bus in idle state, or when transmitting a logical 1 (“mark”). When transmitting a logical 0 (“space”), the master will drop the bus voltage to a nominal +24 V.

Communication from the slave to the master is achieved by current modulation. In idle mode or when transmitting a logical 1 (“mark”), the slave will draw a fixed current from the bus. When transmitting a logical 0 (“space”), the slave will draw an extra nominal 15 mA from the bus. M-BUS uses a half-duplex 11-bit UART frame format, with 1 start

bit, 8 data bits, 1 even parity bit, and a stop bit. Communication speeds allowed by the M-BUS standard are 300, 600, 2400, 4800, 9600, 19200 and 38400 baud, all of which are supported by the NCN5150.

Bus Connection and Rectification

The bus should be connected to the pins BUSL1 and BUSL2 through series resistors to limit the current drawn from the bus in case of failure (according to the M-BUS standard). Typically, two 220 Ω resistors are used for this purpose.

Since the M-BUS connection is polarity independent, the NCN5150 will first rectify the bus voltage through an active diode bridge.

Slave Power Supply (Bus Powered)

A slave device can be powered by the M-BUS or from an external supply. The M-BUS standard requires the slave to draw a fixed current from the bus. This is accomplished by the constant current source CS1. This current is used to charge the external storage capacitor C_{STC}. The current drawn from the bus is defined by the programming resistor R_{IDD}. The bus current can be chosen in increments of 1.5 mA called unit loads. Table 5 list the different values of programming resistors needed for different unit loads, as well as the current drawn from the bus (I_{BUS}) and the current that can be drawn from the STC pin (I_{STC}). I_{STC} is slightly less than I_{BUS} to account for the internal power consumption

of the NCN5150. The R_{IDD} resistor used must be at least 1% accurate. Note that using 5 and 6 Unit Loads is not covered by the M-BUS standard.

When the voltage on the STC pin reaches V_{STC} , VDD ON the LDO is turned on, and will regulate the voltage on the VDD pin to 3.3 V, drawing current from the storage capacitor. A decoupling capacitor of minimum 1 μ F is required on the VDD pin for stability of the regulator. On the STC pin, a minimum capacitance of 10 μ F is required. Furthermore, the ratio C_{STC}/C_{VDD} must be larger than 9. The voltage on the STC pin is clamped to $V_{STC, clamp}$ by a shunt regulator, which will dissipate any excess current that is not used by the NCN5150 or external circuits.

Slave Power Supply (External)

In case the external sensor circuit consumes more than the allowed bus current or the sensor should be kept operational when the bus is not present, an external power supply, such as a battery, is required.

When the external circuitry uses different logical voltage levels, simply connect the power supply of that voltage level to V_{IO} , so that the RX, RXI, TX, TXI and Pfb pins will respond to the correct voltage levels. The NCN5150 will still be powered from the bus, but all communication will be translated to the voltage level of V_{IO} .

If the external power supply should be used only as a backup when the bus power supply fails, a PMOS transistor can be inserted between the external power supply and VDD as shown in Figure 5. The gate is connected to VS, and will be driven high when the voltage on STC goes above the turn-on threshold of the LDO, nl. $V_{STC, VDD ON}$. For more information see the paragraph on the power on sequence and corresponding Figure 12 on page 10.

Communication, Master to Slave

M-BUS communication from master to slave is based on voltage level signaling. To differentiate between master signaling and voltage drop caused by the signaling of another slave over cabling resistance, etc., the mark level $V_{BUS, MARK}$ is stored, and only when the bus voltage drops to less than V_T will the NCN5150 detect communication. A simplified schematic of the receiver is shown in Figure 8. The received data is transmitted on the pins TX and TXI, as shown in the waveforms of Figure 7.

An external capacitor must be connected to the SC pin to store the mark voltage level. This capacitor is charged to V_B . Discharging of this capacitor is typically 40x slower, so that the voltage on SC drops only a little during the time the master is transmitting a space. The value of C_{SC} must be chosen in the range of 100 nF–330 nF.

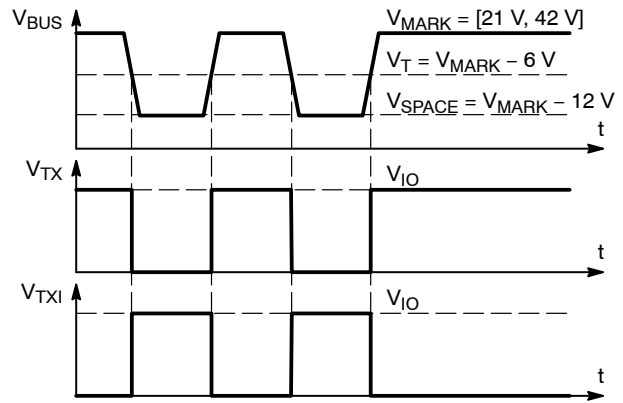

Figure 7. Communication, Master to Slave

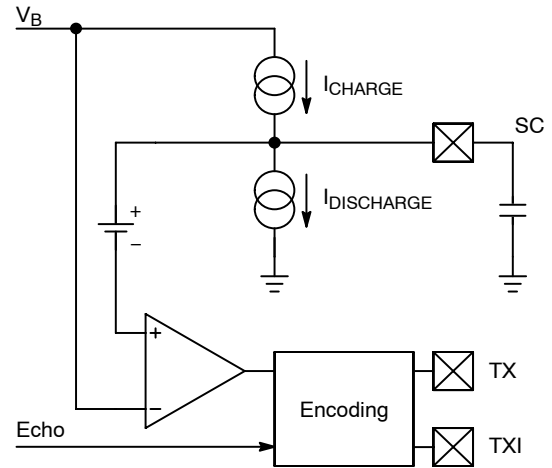

Figure 8. Communication, Master to Slave

Communication, Slave to Master

M-BUS communication from slave to master uses bus current modulation while the voltage remains constant. This current modulation can be controlled from either the RX or RXI pin as shown in Figure 10. When transmitting a space (“0”), the current modulator will draw an additional current from the bus. This current can be set with a programming resistor R_{RIS} . To achieve the space current required the M-BUS standard, R_{RIS} should be 100 Ω . A simplified schematic of the transmitter is shown in Figure 11.

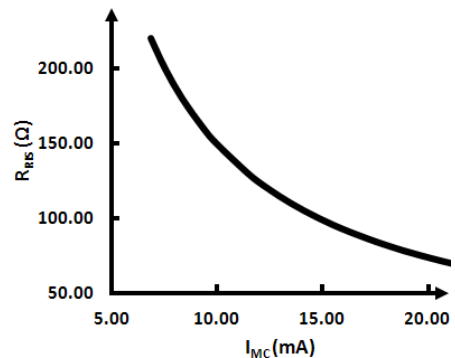

Figure 9. Typical Relationship between RIS and Current Modulation Level

Because the M-BUS protocol is specified as half-duplex, an echo function will cause the transmitted signal on RX or RXI to appear on the receiver outputs TX and TXI. Should the master attempt to send at the same time, the bitwise added signal of both sources will appear on these pins, resulting in invalid data.

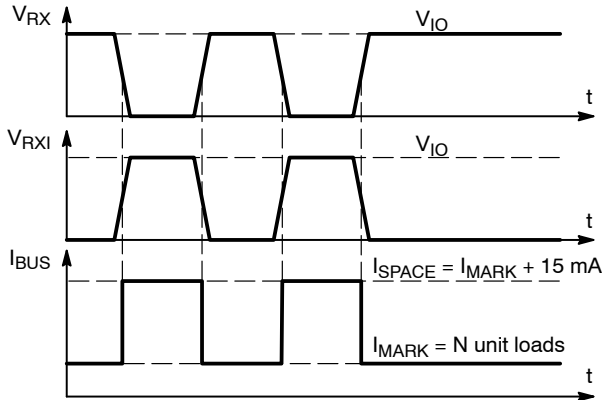

Figure 10. Communication, Slave to Master

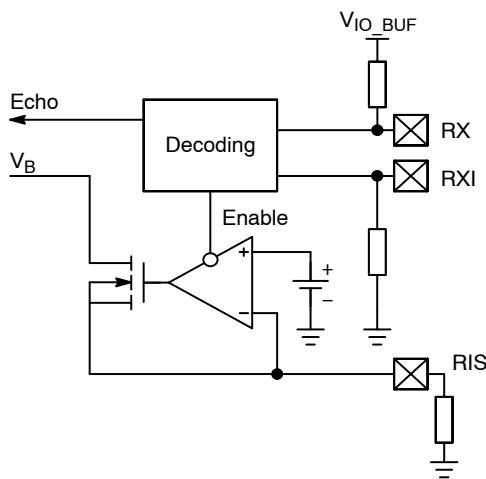

Figure 11. Communication, Slave to Master

Power On/Off Sequence

The power-on and power-off sequence of the NCN5150 is shown in Figure 12. Shown also in Figure 12 is the operation of the PFb pin. This pin is used to give an early warning to the microcontroller that the bus power is collapsing, allowing the microcontroller to save its data and

shut down gracefully. The times t_{on} and t_{off} can be approximated by the following formulas:

$$t_{on} = \frac{C_{STC}}{I_{STC}} V_{STC, VDD ON} \quad (eq. 1)$$

$$t_{off} = \frac{C_{STC}}{I_{CC} + I_{DD}} (V_{STC, Clamp} - V_{STC, VDD OFF}) \quad (eq. 2)$$

Where I_{CC} is the internal current consumption of the NCN5150 and I_{DD} is the current consumed by external circuits drawn from either VDD or STC.

These formulas can be used to dimension the value of the bulk C_{STC} needed, taking into account that the M-BUS standard requires t_{on} to be less than 3 s.

For certain applications where the power drawn from the bus is not used in external circuits, the storage capacitor value can be much lower. The NCN5150 requires a minimum STC capacitance of 10 μ F to ensure that the bus current regulation is stable under all conditions.

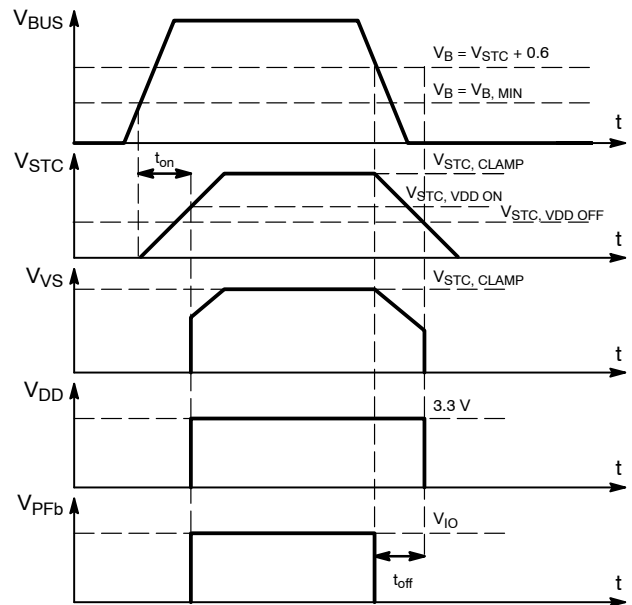

Figure 12. Power-on and Power-off

Thermal Shutdown

The NCN5150 includes a thermal shutdown function that will disable the transmitter when the junction temperature of the IC becomes too hot. The thermal protection is only active when the slave is transmitting a space to the master.

NCN5150

Table 10. ORDERING INFORMATION

Device	Package	Shipping†
NCN5150MNTWG	QFN20, 4x4 (Pb-free)	2,500 / Tape & Reel

DISCONTINUED (Note 19)

NCN5150DG	SOIC16 (Pb-free)	48 Units / Tube
NCN5150DR2G		3,000 / Tape & Reel

†For information on tape and reel specifications, including part orientation and tape sizes, please refer to our Tape and Reel Packaging Specifications Brochure, BRD8011/D.

19. **DISCONTINUED:** These devices are not recommended for new design. Please contact your **onsemi** representative for information. The most current information on these devices may be available on www.onsemi.com.



SCALE 2:1

QFN20, 4x4, 0.5P
CASE 485E
ISSUE C

DATE 13 FEB 2018

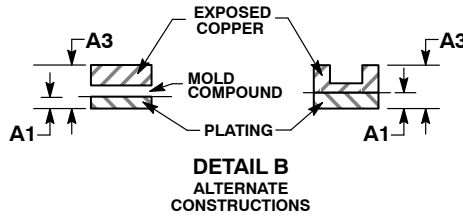
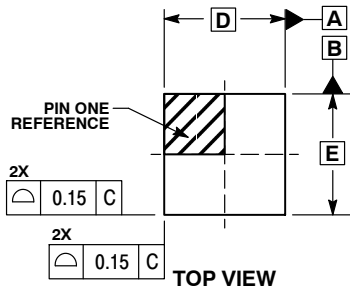

NOTES:

1. DIMENSIONING AND TOLERANCING PER ASME Y14.5M, 1994.
2. CONTROLLING DIMENSION: MILLIMETERS.
3. DIMENSION b APPLIES TO PLATED TERMINAL AND IS MEASURED BETWEEN 0.15 AND 0.30 MM FROM THE TERMINAL TIP.
4. COPLANARITY APPLIES TO THE EXPOSED PAD AS WELL AS THE TERMINALS.

MILLIMETERS		
DIM	MIN	MAX
A	0.80	1.00
A1	---	0.05
A3	0.20	REF
b	0.20	0.30
D	4.00	BSC
D2	2.60	2.90
E	4.00	BSC
E2	2.60	2.90
e	0.50	BSC
K	0.20	REF
L	0.35	0.45
L1	0.00	0.15

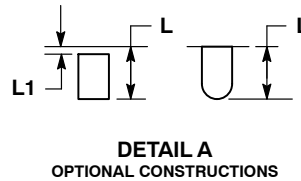
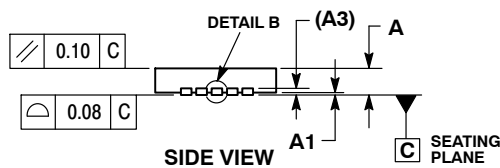

GENERIC
MARKING DIAGRAM*

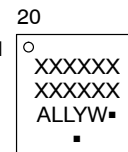
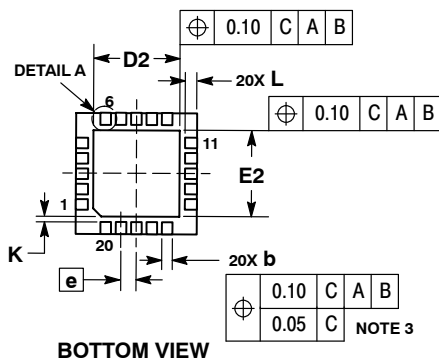

- XXXXXX= Specific Device Code
- A = Assembly Location
- LL = Wafer Lot
- Y = Year
- W = Work Week
- = Pb-Free Package

(Note: Microdot may be in either location)

SOLDERING FOOTPRINT*

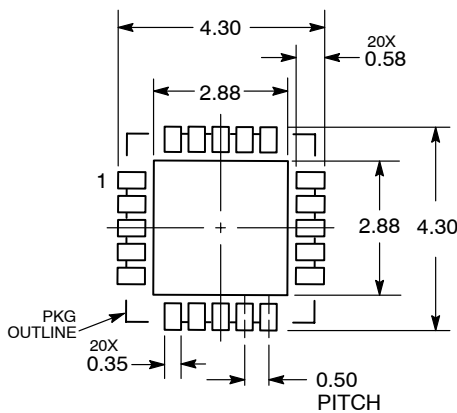

DIMENSIONS: MILLIMETERS

*For additional information on our Pb-Free strategy and soldering details, please download the onsemi Soldering and Mounting Techniques Reference Manual, SOLDERM/D.

DOCUMENT NUMBER:	98AON03163D	Electronic versions are uncontrolled except when accessed directly from the Document Repository. Printed versions are uncontrolled except when stamped "CONTROLLED COPY" in red.
DESCRIPTION:	QFN20, 4X4, 0.5P	PAGE 1 OF 1

onsemi and onsemi are trademarks of Semiconductor Components Industries, LLC dba onsemi or its subsidiaries in the United States and/or other countries. onsemi reserves the right to make changes without further notice to any products herein. onsemi makes no warranty, representation or guarantee regarding the suitability of its products for any particular purpose, nor does onsemi assume any liability arising out of the application or use of any product or circuit, and specifically disclaims any and all liability, including without limitation special, consequential or incidental damages. onsemi does not convey any license under its patent rights nor the rights of others.

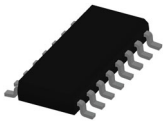

SOIC-16 9.90x3.90x1.37 1.27P
CASE 751B
ISSUE M

DATE 18 OCT 2024

NOTES:

1. DIMENSIONING AND TOLERANCING PER ASME Y14.5M, 2018.
2. DIMENSION IN MILLIMETERS. ANGLE IN DEGREES.
3. DIMENSIONS D AND E1 DO NOT INCLUDE MOLD PROTRUSION.
4. MAXIMUM MOLD PROTRUSION 0.15mm PER SIDE.
5. DIMENSION b DOES NOT INCLUDE DAMBAR PROTRUSION. ALLOWABLE DAMBAR PROTRUSION SHALL BE 0.127mm TOTAL IN EXCESS OF THE b DIMENSION AT MAXIMUM MATERIAL CONDITION.

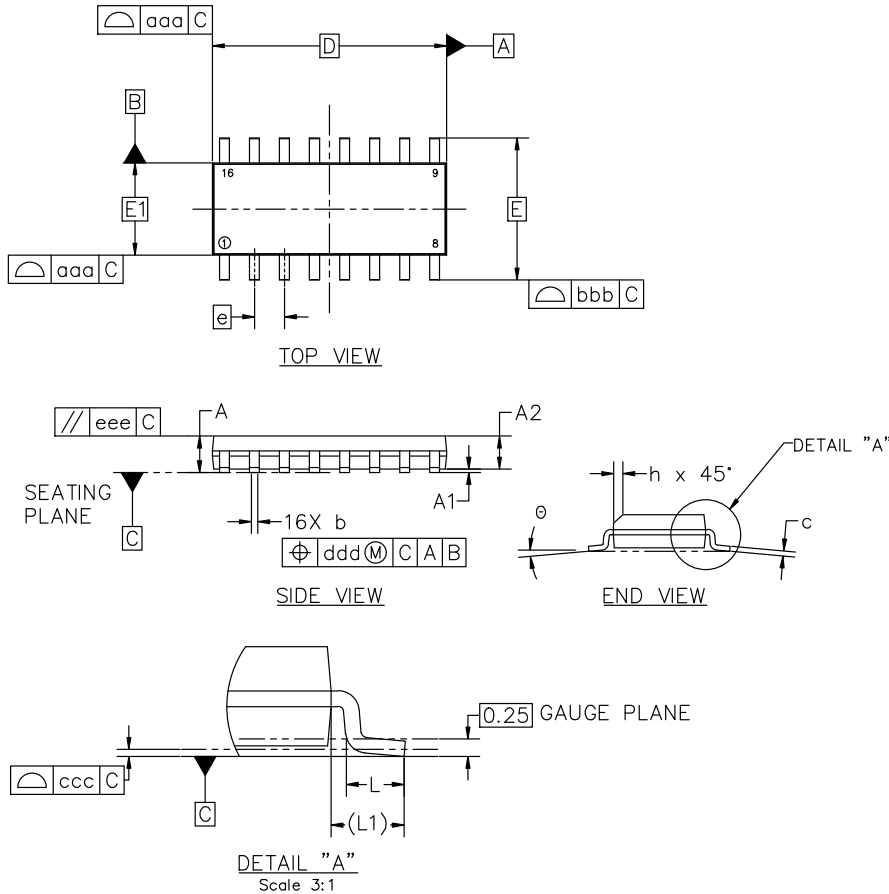

MILLIMETERS			
DIM	MIN	NOM	MAX
A	1.35	1.55	1.75
A1	0.10	0.18	0.25
A2	1.25	1.37	1.50
b	0.35	0.42	0.49
c	0.19	0.22	0.25
D	9.90 BSC		
E	6.00 BSC		
E1	3.90 BSC		
e	1.27 BSC		
h	0.25	---	0.50
L	0.40	0.83	1.25
L1	1.05 REF		
θ	0°	---	7°
TOLERANCE OF FORM AND POSITION			
aaa	0.10		
bbb	0.20		
ccc	0.10		
ddd	0.25		
eee	0.10		

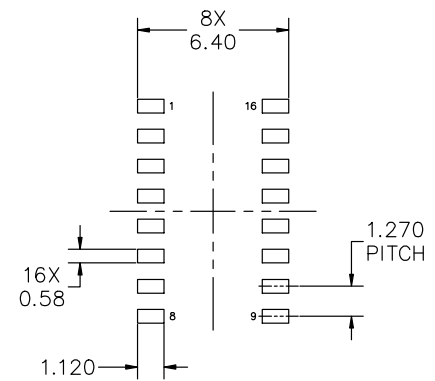

RECOMMENDED MOUNTING FOOTPRINT

*FOR ADDITIONAL INFORMATION ON OUR PB-FREE STRATEGY AND SOLDERING DETAILS, PLEASE DOWNLOAD THE onsemi SOLDERING AND MOUNTING TECHNIQUES REFERENCE MANUAL, SOLDERRM/D

DOCUMENT NUMBER:	98ASB42566B	Electronic versions are uncontrolled except when accessed directly from the Document Repository. Printed versions are uncontrolled except when stamped "CONTROLLED COPY" in red.
DESCRIPTION:	SOIC-16 9.90X3.90X1.37 1.27P	PAGE 1 OF 2

onsemi and onSEMI are trademarks of Semiconductor Components Industries, LLC dba onsemi or its subsidiaries in the United States and/or other countries. onsemi reserves the right to make changes without further notice to any products herein. onsemi makes no warranty, representation or guarantee regarding the suitability of its products for any particular purpose, nor does onsemi assume any liability arising out of the application or use of any product or circuit, and specifically disclaims any and all liability, including without limitation special, consequential or incidental damages. onsemi does not convey any license under its patent rights nor the rights of others.

SOIC-16 9.90x3.90x1.37 1.27P
CASE 751B
ISSUE M

DATE 18 OCT 2024

**GENERIC
MARKING DIAGRAM***

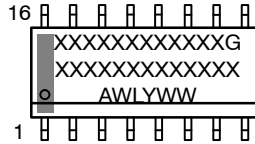

XXXXX = Specific Device Code
A = Assembly Location
WL = Wafer Lot
Y = Year
WW = Work Week
G = Pb-Free Package

*This information is generic. Please refer to device data sheet for actual part marking. Pb-Free indicator, "G" or microdot "•", may or may not be present. Some products may not follow the Generic Marking.

<p>STYLE 1:</p> <p>PIN 1. COLLECTOR 2. BASE 3. EMITTER 4. NO CONNECTION 5. EMITTER 6. BASE 7. COLLECTOR 8. COLLECTOR 9. BASE 10. EMITTER 11. NO CONNECTION 12. EMITTER 13. BASE 14. COLLECTOR 15. EMITTER 16. COLLECTOR</p>	<p>STYLE 2:</p> <p>PIN 1. CATHODE 2. ANODE 3. NO CONNECTION 4. CATHODE 5. CATHODE 6. NO CONNECTION 7. ANODE 8. CATHODE 9. CATHODE 10. ANODE 11. NO CONNECTION 12. CATHODE 13. CATHODE 14. NO CONNECTION 15. ANODE 16. CATHODE</p>	<p>STYLE 3:</p> <p>PIN 1. COLLECTOR, DYE #1 2. BASE, #1 3. EMITTER, #1 4. COLLECTOR, #1 5. COLLECTOR, #2 6. BASE, #2 7. EMITTER, #2 8. COLLECTOR, #2 9. COLLECTOR, #3 10. BASE, #3 11. EMITTER, #3 12. COLLECTOR, #3 13. COLLECTOR, #4 14. BASE, #4 15. EMITTER, #4 16. COLLECTOR, #4</p>	<p>STYLE 4:</p> <p>PIN 1. COLLECTOR, DYE #1 2. COLLECTOR, #1 3. COLLECTOR, #2 4. COLLECTOR, #2 5. COLLECTOR, #3 6. COLLECTOR, #3 7. COLLECTOR, #4 8. COLLECTOR, #4 9. BASE, #4 10. EMITTER, #4 11. BASE, #3 12. EMITTER, #3 13. BASE, #2 14. EMITTER, #2 15. BASE, #1 16. EMITTER, #1</p>
<p>STYLE 5:</p> <p>PIN 1. DRAIN, DYE #1 2. DRAIN, #1 3. DRAIN, #2 4. DRAIN, #2 5. DRAIN, #3 6. DRAIN, #3 7. DRAIN, #4 8. DRAIN, #4 9. GATE, #4 10. SOURCE, #4 11. GATE, #3 12. SOURCE, #3 13. GATE, #2 14. SOURCE, #2 15. GATE, #1 16. SOURCE, #1</p>	<p>STYLE 6:</p> <p>PIN 1. CATHODE 2. CATHODE 3. CATHODE 4. CATHODE 5. CATHODE 6. CATHODE 7. CATHODE 8. CATHODE 9. ANODE 10. ANODE 11. ANODE 12. ANODE 13. ANODE 14. ANODE 15. ANODE 16. ANODE</p>	<p>STYLE 7:</p> <p>PIN 1. SOURCE N-CH 2. COMMON DRAIN (OUTPUT) 3. COMMON DRAIN (OUTPUT) 4. GATE P-CH 5. COMMON DRAIN (OUTPUT) 6. COMMON DRAIN (OUTPUT) 7. COMMON DRAIN (OUTPUT) 8. SOURCE P-CH 9. SOURCE P-CH 10. COMMON DRAIN (OUTPUT) 11. COMMON DRAIN (OUTPUT) 12. COMMON DRAIN (OUTPUT) 13. GATE N-CH 14. COMMON DRAIN (OUTPUT) 15. COMMON DRAIN (OUTPUT) 16. SOURCE N-CH</p>	

DOCUMENT NUMBER:	98ASB42566B	Electronic versions are uncontrolled except when accessed directly from the Document Repository. Printed versions are uncontrolled except when stamped "CONTROLLED COPY" in red.
DESCRIPTION:	SOIC-16 9.90X3.90X1.37 1.27P	PAGE 2 OF 2

onsemi and **ONSEMI** are trademarks of Semiconductor Components Industries, LLC dba **onsemi** or its subsidiaries in the United States and/or other countries. **onsemi** reserves the right to make changes without further notice to any products herein. **onsemi** makes no warranty, representation or guarantee regarding the suitability of its products for any particular purpose, nor does **onsemi** assume any liability arising out of the application or use of any product or circuit, and specifically disclaims any and all liability, including without limitation special, consequential or incidental damages. **onsemi** does not convey any license under its patent rights nor the rights of others.

onsemi, **Onsemi**, and other names, marks, and brands are registered and/or common law trademarks of Semiconductor Components Industries, LLC dba "**onsemi**" or its affiliates and/or subsidiaries in the United States and/or other countries. **onsemi** owns the rights to a number of patents, trademarks, copyrights, trade secrets, and other intellectual property. A listing of **onsemi**'s product/patent coverage may be accessed at www.onsemi.com/site/pdf/Patent-Marking.pdf. **onsemi** reserves the right to make changes at any time to any products or information herein, without notice. The information herein is provided "as-is" and **onsemi** makes no warranty, representation or guarantee regarding the accuracy of the information, product features, availability, functionality, or suitability of its products for any particular purpose, nor does **onsemi** assume any liability arising out of the application or use of any product or circuit, and specifically disclaims any and all liability, including without limitation special, consequential or incidental damages. Buyer is responsible for its products and applications using **onsemi** products, including compliance with all laws, regulations and safety requirements or standards, regardless of any support or applications information provided by **onsemi**. "Typical" parameters which may be provided in **onsemi** data sheets and/or specifications can and do vary in different applications and actual performance may vary over time. All operating parameters, including "Typicals" must be validated for each customer application by customer's technical experts. **onsemi** does not convey any license under any of its intellectual property rights nor the rights of others. **onsemi** products are not designed, intended, or authorized for use as a critical component in life support systems or any FDA Class 3 medical devices or medical devices with a same or similar classification in a foreign jurisdiction or any devices intended for implantation in the human body. Should Buyer purchase or use **onsemi** products for any such unintended or unauthorized application, Buyer shall indemnify and hold **onsemi** and its officers, employees, subsidiaries, affiliates, and distributors harmless against all claims, costs, damages, and expenses, and reasonable attorney fees arising out of, directly or indirectly, any claim of personal injury or death associated with such unintended or unauthorized use, even if such claim alleges that **onsemi** was negligent regarding the design or manufacture of the part. **onsemi** is an Equal Opportunity/Affirmative Action Employer. This literature is subject to all applicable copyright laws and is not for resale in any manner.

ADDITIONAL INFORMATION

TECHNICAL PUBLICATIONS:

Technical Library: www.onsemi.com/design/resources/technical-documentation
onsemi Website: www.onsemi.com

ONLINE SUPPORT: www.onsemi.com/support

For additional information, please contact your local Sales Representative at www.onsemi.com/support/sales