

USB Type-C Controller for Mobile Chargers and Power Adapters

FUSB3301

Description

The FUSB3301 is an autonomous Source only Type-C controller optimized for mobile chargers and power adapters. It broadcasts the available current of the charger over CC1/CC2 using the USB Type-C standard and prevents VBUS from being asserted until a valid connection has been verified. It can be used for up to 15 W charging using Type-C protocols. The FUSB3301 has very low standby power consumption and is packaged in a 0.5 mm pitch MLP to accommodate power adapter PCBs.

Features

- Fully Autonomous Type-C Controller
- Supports Type-C Version 1.2
- Fixed Source Mode
- Low Standby Power: $I_{CC} = 5 \mu A$ (Typical)
- VBUS Switch Control
- Advertises Three Standard Type-C VBUS Current Levels (900 mA, 1.5 A, 3.0 A)
- 2 kV HBM ESD Protection
- 10 Lead MLP Package
- V_{DD} Operating Range, 3.0 V – 5.5 V

Applications

- USB Type-C Power Ports
- Mobile Chargers
- Power Adapters
- AC-DC Adapters

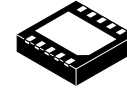

WDFN
10 LEAD
CASE 511DM

MARKING DIAGRAM



NZ = Specific Device Marking

PIN ASSIGNMENT

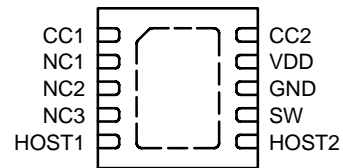

(Top View)

ORDERING INFORMATION

See detailed ordering and shipping information on page 2 of this data sheet.

FUSB3301

ORDERING INFORMATION

Part Number	Top Mark	Operating Temperature Range	Package	Packing Method
FUSB3301MPX	NZ	-40 to 85 °C	10-Lead, MLP, 3 mm x 3 mm	Tape and Reel

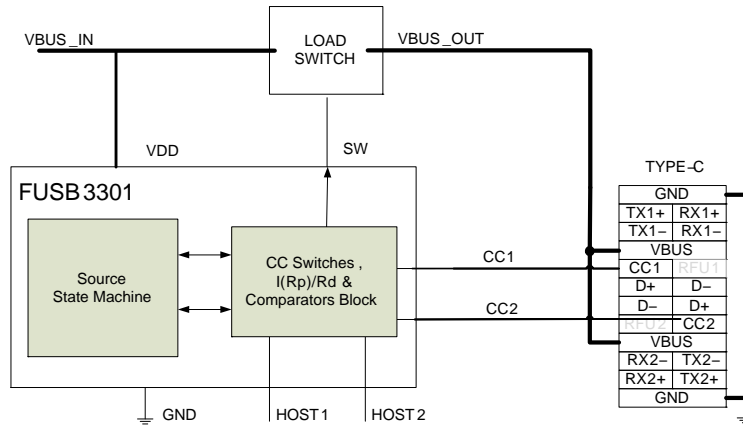

Figure 1. Block Diagram

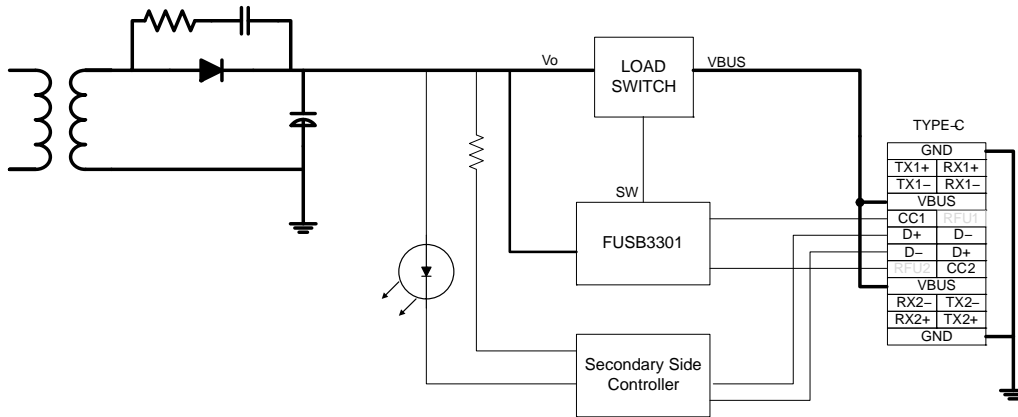

Figure 2. Typical Application

Table 1. PIN DESCRIPTIONS

Pin #	Name	Type	Description
1	CC1	Input/Output	Type-C Configuration Channel
2	NC1 (Note 1)	NC	No Connect
3	NC2 (Note 1)	NC	No Connect
4	NC3 (Note 1)	NC	No Connect
5	HOST1	Input	Host Current Select Pin with Internal Pull-up
6	HOST2	Input	Host Current Select Pin with Internal Pull-up
7	SW	Output	Open Drain output to control the VBUS load switch
8	GND	Power	Ground
9	VDD	Power	Power Supply
10	CC2	Input/Output	Type-C Configuration Channel

1. No connect pins can float or can be tied to ground.

FUSB3301

Table 2. CONNECTION STATE TABLE

CC1	CC2	SW	Description
NC	NC	HiZ	No Attach
Rd	NC	L	Attach to UFP (Sink)
NC	Rd	L	Attach to UFP (Sink)
Rd	Rd	HiZ	No Attach
Ra	NC	HiZ	No Attach
NC	Ra	HiZ	No Attach
Ra	Ra	HiZ	No Attach

Host Current

Table 3. HOST INPUT TRUTH TABLE

HOST2	HOST1	CC Current (μA)	Host Current (A)
GND / LOW	GND / LOW	330	3.0
GND / LOW	FLOAT / HIGH	180	1.5
FLOAT / HIGH	GND / LOW	180	1.5
FLOAT / HIGH	FLOAT / HIGH	80	0.9

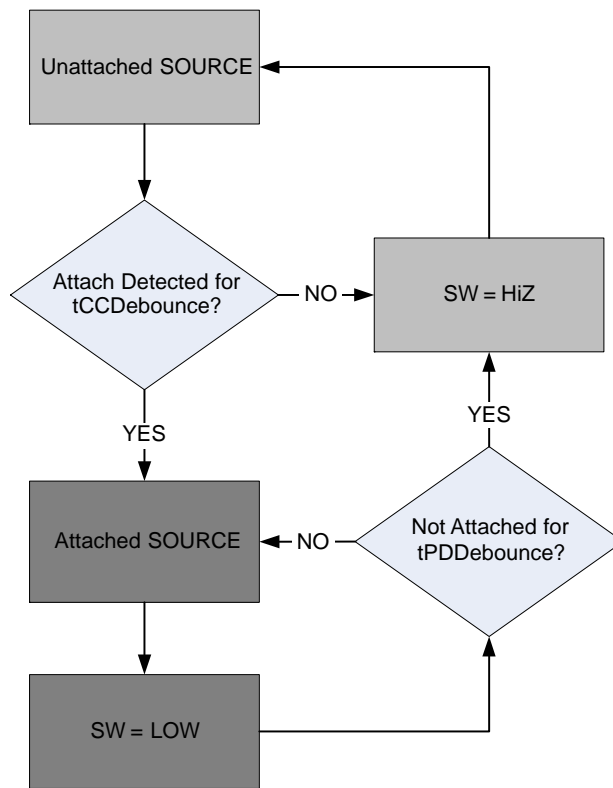

Figure 3. Source Attach Flowchart

FUSB3301

Table 4. ABSOLUTE MAXIMUM RATINGS

Symbol	Parameter		Min	Max	Unit	
V _{DD}	Supply Voltage		-0.5	6.0	V	
V _{CCX}	CC pins when configured as HOST		-0.5	6.0	V	
T _{STORAGE}	Storage Temperature Range		-65	+150	°C	
T _J	Maximum Junction Temperature			+150	°C	
T _L	Lead Temperature (Soldering, 10 seconds)			+260	°C	
ESD	IEC 61000-4-2 System ESD	Connector Pins (VBUS, CC1 & CC2)	Air Gap	15		kV
			Contact	8		
	Human Body Model, JEDEC JESD22-A114	Connector Pins (VBUS, CC1 and CC2)		4		kV
		Others		2		
	Charged Device Model, JEDEC JESD22-C101	All Pins	1		kV	

Stresses exceeding those listed in the Maximum Ratings table may damage the device. If any of these limits are exceeded, device functionality should not be assumed, damage may occur and reliability may be affected.

Table 5. RECOMMENDED OPERATING CONDITIONS

Symbol	Parameter	Min	Typ	Max	Unit
V _{DD}	Supply Voltage	3.0	5.0	5.5	V
T _A	Operating Ambient Temperature	-40		+85	°C
T _J	Operating Junction Temperature	-40		+125	°C

Functional operation above the stresses listed in the Recommended Operating Ranges is not implied. Extended exposure to stresses beyond the Recommended Operating Ranges limits may affect device reliability.

Table 6. DC AND TRANSIENT CHARACTERISTICS All typical values are at T_A = 25 °C unless otherwise specified.

Symbol	Parameter	T _A = -40 to +85 °C T _J = -40 to +125 °C			Unit
		Min	Typ	Max	
I _{80_CCX}	Source 80 μA CC Current (Default) HOST2 = VDD, HOST1 = VDD	64	80	96	μA
I _{180_CCX}	Source 180 μA CC Current (1.5 A) HOST2 = VDD, HOST1 = GND or HOST2 = GND, HOST1 = VDD	166	180	194	μA
I _{330_CCX}	Source 330 μA CC Current (3 A) HOST2 = GND, HOST1 = GND	304	330	356	μA
zOPEN	CC Resistance for Disabled State	126			kΩ
vRa-SRCdef	Ra Detection Threshold for CC Pin for Source for Default Current on VBUS	0.15	0.20	0.25	V
vRa-SRC1.5A	Ra Detection Threshold for CC pin for Source for 1.5 A Current on VBUS	0.35	0.40	0.45	V
vRa-SRC3A	Ra Detection Threshold for CC Pin for Source for 3 A Current on VBUS	0.75	0.80	0.85	V
vRd-SRCdef	Rd Detection Threshold for Source for Default Current (HOST2/1 = VDD/VDD)	1.50	1.60	1.65	V
vRd-SRC1.5A	Rd detection threshold for Source for 1.5 A Current (HOST2/1 = GND/VDD or VDD/GND)	1.50	1.60	1.65	V
vRd-SRC3A	Rd Detection Threshold for Source for 3 A Current (HOST2/1 = GND/GND)	2.45	2.60	2.75	V

Product parametric performance is indicated in the Electrical Characteristics for the listed test conditions, unless otherwise noted. Product performance may not be indicated by the Electrical Characteristics if operated under different conditions.

FUSB3301

Table 7. CURRENT CONSUMPTION

Symbol	Parameter	Conditions	V _{DD} (V)	T _A = -40 to +85 °C T _J = -40 to +125 °C			Unit
				Min	Typ	Max	
I _{stby}	Unattached Source	Nothing attached, Host Pins = VDD, GND, Float	3.0 to 5.5		5	20	μA
I _{attach}	Attach Current (Less Host Current)	Attached, Host Pins = VDD, GND, Float	3.0 to 5.5		10	15	μA

Table 8. TIMING PARAMETERS

Symbol	Parameter	T _A = -40 to +85 °C T _J = -40 to +125 °C			Unit
		Min	Typ	Max	
t _{CCDebounce}	Time from CC Voltage Detection until SW goes LOW	100	150	200	ms
t _{PDDebounce}	Time from CC Voltage Not Detected until SW goes to High-Z	10	15	20	ms

Table 9. IO SPECIFICATIONS

Symbol	Parameter	Conditions	V _{DD} (V)	T _A = -40 to +85 °C T _J = -40 to +125 °C			Unit
				Min	Typ	Max	
V _{OLSW}	SW Output Low Voltage	I _{OL} = 4 mA	3.0 to 5.5			0.4	V
V _{ILHOST}	HOST1/2 Low-Level Input Voltage		3.0 to 5.5			0.3 V _{DD}	V
V _{IHHOST}	HOST1/2 High-Level Input Voltage		3.0 to 5.5	0.7 V _{DD}			V

FUSB3301

REVISION HISTORY

Revision	Description of Changes	Date
3	Rebranded the document to onsemi format.	3/23/2026

This document has undergone updates prior to the inclusion of this revision history table. The changes tracked here only reflect updates made on the noted approval dates.

onsemi, **Onsemi**, and other names, marks, and brands are registered and/or common law trademarks of Semiconductor Components Industries, LLC dba "**onsemi**" or its affiliates and/or subsidiaries in the United States and/or other countries. **onsemi** owns the rights to a number of patents, trademarks, copyrights, trade secrets, and other intellectual property. A listing of **onsemi**'s product/patent coverage may be accessed at www.onsemi.com/site/pdf/Patent-Marking.pdf. **onsemi** reserves the right to make changes at any time to any products or information herein, without notice. The information herein is provided "as-is" and **onsemi** makes no warranty, representation or guarantee regarding the accuracy of the information, product features, availability, functionality, or suitability of its products for any particular purpose, nor does **onsemi** assume any liability arising out of the application or use of any product or circuit, and specifically disclaims any and all liability, including without limitation special, consequential or incidental damages. Buyer is responsible for its products and applications using **onsemi** products, including compliance with all laws, regulations and safety requirements or standards, regardless of any support or applications information provided by **onsemi**. "Typical" parameters which may be provided in **onsemi** data sheets and/or specifications can and do vary in different applications and actual performance may vary over time. All operating parameters, including "Typicals" must be validated for each customer application by customer's technical experts. **onsemi** does not convey any license under any of its intellectual property rights nor the rights of others. **onsemi** products are not designed, intended, or authorized for use as a critical component in life support systems or any FDA Class 3 medical devices or medical devices with a same or similar classification in a foreign jurisdiction or any devices intended for implantation in the human body. Should Buyer purchase or use **onsemi** products for any such unintended or unauthorized application, Buyer shall indemnify and hold **onsemi** and its officers, employees, subsidiaries, affiliates, and distributors harmless against all claims, costs, damages, and expenses, and reasonable attorney fees arising out of, directly or indirectly, any claim of personal injury or death associated with such unintended or unauthorized use, even if such claim alleges that **onsemi** was negligent regarding the design or manufacture of the part. **onsemi** is an Equal Opportunity/Affirmative Action Employer. This literature is subject to all applicable copyright laws and is not for resale in any manner.

ADDITIONAL INFORMATION

TECHNICAL PUBLICATIONS:

Technical Library: www.onsemi.com/design/resources/technical-documentation
onsemi Website: www.onsemi.com

ONLINE SUPPORT: www.onsemi.com/support

For additional information, please contact your local Sales Representative at www.onsemi.com/support/sales