

Mechanical Dimensions: Inches [mm]

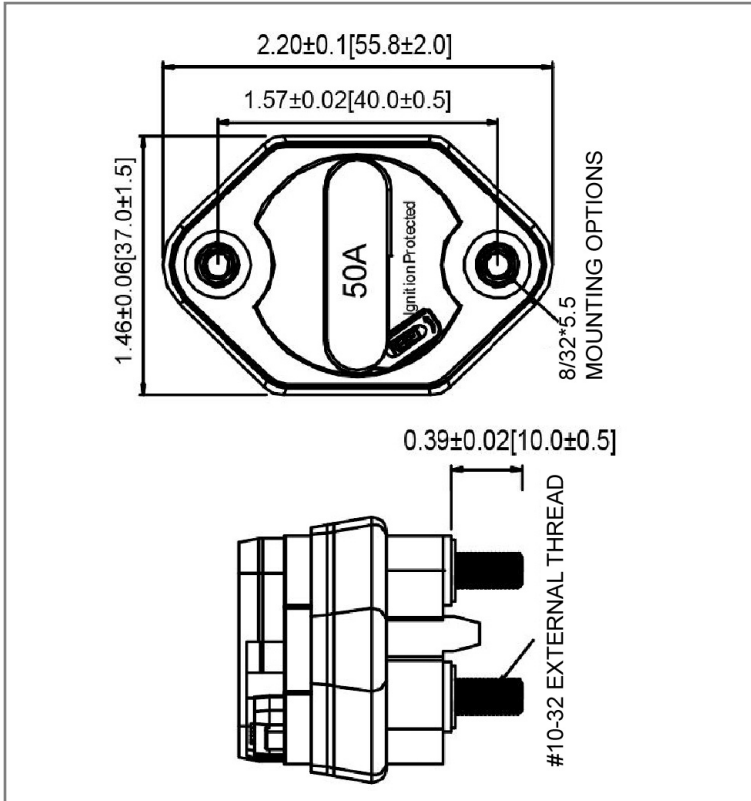

Part Numbers Information

Optifuse P/N	Current
642010	10A
642015	15A
642020	20A
642025	25A
642030	30A
642035	35A
642040	40A
642050	50A
642060	60A

Time vs. Percent of Rated Current

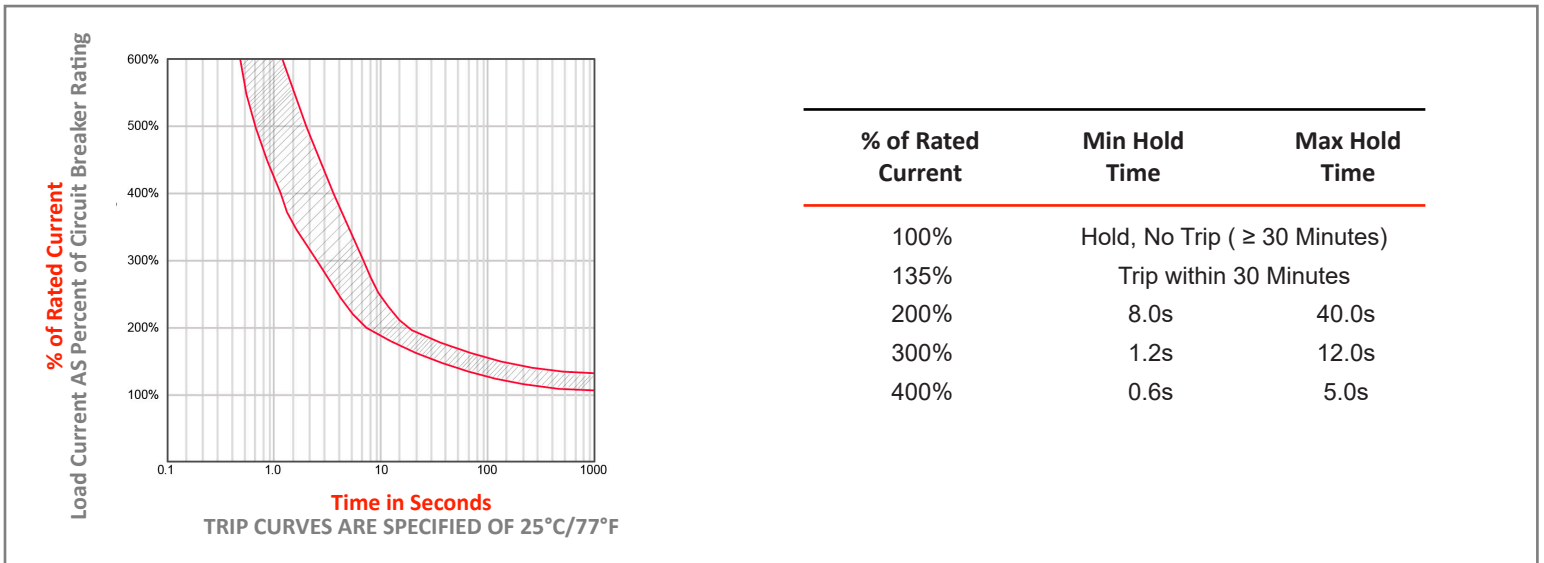

Electrical Specifications

Voltage Rating	32VDC
Reset Type	Type III - Manual Reset
Interrupting Rating	2500A @ 32VDC (ABYC E-11)
Operation Temperature	-40° F ~ 185° F
Testing	SAE J553, ABYC E-11

Material Specifications

Mid-Range - Waterproof Circuit Breaker	
Terminals Configuration	#10-32 Stud
Studs Torque	2.8 N.m max.
Mounting Torque	0.78 N.m max.
Mounting Type	Panel Mount; #8-32 threaded inserts
Ignition Protected	SAE J1171 Waterproof IP66

Mounting Hole

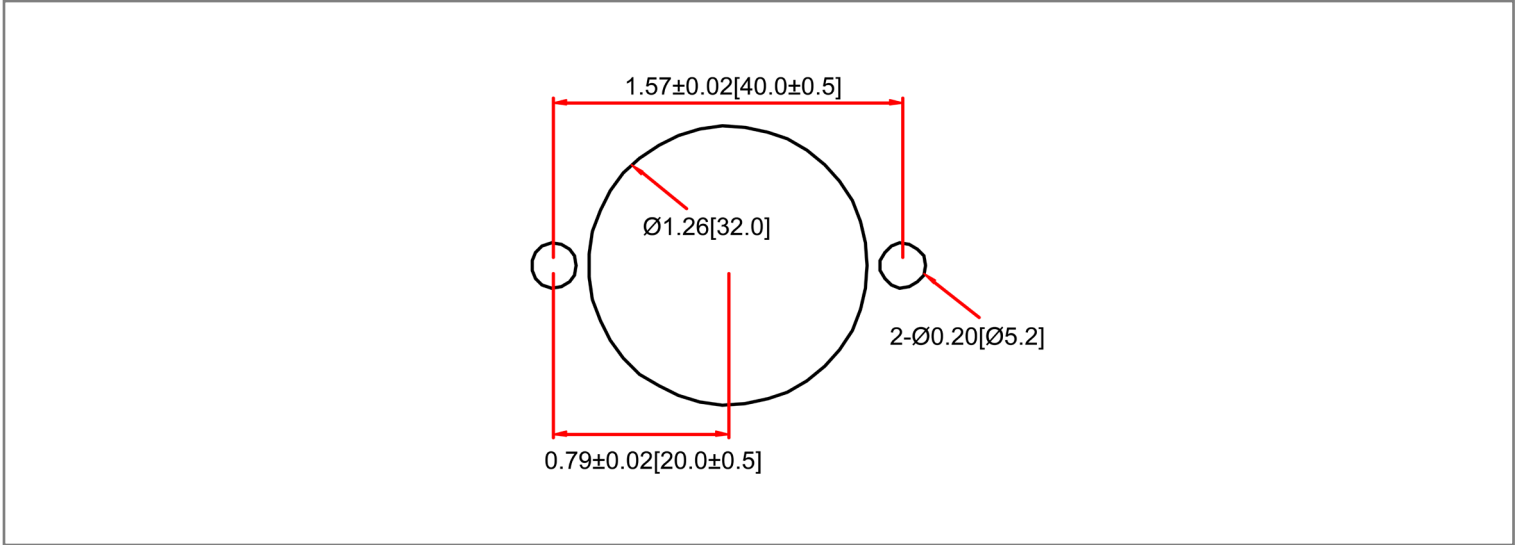

Temperature Derating Curve

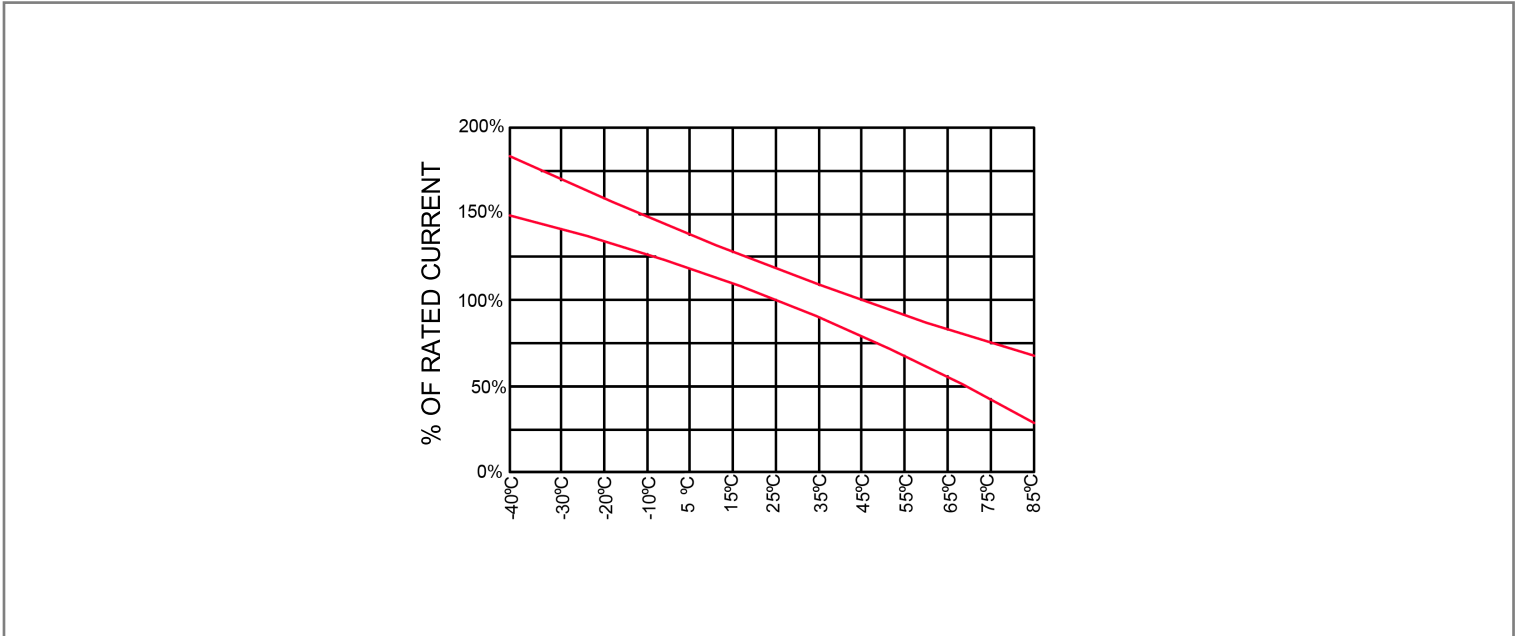

Disclaimer: Information provided is believed to be accurate and reliable. Users are responsible for confirming the suitability and performance of any OptiFuse product for their particular application. These products may not be appropriate for every use, and proper evaluation is recommended before implementation. For additional information, please visit optifuse.com/product-disclaimer.

Specifications are subject to change without notice

Rev	Date of issue	Revision Notes	Designed	Approved
E	03-03-2026	Include the trip time table	RC	OF