

Mechanical Dimensions: Inches [mm]

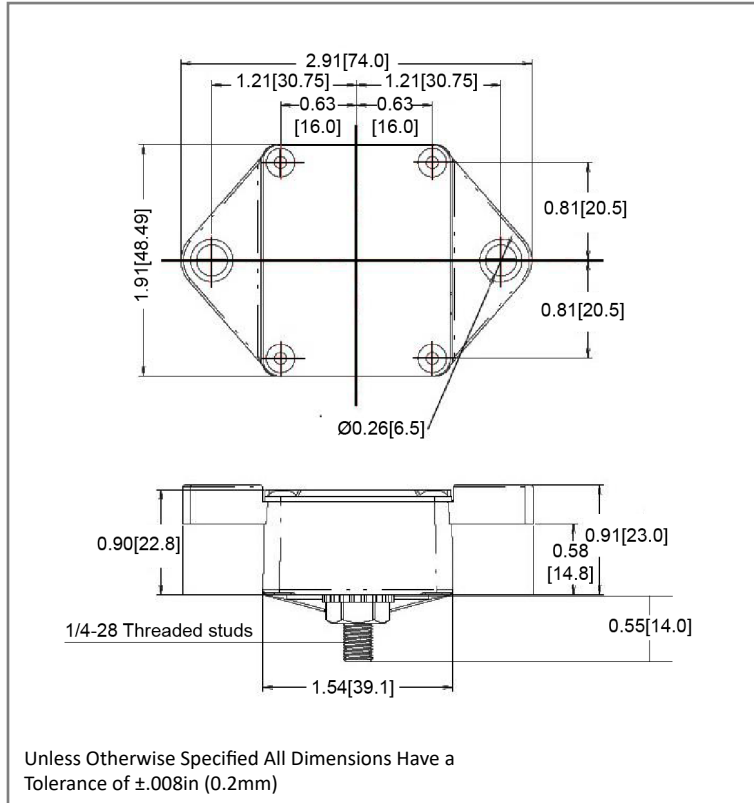

Part Numbers Information

Optifuse P/N	Current
141025	25A
141030	30A
141040	40A
141050	50A
141060	60A
141070	70A
141080	80A
141090	90A
141100	100A
141120	120A
141135	135A
141150	150A

Time vs. Percent of Rated Current

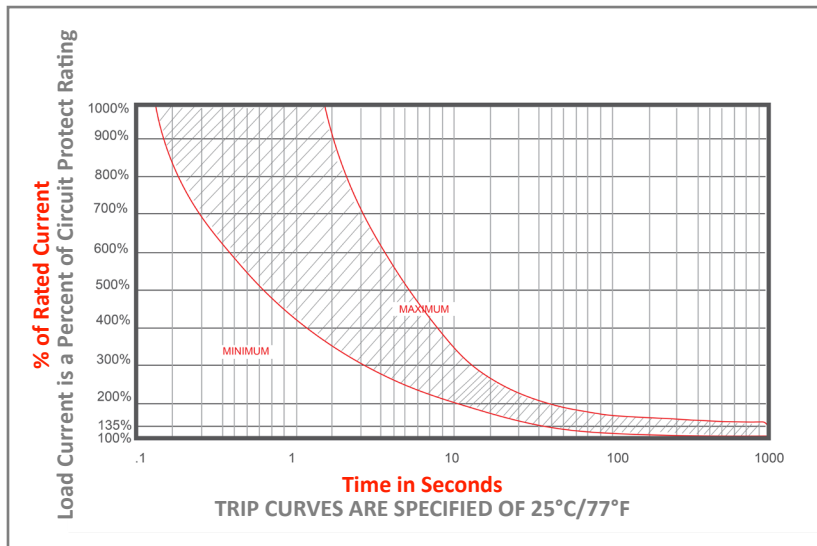

% of Rated Current	Min Hold Time	Max Hold Time
100%	No Trip (≥ 30 Minutes)	
135%	50s	30m
200%	12s	45s
300%	3.5s	15s

Trip time: Ambient temperature 25°C ± 3°C

Electrical Specifications

Voltage Rating	42VDC; 48VDC
Reset Type	Type I - Auto Reset
Interrupting Rating	3000A @ 30VDC (ABYC E-11); 1500A @ 48VDC; 3000A @ 44VDC
Operation Temperature	-25 °F ~ 180 °F -32 °C ~ 82 °C
Testing	SAE J553, IEC 60934

Material Specifications

Heavy Duty High Amp - Waterproof Circuit Breaker	
Body Material	Thermoset Plastic (UL94V-0)
Terminals Material	Nickel Plated
Terminals Configuration	1/4"-28 Stud
Studs Torque	10.3 N.m max.
Mounting Type	Panel Mount
Ignition Protected	SAE J1171
Ingress Protection	IP67

High Amperage Heavy Duty Circuit Breaker

141



Rev	Date of issue	Revision Notes	Designed	Approved
E	10-14-2025	Updated Voltage Rating, Updated Interrupting Rating	RC	OF