

Ultra-Low 0.35 Ω Dual SPDT Analog Switch NLAS5223B, NLAS5223BL



The NLAS5223B is an advanced CMOS analog switch fabricated in Sub-micron silicon gate CMOS technology. The device is a dual Independent Single Pole Double Throw (SPDT) switch featuring Ultra-Low R_{ON} of 0.35 Ω , at $V_{CC} = 4.3$ V.

The part also features guaranteed Break Before Make (BBM) switching, assuring the switches never short the driver.

Features

- Ultra-Low R_{ON} , 0.35 Ω (typ) at $V_{CC} = 4.3$ V
- NLAS5223B Interfaces with 2.8 V Chipset
- NLAS5223BL Interfaces with 1.8 V Chipset
- Single Supply Operation from 1.65–4.5 V
- Full 0– V_{CC} Signal Handling Capability
- High Off-Channel Isolation
- Low Standby Current, < 50 nA
- Low Distortion
- R_{ON} Flatness of 0.15 Ω
- High Continuous Current Capability
 - ◆ ± 320 mA Through Each Switch
- Large Current Clamping Diodes at Analog Inputs
 - ◆ ± 100 mA Continuous Current Capability
- Package:
 - ◆ 1.4 x 1.8 x 0.75 mm WQFN10 Pb-Free
 - ◆ 1.4 x 1.8 x 0.55 mm UQFN10 Pb-Free
- These are Pb-Free Devices

Applications

- Cell Phone Audio Block
- Speaker and Earphone Switching
- Ring-Tone Chip/Amplifier Switching
- Modems

MARKING DIAGRAM



XX = Specific Device Code
 AD = NLAS5223BMNR2G
 AE = NLAS5223BLMNR2G
 AP = NLAS5223BMUR2G
 \bar{M} = Date Code/Assembly Location
 ■ = Pb-Free Device

(Note: Microdot may be in either location)

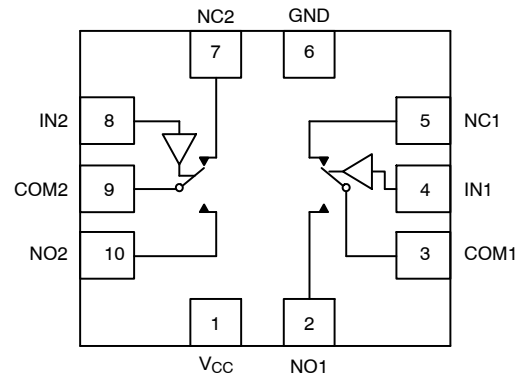

FUNCTION TABLE

IN 1, 2	NO 1, 2	NC 1, 2
0	OFF	ON
1	ON	OFF

ORDERING INFORMATION

See detailed ordering and shipping information in the package dimensions section on page 9 of this data sheet.

NOTE: Some of the devices on this data sheet have been **DISCONTINUED**. Please refer to the table on page 9.

NLAS5223B, NLAS5223BL

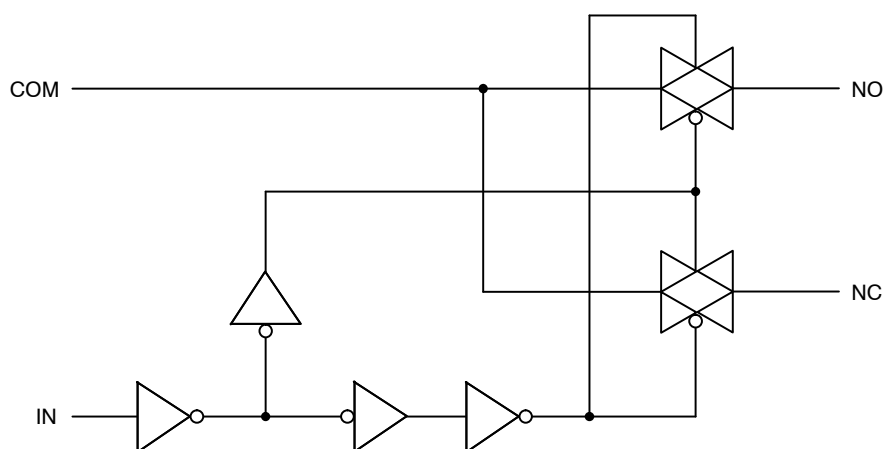

Figure 1. Logic Equivalent Circuit

PIN DESCRIPTION

QFN PIN #	Symbol	Name and Function
2, 5, 7, 10	NC1 to NC2, NO1 to NO2	Independent Channels
4, 8	IN1 and IN2	Controls
3, 9	COM1 and COM2	Common Channels
6	GND	Ground (V)
1	V _{CC}	Positive Supply Voltage

MAXIMUM RATINGS

Symbol	Parameter	Value	Unit
V _{CC}	Positive DC Supply Voltage	-0.5 to +5.5	V
V _{IS}	Analog Input Voltage (V _{NO} , V _{NC} , or V _{COM})	-0.5 ≤ V _{IS} ≤ V _{CC} + 0.5	V
V _{IN}	Digital Select Input Voltage	-0.5 ≤ V _{IN} ≤ +5.5	V
I _{anl1}	Continuous DC Current from COM to NC/NO	±320	mA
I _{anl-pk1}	Peak Current from COM to NC/NO, 10% Duty Cycle, 100 ms = t _{ON} (Note 1)	±600	mA
I _{anl-pk2}	Instantaneous Peak Current from COM to NC/NO, 10% Duty Cycle, t _{ON} < 1 μs	±850	mA
I _{clmp}	Continuous DC Current into COM/NO/NC with Respect to V _{CC} or GND	±100	mA

Stresses exceeding those listed in the Maximum Ratings table may damage the device. If any of these limits are exceeded, device functionality should not be assumed, damage may occur and reliability may be affected.

1. Defined as 10% ON, 90% OFF Duty Cycle.

RECOMMENDED OPERATING CONDITIONS

Symbol	Parameter	Min	Max	Unit
V _{CC}	DC Supply Voltage	1.65	4.5	V
V _{IN}	Digital Select Input Voltage (OVT) Overvoltage Tolerance	GND	4.5	V
V _{IS}	Analog Input Voltage (NC, NO, COM)	GND	V _{CC}	V
T _A	Operating Temperature Range	-40	+85	°C
t _r , t _f	Input Rise or Fall Time, SELECT V _{CC} = 1.6 V - 2.7 V V _{CC} = 3.0 V - 4.5 V		20 10	ns/V

Functional operation above the stresses listed in the Recommended Operating Ranges is not implied. Extended exposure to stresses beyond the Recommended Operating Ranges limits may affect device reliability.

NLAS5223B, NLAS5223BL

NLAS5223B DC CHARACTERISTICS – DIGITAL SECTION (Voltages Referenced to GND)

Symbol	Parameter	Condition	V _{CC}	Guaranteed Limit		Unit
				25°C	-40°C to +85°C	
V _{IH}	Minimum High-Level Input Voltage, Select Inputs		3.0	1.4	1.4	V
			4.3	2.0	2.0	
V _{IL}	Maximum Low-Level Input Voltage, Select Inputs		3.0	0.7	0.7	V
			4.3	0.8	0.8	
I _{IN}	Maximum Input Leakage Current, Select Inputs	V _{IN} = V _{CC} or GND	4.3	±0.1	±1.0	µA
I _{OFF}	Power Off Leakage Current	V _{IN} = V _{CC} or GND	0	±0.5	±2.0	µA
I _{CC}	Maximum Quiescent Supply Current (Note 2)	Select and V _{IS} = V _{CC} or GND	1.65 to 4.5	±1.0	±2.0	µA

Product parametric performance is indicated in the Electrical Characteristics for the listed test conditions, unless otherwise noted. Product performance may not be indicated by the Electrical Characteristics if operated under different conditions.

2. Guaranteed by design. Resistance measurements do not include test circuit or package resistance.

NLAS5223B DC ELECTRICAL CHARACTERISTICS – ANALOG SECTION

Symbol	Parameter	Condition	V _{CC}	Guaranteed Maximum Limit				Unit
				25°C		-40°C to +85°C		
				Min	Max	Min	Max	
R _{ON}	NC/NO On-Resistance (Note 3)	V _{IN} = V _{IL} or V _{IN} = V _{IH} V _{IS} = GND to V _{CC} I _{COM} = 100 mA	3.0		0.4		0.5	Ω
			4.3		0.35		0.4	
R _{FLAT}	NC/NO On-Resistance Flatness (Notes 3 and 4)	I _{COM} = 100 mA V _{IS} = 0 to V _{CC}	3.0		0.16		0.20	Ω
			4.3		0.11		0.14	
ΔR _{ON}	On-Resistance Match Between Channels (Notes 3 and 5)	V _{IS} = 1.5 V; I _{COM} = 100 mA V _{IS} = 2.2 V; I _{COM} = 100 mA	3.0		0.05		0.05	Ω
			4.3		0.05		0.05	
I _{NC(OFF)} I _{NO(OFF)}	NC or NO Off Leakage Current (Note 3)	V _{IN} = V _{IL} or V _{IH} V _{NO} or V _{NC} = 0.3 V V _{COM} = 4.0 V	4.3	-5.0	5.0	-50	50	nA
I _{COM(ON)}	COM ON Leakage Current (Note 3)	V _{IN} = V _{IL} or V _{IH} V _{NO} 0.3 V or 4.0 V with V _{NC} floating or V _{NC} 0.3 V or 4.0 V with V _{NO} floating V _{COM} = 0.3 V or 4.0 V	4.3	-10	10	-100	100	nA

Product parametric performance is indicated in the Electrical Characteristics for the listed test conditions, unless otherwise noted. Product performance may not be indicated by the Electrical Characteristics if operated under different conditions.

3. Guaranteed by design. Resistance measurements do not include test circuit or package resistance.

4. Flatness is defined as the difference between the maximum and minimum value of On-resistance as measured over the specified analog signal ranges.

5. ΔR_{ON} = R_{ON(MAX)} – R_{ON(MIN)} between NC1 and NC2 or between NO1 and NO2.

NLAS5223B, NLAS5223BL

NLAS5223BL DC CHARACTERISTICS – DIGITAL SECTION (Voltages Referenced to GND)

Symbol	Parameter	Condition	V _{CC}	Guaranteed Limit		Unit
				25°C	-40°C to +85°C	
V _{IH}	Minimum High-Level Input Voltage, Select Inputs		3.0	1.3	1.3	V
			4.3	1.6	1.6	
V _{IL}	Maximum Low-Level Input Voltage, Select Inputs		3.0	0.5	0.5	V
			4.3	0.6	0.6	
I _{IN}	Maximum Input Leakage Current, Select Inputs	V _{IN} = 4.5 V or GND	4.3	±0.1	±1.0	µA
I _{OFF}	Power Off Leakage Current	V _{IN} = 4.5 V or GND	0	±0.5	±2.0	µA
I _{CC}	Maximum Quiescent Supply Current (Note 6)	Select and V _{IS} = V _{CC} or GND	1.65 to 4.5	±1.0	±2.0	µA

Product parametric performance is indicated in the Electrical Characteristics for the listed test conditions, unless otherwise noted. Product performance may not be indicated by the Electrical Characteristics if operated under different conditions.

6. Guaranteed by design. Resistance measurements do not include test circuit or package resistance.

NLAS5223BL DC ELECTRICAL CHARACTERISTICS – ANALOG SECTION

Symbol	Parameter	Condition	V _{CC}	Guaranteed Maximum Limit				Unit
				25°C		-40°C to +85°C		
				Min	Max	Min	Max	
R _{ON}	NC/NO On-Resistance (Note 7)	V _{IN} = V _{IL} or V _{IN} = V _{IH} V _{IS} = GND to V _{CC} I _{COM} = 100 mA	3.0		0.4		0.5	Ω
			4.3		0.35		0.4	
R _{FLAT}	NC/NO On-Resistance Flatness (Notes 7 and 8)	I _{COM} = 100 mA V _{IS} = 0 to V _{CC}	3.0		0.16		0.20	Ω
			4.3		0.11		0.14	
ΔR _{ON}	On-Resistance Match Between Channels (Notes 7 and 9)	V _{IS} = 1.5 V; I _{COM} = 100 mA V _{IS} = 2.2 V; I _{COM} = 100 mA	3.0		0.05		0.05	Ω
			4.3		0.05		0.05	
I _{NC(OFF)} I _{NO(OFF)}	NC or NO Off Leakage Current (Note 7)	V _{IN} = V _{IL} or V _{IH} V _{NO} or V _{NC} = 0.3 V V _{COM} = 4.0 V	4.3	-10	10	-100	100	nA
I _{COM(ON)}	COM ON Leakage Current (Note 7)	V _{IN} = V _{IL} or V _{IH} V _{NO} 0.3 V or 4.0 V with V _{NC} floating or V _{NC} 0.3 V or 4.0 V with V _{NO} floating V _{COM} = 0.3 V or 4.0 V	4.3	-10	10	-100	100	nA

Product parametric performance is indicated in the Electrical Characteristics for the listed test conditions, unless otherwise noted. Product performance may not be indicated by the Electrical Characteristics if operated under different conditions.

7. Guaranteed by design. Resistance measurements do not include test circuit or package resistance.

8. Flatness is defined as the difference between the maximum and minimum value of On-resistance as measured over the specified analog signal ranges.

9. ΔR_{ON} = R_{ON(MAX)} – R_{ON(MIN)} between NC1 and NC2 or between NO1 and NO2.

NLAS5223B, NLAS5223BL

AC ELECTRICAL CHARACTERISTICS (Input $t_r = t_f = 3.0$ ns)

Symbol	Parameter	Test Conditions	V_{CC} (V)	V_{IS} (V)	Guaranteed Maximum Limit					Unit
					25°C			-40°C to +85°C		
					Min	Typ*	Max	Min	Max	
t_{ON}	Turn-On Time	$R_L = 50 \Omega$, $C_L = 35$ pF (Figures 3 and 4)	2.3 – 4.5	1.5			50		60	ns
t_{OFF}	Turn-Off Time	$R_L = 50 \Omega$, $C_L = 35$ pF (Figures 3 and 4)	2.3 – 4.5	1.5			30		40	ns
t_{BBM}	Minimum Break-Before-Make Time	$V_{IS} = 3.0$ $R_L = 50 \Omega$, $C_L = 35$ pF (Figure 2)	3.0	1.5	2	15				ns

		Typical @ 25, $V_{CC} = 3.6$ V		
C_{IN}	Control Pin Input Capacitance	3.5		pF
$C_{NO/NC}$	NO, NC Port Capacitance	60		pF
C_{COM}	COM Port Capacitance When Switch is Enabled	200		pF

*Typical Characteristics are at 25°C.

ADDITIONAL APPLICATION CHARACTERISTICS (Voltages Referenced to GND Unless Noted)

Symbol	Parameter	Condition	V_{CC} (V)	25°C	Unit
				Typical	
BW	Maximum On-Channel -3 dB Bandwidth or Minimum Frequency Response	V_{IN} centered between V_{CC} and GND (Figure 5)	1.65 – 4.5	19	MHz
V_{ONL}	Maximum Feed-through On Loss	$V_{IN} = 0$ dBm @ 100 kHz to 50 MHz V_{IN} centered between V_{CC} and GND (Figure 5)	1.65 – 4.5	-0.06	dB
V_{ISO}	Off-Channel Isolation	$f = 100$ kHz; $V_{IS} = 1$ V RMS; $C_L = 5.0$ pF V_{IN} centered between V_{CC} and GND (Figure 5)	1.65 – 4.5	-68	dB
Q	Charge Injection Select Input to Common I/O	$V_{IN} = V_{CC}$ to GND, $R_{IS} = 0 \Omega$, $C_L = 1.0$ nF $Q = C_L \times DV_{OUT}$ (Figure 6)	1.65 – 4.5	38	pC
THD	Total Harmonic Distortion THD + Noise	$F_{IS} = 20$ Hz to 20 kHz, $R_L = R_{gen} = 600 \Omega$, $C_L = 50$ pF $V_{IS} = 2.0$ V RMS	3.0	0.08	%
VCT	Channel-to-Channel Crosstalk	$f = 100$ kHz; $V_{IS} = 1.0$ V RMS, $C_L = 5.0$ pF, $R_L = 50 \Omega$ V_{IN} centered between V_{CC} and GND (Figure 5)	1.65 – 4.5	-70	dB

10. Off-Channel Isolation = $20 \log_{10} (V_{COM}/V_{NO})$, V_{COM} = output, V_{NO} = input to off switch.

NLAS5223B, NLAS5223BL

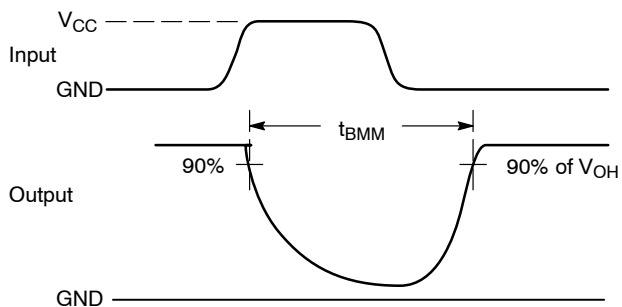
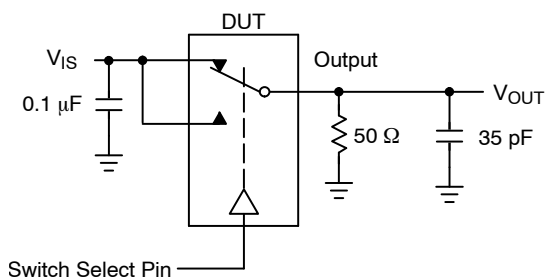

Figure 2. t_{BMM} (Time Break-Before-Make)

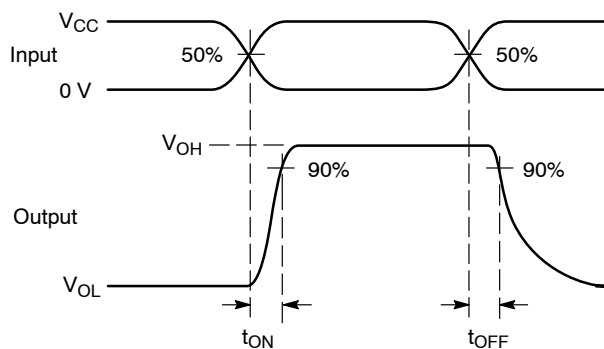
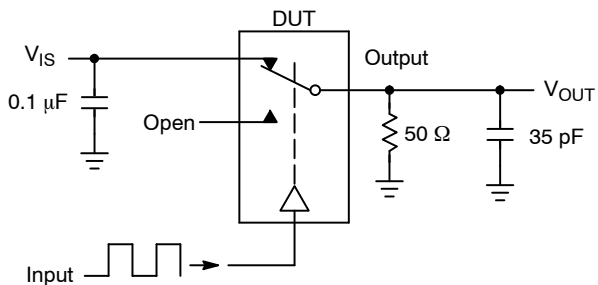

Figure 3. t_{ON}/t_{OFF}

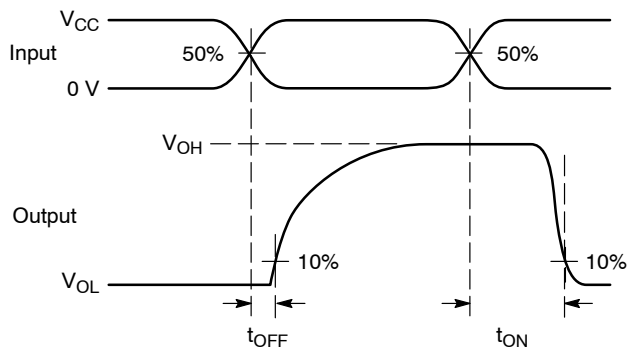
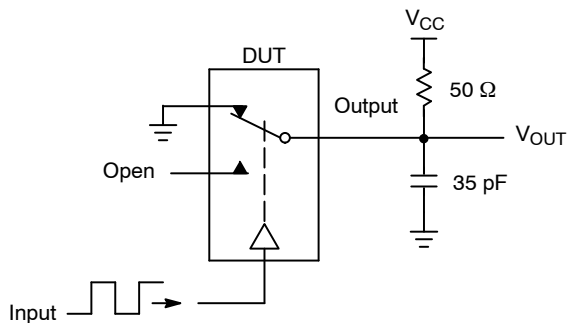
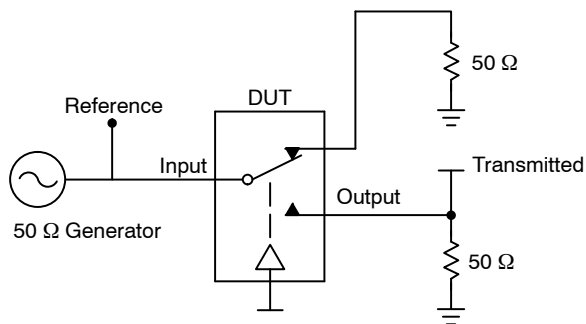

Figure 4. t_{ON}/t_{OFF}

NLAS5223B, NLAS5223BL



Channel switch control/s test socket is normalized. Off isolation is measured across an off channel. On loss is the bandwidth of an On switch. V_{ISO} , Bandwidth and V_{ONL} are independent of the input signal direction.

$$V_{ISO} = \text{Off Channel Isolation} = 20 \text{ Log} \left(\frac{V_{OUT}}{V_{IN}} \right) \text{ for } V_{IN} \text{ at } 100 \text{ kHz}$$

$$V_{ONL} = \text{On Channel Loss} = 20 \text{ Log} \left(\frac{V_{OUT}}{V_{IN}} \right) \text{ for } V_{IN} \text{ at } 100 \text{ kHz to } 50 \text{ MHz}$$

Bandwidth (BW) = the frequency 3 dB below V_{ONL}

V_{CT} = Use V_{ISO} setup and test to all other switch analog input/outputs terminated with 50 Ω

Figure 5. Off Channel Isolation/On Channel Loss (BW)/Crosstalk (On Channel to Off Channel)/ V_{ONL}

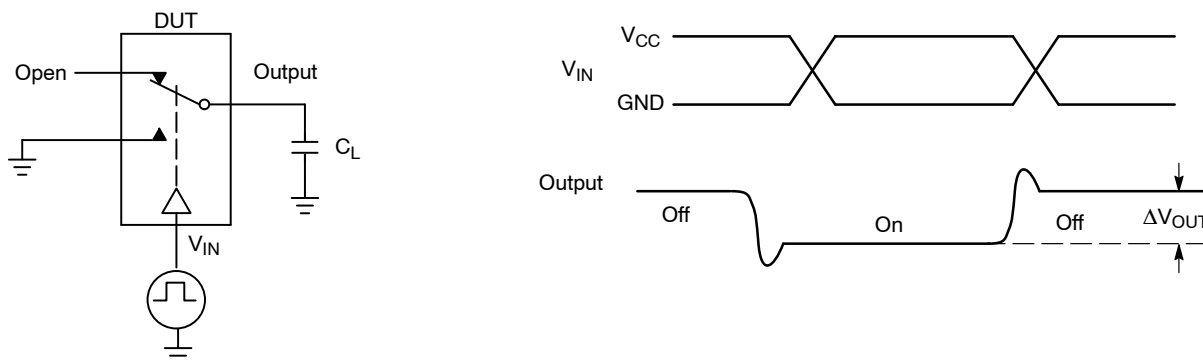

Figure 6. Charge Injection: (Q)

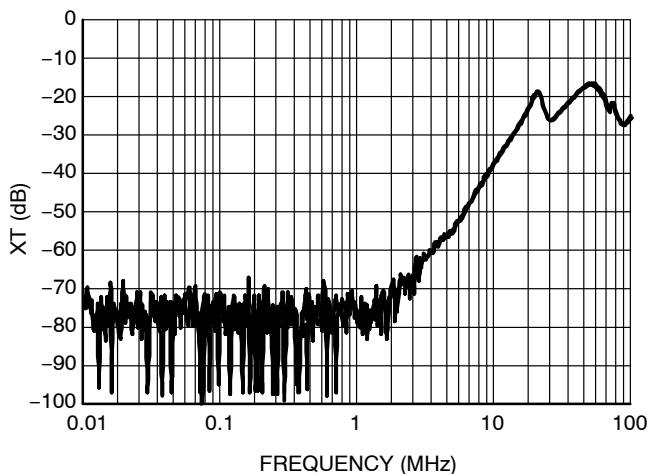

Figure 7. Cross Talk vs. Frequency @ $V_{CC} = 4.3\text{ V}$

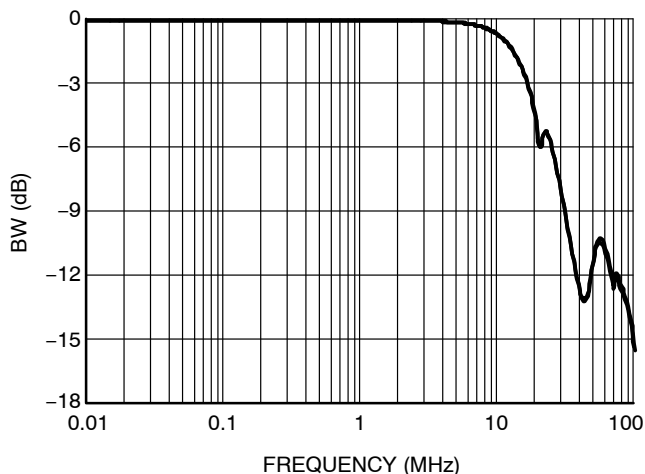

Figure 8. Bandwidth vs. Frequency

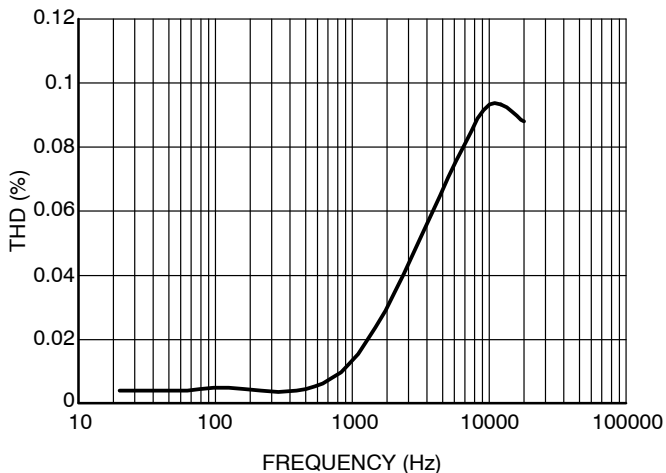

Figure 9. Total Harmonic Distortion

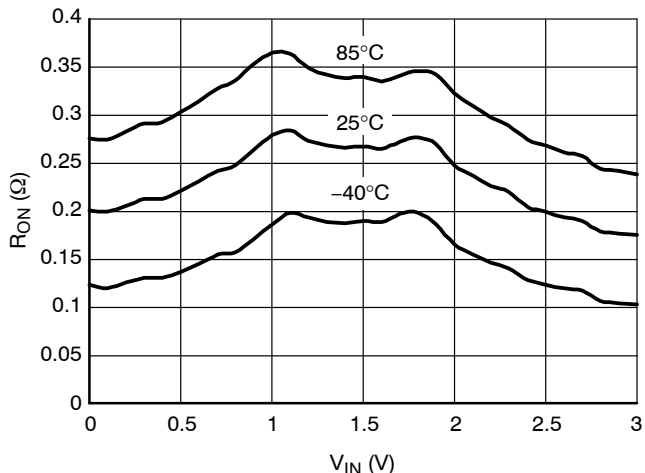

Figure 10. On-Resistance vs. Input Voltage @ $V_{CC} = 3.0\text{ V}$

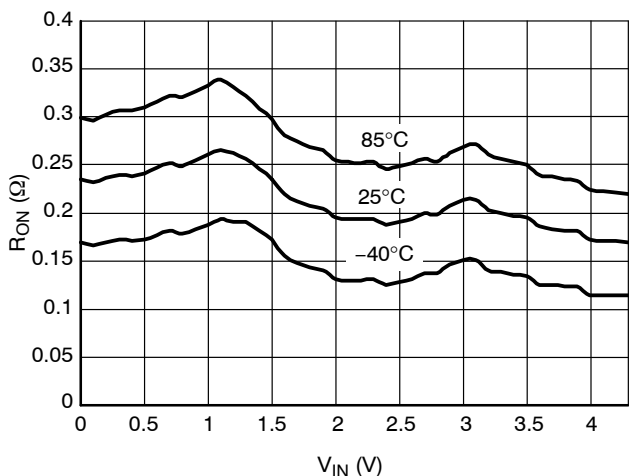

Figure 11. On-Resistance vs. Input Voltage @ $V_{CC} = 4.3\text{ V}$

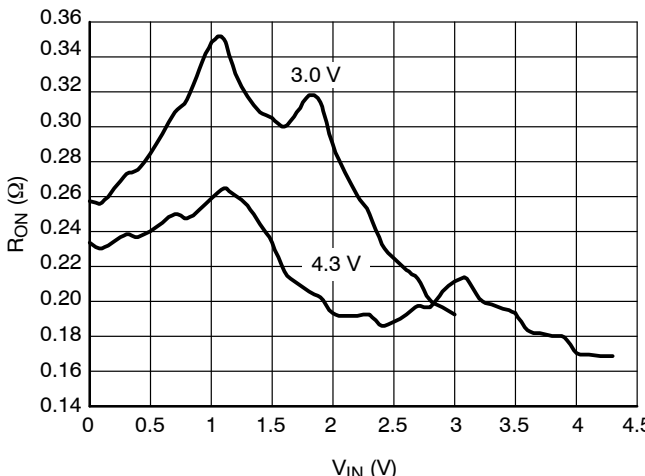

Figure 12. On-Resistance vs. Input Voltage

NLAS5223B, NLAS5223BL

ORDERING INFORMATION

Device	Package	Shipping†
NLAS5223BMNR2G	WQFN10 (Pb-Free)	3000 / Tape & Reel

DISCONTINUED (Note 11)

NLAS5223BLMNR2G	WQFN10 (Pb-Free)	3000 / Tape & Reel
NLAS5223BMUR2G	UQFN10 (Pb-Free)	3000 / Tape & Reel

†For information on tape and reel specifications, including part orientation and tape sizes, please refer to our Tape and Reel Packaging Specifications Brochure, [BRD8011/D](#).

11. **DISCONTINUED:** These devices are not recommended for new design. Please contact your **onsemi** representative for information. The most current information on these devices may be available on www.onsemi.com.

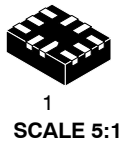

WQFN10, 1.4x1.8, 0.4P
CASE 488AQ
ISSUE C

DATE 19 JUN 2007

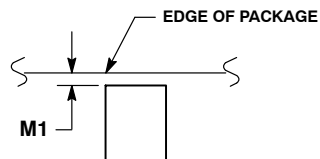
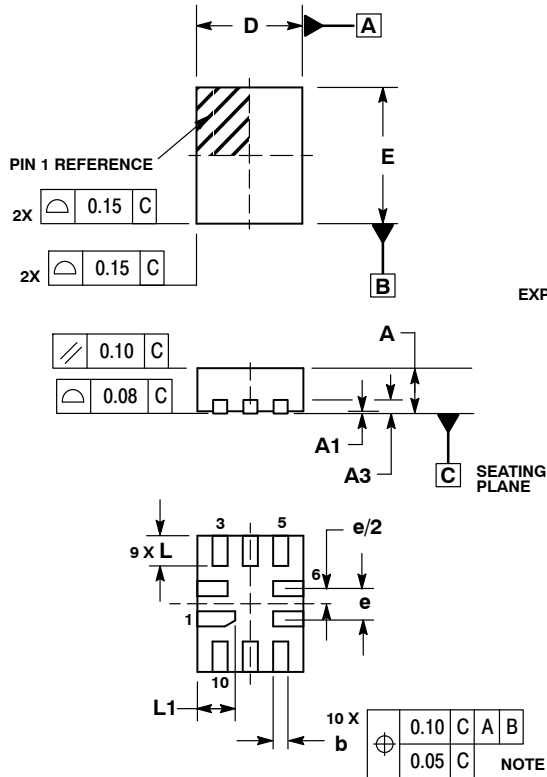

DETAIL A
Bottom View
(Optional)

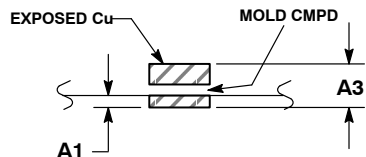

DETAIL B
Side View
(Optional)

- NOTES:
1. DIMENSIONING AND TOLERANCING PER ASME Y14.5M, 1994.
 2. CONTROLLING DIMENSION: MILLIMETERS
 3. DIMENSION b APPLIES TO PLATED TERMINAL AND IS MEASURED BETWEEN 0.25 AND 0.30 MM FROM TERMINAL.
 4. COPLANARITY APPLIES TO THE EXPOSED PAD AS WELL AS THE TERMINALS.
 5. EXPOSED PADS CONNECTED TO DIE FLAG. USED AS TEST CONTACTS.

MILLIMETERS		
DIM	MIN	MAX
A	0.70	0.80
A1	0.00	0.050
A3	0.20	REF
b	0.15	0.25
D	1.40	BSC
E	1.80	BSC
e	0.40	BSC
L	0.30	0.50
L1	0.40	0.60
M1	0.00	0.05

MOUNTING FOOTPRINT

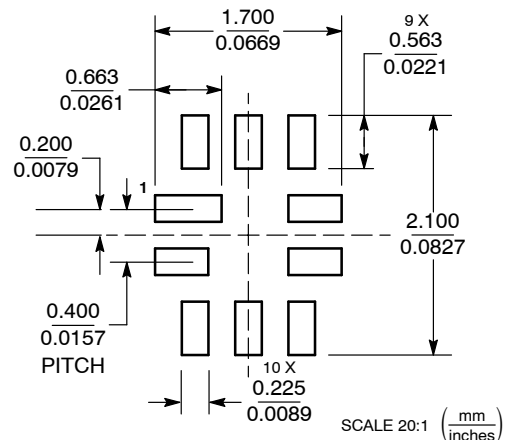

DOCUMENT NUMBER:	98AON20791D	Electronic versions are uncontrolled except when accessed directly from the Document Repository. Printed versions are uncontrolled except when stamped "CONTROLLED COPY" in red.
DESCRIPTION:	WQFN10, 1.4 X 1.8, 0.4P	PAGE 1 OF 1

onsemi and Onsemi are trademarks of Semiconductor Components Industries, LLC dba onsemi or its subsidiaries in the United States and/or other countries. onsemi reserves the right to make changes without further notice to any products herein. onsemi makes no warranty, representation or guarantee regarding the suitability of its products for any particular purpose, nor does onsemi assume any liability arising out of the application or use of any product or circuit, and specifically disclaims any and all liability, including without limitation special, consequential or incidental damages. onsemi does not convey any license under its patent rights nor the rights of others.

onsemi, **Onsemi**, and other names, marks, and brands are registered and/or common law trademarks of Semiconductor Components Industries, LLC dba "**onsemi**" or its affiliates and/or subsidiaries in the United States and/or other countries. **onsemi** owns the rights to a number of patents, trademarks, copyrights, trade secrets, and other intellectual property. A listing of **onsemi**'s product/patent coverage may be accessed at www.onsemi.com/site/pdf/Patent-Marking.pdf. **onsemi** reserves the right to make changes at any time to any products or information herein, without notice. The information herein is provided "as-is" and **onsemi** makes no warranty, representation or guarantee regarding the accuracy of the information, product features, availability, functionality, or suitability of its products for any particular purpose, nor does **onsemi** assume any liability arising out of the application or use of any product or circuit, and specifically disclaims any and all liability, including without limitation special, consequential or incidental damages. Buyer is responsible for its products and applications using **onsemi** products, including compliance with all laws, regulations and safety requirements or standards, regardless of any support or applications information provided by **onsemi**. "Typical" parameters which may be provided in **onsemi** data sheets and/or specifications can and do vary in different applications and actual performance may vary over time. All operating parameters, including "Typicals" must be validated for each customer application by customer's technical experts. **onsemi** does not convey any license under any of its intellectual property rights nor the rights of others. **onsemi** products are not designed, intended, or authorized for use as a critical component in life support systems or any FDA Class 3 medical devices or medical devices with a same or similar classification in a foreign jurisdiction or any devices intended for implantation in the human body. Should Buyer purchase or use **onsemi** products for any such unintended or unauthorized application, Buyer shall indemnify and hold **onsemi** and its officers, employees, subsidiaries, affiliates, and distributors harmless against all claims, costs, damages, and expenses, and reasonable attorney fees arising out of, directly or indirectly, any claim of personal injury or death associated with such unintended or unauthorized use, even if such claim alleges that **onsemi** was negligent regarding the design or manufacture of the part. **onsemi** is an Equal Opportunity/Affirmative Action Employer. This literature is subject to all applicable copyright laws and is not for resale in any manner.

ADDITIONAL INFORMATION

TECHNICAL PUBLICATIONS:

Technical Library: www.onsemi.com/design/resources/technical-documentation
onsemi Website: www.onsemi.com

ONLINE SUPPORT: www.onsemi.com/support

For additional information, please contact your local Sales Representative at www.onsemi.com/support/sales