

# Analog Multiplexer/ Demultiplexer

## High-Performance Silicon-Gate CMOS

### MC74LVXT8051

The MC74LVXT8051 utilizes silicon-gate CMOS technology to achieve fast propagation delays, low ON resistances, and low OFF leakage currents. This analog multiplexer/demultiplexer controls analog voltages that may vary across the complete power supply range (from  $V_{CC}$  to GND).

The LVXT8051 is similar in pinout to the high-speed HC4051A and the metal-gate MC14051B. The Channel-Select inputs determine which one of the Analog Inputs/Outputs is to be connected by means of an analog switch to the Common Output/Input. When the Enable pin is HIGH, all analog switches are turned off.

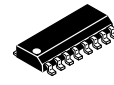
The Channel-Select and Enable inputs are compatible with TTL-type input thresholds. The input protection circuitry on this device allows overvoltage tolerance on the input, allowing the device to be used as a logic-level translator from 3.0 V CMOS logic to 5.0V CMOS Logic or from 1.8V CMOS logic to 3.0 V CMOS Logic while operating at the higher-voltage power supply.

The MC74LVXT8051 input structure provides protection when voltages up to 7.0 V are applied, regardless of the supply voltage. This allows the MC74LVXT8051 to be used to interface 5.0 V circuits to 3.0 V circuits.

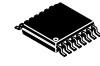
This device has been designed so that the ON resistance ( $R_{on}$ ) is more linear over input voltage than  $R_{on}$  of metal-gate CMOS analog switches.

#### Features

- Fast Switching and Propagation Speeds
- Low Crosstalk Between Switches
- Diode Protection on All Inputs/Outputs
- Analog Power Supply Range ( $V_{CC} - GND$ ) = 2.0 to 6.0 V
- Digital (Control) Power Supply Range ( $V_{CC} - GND$ ) = 2.0 to 6.0 V
- Improved Linearity and Lower ON Resistance Than Metal-Gate Counterparts
- Low Noise
- In Compliance With the Requirements of JEDEC Standard No. 7A
- These Devices are Pb-Free and are RoHS Compliant

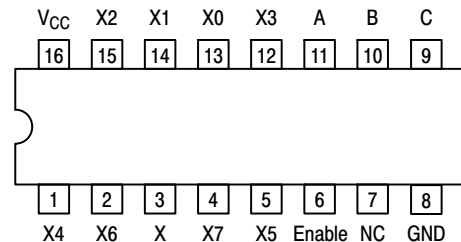


SOIC-16  
D SUFFIX  
CASE 751B

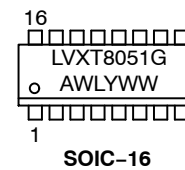


TSSOP-16  
DT SUFFIX  
CASE 948F

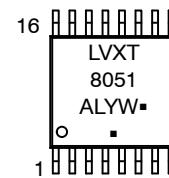
#### PIN ASSIGNMENT



#### MARKING DIAGRAMS



SOIC-16



TSSOP-16

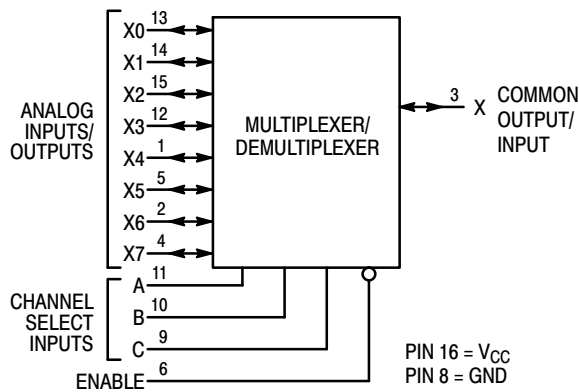
- LVXT8051 = Specific Device Code
- A = Assembly Location
- WL, L = Wafer Lot
- Y = Year
- WW, W = Work Week
- G or ■ = Pb-Free Package

(Note: Microdot may be in either location)

#### ORDERING INFORMATION

See detailed ordering and shipping information in the package dimensions section on page 10 of this data sheet.

# MC74LVXT8051



**Figure 1. LOGIC DIAGRAM**  
Single-Pole, 8-Position Plus Common Off

**FUNCTION TABLE – MC74LVXT8051**

Control Inputs				ON Channels
Enable	Select			
		C	B	A
L	L	L	L	X0
L	L	L	H	X1
L	L	H	L	X2
L	L	H	H	X3
L	H	L	L	X4
L	H	L	H	X5
L	H	H	L	X6
L	H	H	H	X7
H	X	X	X	NONE

X = Don't Care

## MAXIMUM RATINGS

Symbol	Parameter	Value	Unit
V <sub>CC</sub>	Positive DC Supply Voltage (Referenced to GND)	-0.5 to + 7.0	V
V <sub>IS</sub>	Analog Input Voltage	-0.5 to V <sub>CC</sub> + 0.5	V
V <sub>in</sub>	Digital Input Voltage (Referenced to GND)	-0.5 to V <sub>CC</sub> + 0.5	V
I	DC Current, Into or Out of Any Pin	-20	mA
P <sub>D</sub>	Power Dissipation in Still Air, SOIC Package† TSSOP Package†	500 450	mW
T <sub>stg</sub>	Storage Temperature Range	-65 to + 150	°C
T <sub>L</sub>	Lead Temperature, 1 mm from Case for 10 Seconds	260	°C

Stresses exceeding those listed in the Maximum Ratings table may damage the device. If any of these limits are exceeded, device functionality should not be assumed, damage may occur and reliability may be affected.

†Derating: SOIC Package: -7 mW/°C from 65° to 125°C  
TSSOP Package: -6.1 mW/°C from 65° to 125°C

This device contains protection circuitry to guard against damage due to high static voltages or electric fields. However, precautions must be taken to avoid applications of any voltage higher than maximum rated voltages to this high-impedance circuit. For proper operation, V<sub>in</sub> and V<sub>out</sub> should be constrained to the range GND ≤ (V<sub>in</sub> or V<sub>out</sub>) ≤ V<sub>CC</sub>. Unused inputs must always be tied to an appropriate logic voltage level (e.g., either GND or V<sub>CC</sub>). Unused outputs must be left open.

# MC74LVXT8051

## RECOMMENDED OPERATING CONDITIONS

Symbol	Parameter	Min	Max	Unit
V <sub>CC</sub>	Positive DC Supply Voltage (Referenced to GND)	2.0	6.0	V
V <sub>IS</sub>	Analog Input Voltage	0.0	V <sub>CC</sub>	V
V <sub>in</sub>	Digital Input Voltage (Referenced to GND)	GND	V <sub>CC</sub>	V
V <sub>IO*</sub>	Static or Dynamic Voltage Across Switch		1.2	V
T <sub>A</sub>	Operating Temperature Range, All Package Types	-55	+85	°C
t <sub>r</sub> , t <sub>f</sub>	Input Rise/Fall Time (Channel Select or Enable Inputs)	V <sub>CC</sub> = 3.3 V ± 0.3 V 0 V <sub>CC</sub> = 5.0 V ± 0.5 V 0	100 20	ns/V

Functional operation above the stresses listed in the Recommended Operating Ranges is not implied. Extended exposure to stresses beyond the Recommended Operating Ranges limits may affect device reliability.

\*For voltage drops across switch greater than 1.2 V (switch on), excessive V<sub>CC</sub> current may be drawn; i.e., the current out of the switch may contain both V<sub>CC</sub> and switch input components. The reliability of the device will be unaffected unless the Maximum Ratings are exceeded.

## DC CHARACTERISTICS – Digital Section (Voltages Referenced to GND)

Symbol	Parameter	Condition	V <sub>CC</sub> V	Guaranteed Limit			Unit
				-55 to 25°C	≤85°C	≤125°C	
V <sub>IH</sub>	Minimum High-Level Input Voltage, Channel-Select or Enable Inputs	R <sub>on</sub> = Per Spec	3.0	1.2	1.2	1.2	V
			4.5	2.0	2.0	2.0	
			5.5	2.0	2.0	2.0	
V <sub>IL</sub>	Maximum Low-Level Input Voltage, Channel-Select or Enable Inputs	R <sub>on</sub> = Per Spec	3.0	0.53	0.53	0.53	V
			4.5	0.8	0.8	0.8	
			5.5	0.8	0.8	0.8	
I <sub>in</sub>	Maximum Input Leakage Current, Channel-Select or Enable Inputs	V <sub>in</sub> = V <sub>CC</sub> or GND	5.5	±0.1	±1.0	±1.0	µA
I <sub>CC</sub>	Maximum Quiescent Supply Current (per Package)	Channel Select, Enable and V <sub>IS</sub> = V <sub>CC</sub> or GND; V <sub>IO</sub> = 0 V	5.5	4	40	160	µA

## DC ELECTRICAL CHARACTERISTICS Analog Section

Symbol	Parameter	Test Conditions	V <sub>CC</sub> V	Guaranteed Limit			Unit
				-55 to 25°C	≤85°C	≤125°C	
R <sub>on</sub>	Maximum "ON" Resistance	V <sub>in</sub> = V <sub>IL</sub> or V <sub>IH</sub> V <sub>IS</sub> = V <sub>CC</sub> to GND  I <sub>S</sub>   ≤ 10.0 mA (Figures 1, 2)	3.0	40	45	50	Ω
			4.5	30	32	37	
			5.5	25	28	30	
		V <sub>in</sub> = V <sub>IL</sub> or V <sub>IH</sub> V <sub>IS</sub> = V <sub>CC</sub> or GND (Endpoints)  I <sub>S</sub>   ≤ 10.0 mA (Figures 1, 2)	3.0	30	35	40	
			4.5	25	28	35	
			5.5	20	25	30	
ΔR <sub>on</sub>	Maximum Difference in "ON" Resistance Between Any Two Channels in the Same Package	V <sub>in</sub> = V <sub>IL</sub> or V <sub>IH</sub> V <sub>IS</sub> = 1/2 (V <sub>CC</sub> - GND)  I <sub>S</sub>   ≤ 10.0 mA	3.0	15	20	25	Ω
			4.5	8.0	12	15	
			5.5	8.0	12	15	
I <sub>off</sub>	Maximum Off-Channel Leakage Current, Any One Channel	V <sub>in</sub> = V <sub>IL</sub> or V <sub>IH</sub> ; V <sub>IO</sub> = V <sub>CC</sub> or GND; Switch Off (Figure 3)	5.5	0.1	0.5	1.0	µA
	Maximum Off-Channel Leakage Current, Common Channel	V <sub>in</sub> = V <sub>IL</sub> or V <sub>IH</sub> ; V <sub>IO</sub> = V <sub>CC</sub> or GND; Switch Off (Figure 4)	5.5	0.2	2.0	4.0	
I <sub>on</sub>	Maximum On-Channel Leakage Current, Channel-to-Channel	V <sub>in</sub> = V <sub>IL</sub> or V <sub>IH</sub> ; Switch-to-Switch = V <sub>CC</sub> or GND; (Figure 5)	5.5	0.2	2.0	4.0	µA

# MC74LVXT8051

## AC CHARACTERISTICS (C<sub>L</sub> = 50 pF, Input t<sub>r</sub> = t<sub>f</sub> = 3 ns)

Symbol	Parameter	V <sub>CC</sub> V	Guaranteed Limit			Unit
			-55 to 25°C	≤85°C	≤125°C	
t <sub>PLH</sub> , t <sub>PHL</sub>	Maximum Propagation Delay, Channel-Select to Analog Output (Figure 9)	2.0	30	35	40	ns
		3.0	20	25	30	
		4.5	15	18	22	
		5.5	15	18	20	
t <sub>PLH</sub> , t <sub>PHL</sub>	Maximum Propagation Delay, Analog Input to Analog Output (Figure 10)	2.0	4.0	6.0	8.0	ns
		3.0	3.0	5.0	6.0	
		4.5	1.0	2.0	2.0	
		5.5	1.0	2.0	2.0	
t <sub>PLZ</sub> , t <sub>PHZ</sub>	Maximum Propagation Delay, Enable to Analog Output (Figure 11)	2.0	30	35	40	ns
		3.0	20	25	30	
		4.5	15	18	22	
		5.5	15	18	20	
t <sub>PZL</sub> , t <sub>PZH</sub>	Maximum Propagation Delay, Enable to Analog Output (Figure 11)	2.0	20	25	30	ns
		3.0	12	14	15	
		4.5	8.0	10	12	
		5.5	8.0	10	12	
C <sub>in</sub>	Maximum Input Capacitance, Channel-Select or Enable Inputs		10	10	10	pF
C <sub>I/O</sub>	Maximum Capacitance Analog I/O (All Switches Off) Common O/I Feedthrough		35	35	35	pF
			130	130	130	
			1.0	1.0	1.0	

C <sub>PD</sub>	Power Dissipation Capacitance (Figure 13)*	Typical @ 25°C, V <sub>CC</sub> = 5.0 V			pF
		45			

\* Used to determine the no-load dynamic power consumption:  $P_D = C_{PD} V_{CC}^2 f + I_{CC} V_{CC}$ .

## ADDITIONAL APPLICATION CHARACTERISTICS (GND = 0 V)

Symbol	Parameter	Condition	V <sub>CC</sub> V	Limit*	Unit
				25°C	
BW	Maximum On-Channel Bandwidth or Minimum Frequency Response (Figure 6)	f <sub>in</sub> = 1MHz Sine Wave; Adjust f <sub>in</sub> Voltage to Obtain 0dBm at V <sub>OS</sub> ; Increase f <sub>in</sub> Frequency Until dB Meter Reads -3dB; R <sub>L</sub> = 50Ω, C <sub>L</sub> = 10pF	3.0	80	MHz
			4.5	80	
			5.5	80	
-	Off-Channel Feedthrough Isolation (Figure 7)	f <sub>in</sub> = Sine Wave; Adjust f <sub>in</sub> Voltage to Obtain 0dBm at V <sub>IS</sub> f <sub>in</sub> = 10kHz, R <sub>L</sub> = 600Ω, C <sub>L</sub> = 50pF	3.0	-50	dB
			4.5	-50	
			5.5	-50	
			3.0	-37	
			4.5	-37	
			5.5	-37	
-	Feedthrough Noise. Channel-Select Input to Common I/O (Figure 8)	V <sub>in</sub> ≤ 1MHz Square Wave (t <sub>r</sub> = t <sub>f</sub> = 3ns); Adjust R <sub>L</sub> at Setup so that I <sub>S</sub> = 0A; Enable = GND R <sub>L</sub> = 600Ω, C <sub>L</sub> = 50pF	3.0	25	mV <sub>PP</sub>
			4.5	105	
			5.5	135	
			3.0	35	
			4.5	145	
			5.5	190	
-	Crosstalk Between Any Two Switches (Figure 12)	f <sub>in</sub> = Sine Wave; Adjust f <sub>in</sub> Voltage to Obtain 0dBm at V <sub>IS</sub> f <sub>in</sub> = 10kHz, R <sub>L</sub> = 600Ω, C <sub>L</sub> = 50pF	3.0	-50	dB
			4.5	-50	
			5.5	-50	
			3.0	-60	
			4.5	-60	
			5.5	-60	
THD	Total Harmonic Distortion (Figure 14)	f <sub>in</sub> = 1kHz, R <sub>L</sub> = 10kΩ, C <sub>L</sub> = 50pF THD = THD <sub>measured</sub> - THD <sub>source</sub> V <sub>IS</sub> = 2.0V <sub>PP</sub> sine wave V <sub>IS</sub> = 4.0V <sub>PP</sub> sine wave V <sub>IS</sub> = 5.0V <sub>PP</sub> sine wave	3.0	0.10	%
			4.5	0.08	
			5.5	0.05	

\*Limits not tested. Determined by design and verified by qualification.

# MC74LVXT8051

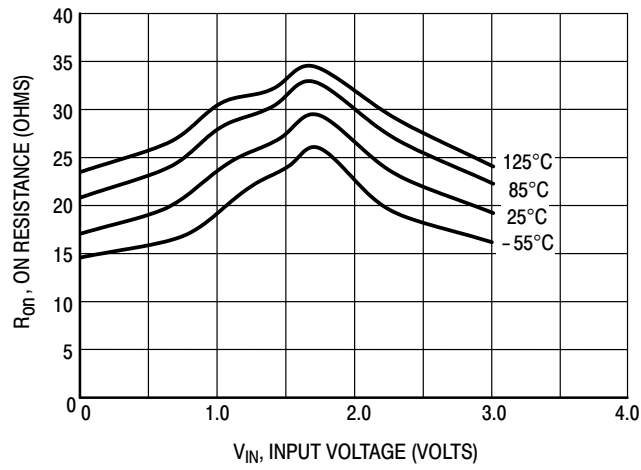


Figure 1a. Typical On Resistance,  $V_{CC} = 3.0$  V

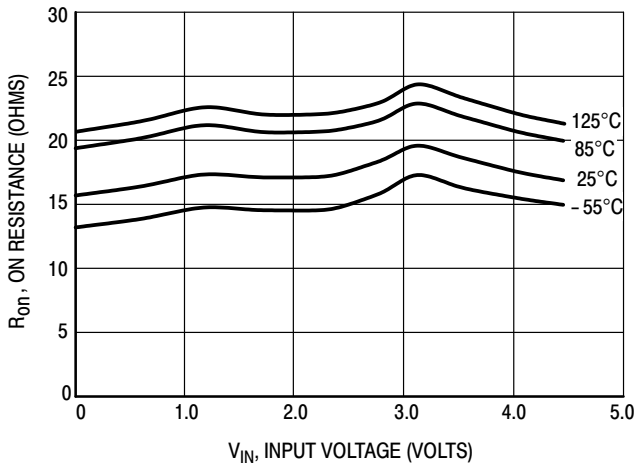


Figure 1b. Typical On Resistance,  $V_{CC} = 4.5$  V

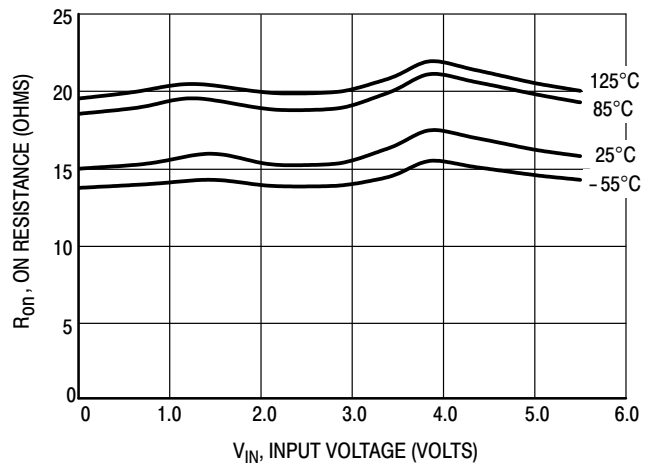


Figure 1c. Typical On Resistance,  $V_{CC} = 5.5$  V

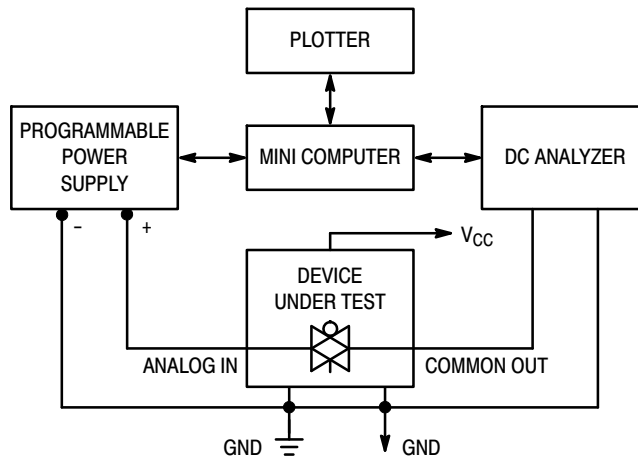


Figure 2. On Resistance Test Set-Up

# MC74LVXT8051

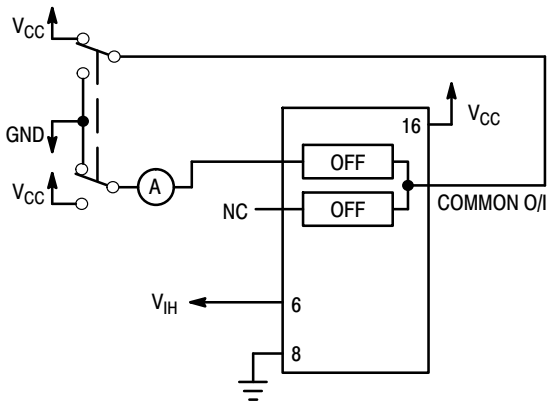


Figure 3. Maximum Off Channel Leakage Current, Any One Channel, Test Set-Up

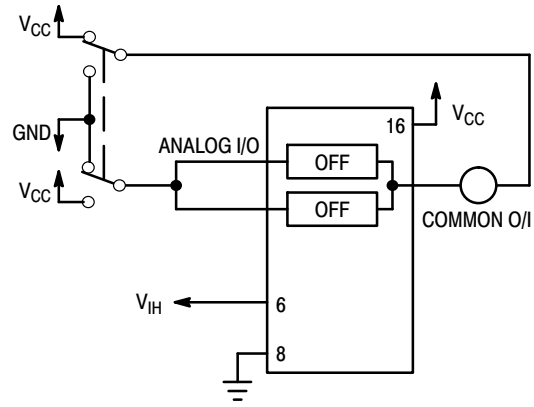


Figure 4. Maximum Off Channel Leakage Current, Common Channel, Test Set-Up

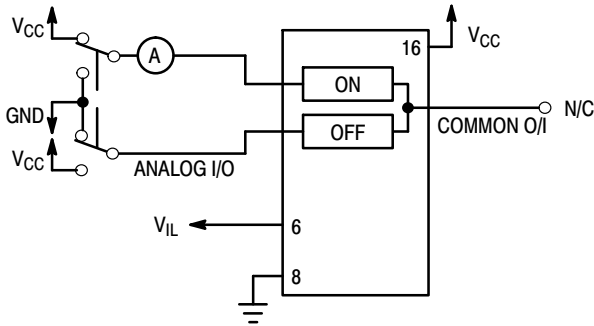
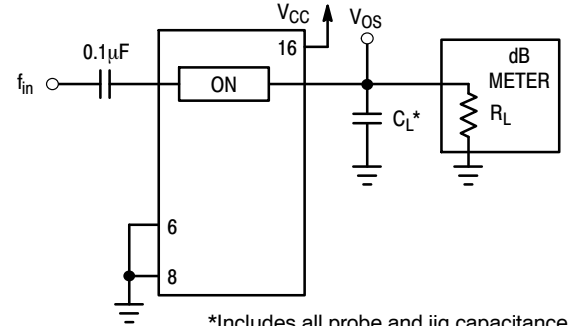
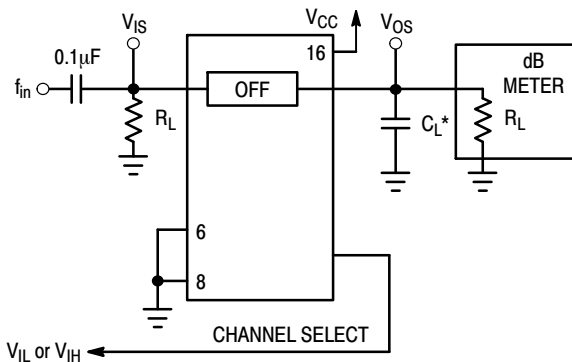


Figure 5. Maximum On Channel Leakage Current, Channel to Channel, Test Set-Up



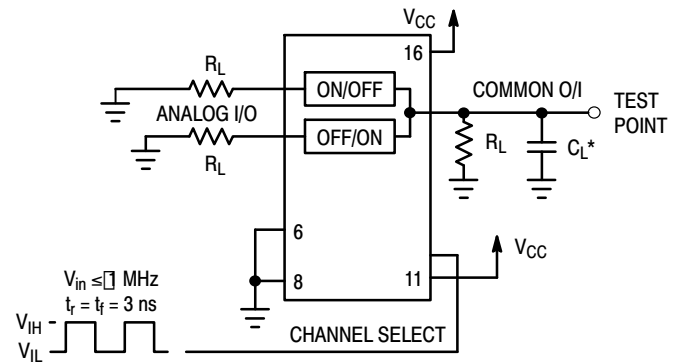
\*Includes all probe and jig capacitance

Figure 6. Maximum On Channel Bandwidth, Test Set-Up



\*Includes all probe and jig capacitance

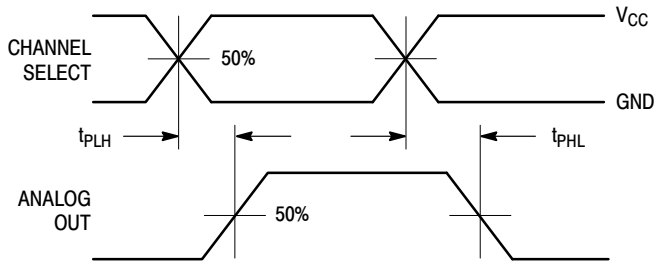
Figure 7. Off Channel Feedthrough Isolation, Test Set-Up



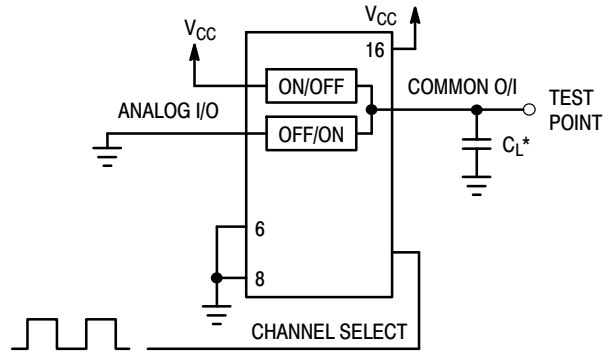
\*Includes all probe and jig capacitance

Figure 8. Feedthrough Noise, Channel Select to Common Out, Test Set-Up

# MC74LVXT8051

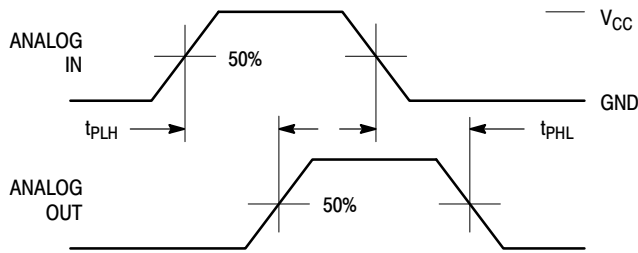


**Figure 9a. Propagation Delays, Channel Select to Analog Out**

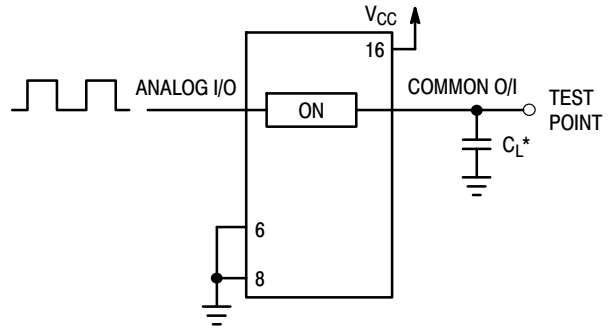


\*Includes all probe and jig capacitance

**Figure 9b. Propagation Delay, Test Set-Up Channel Select to Analog Out**

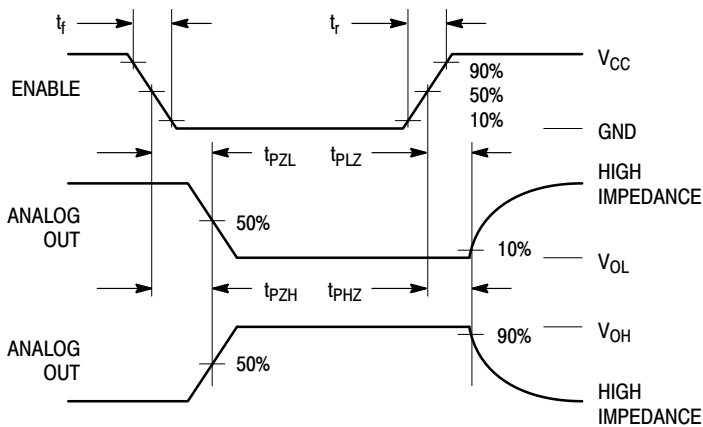


**Figure 10a. Propagation Delays, Analog In to Analog Out**

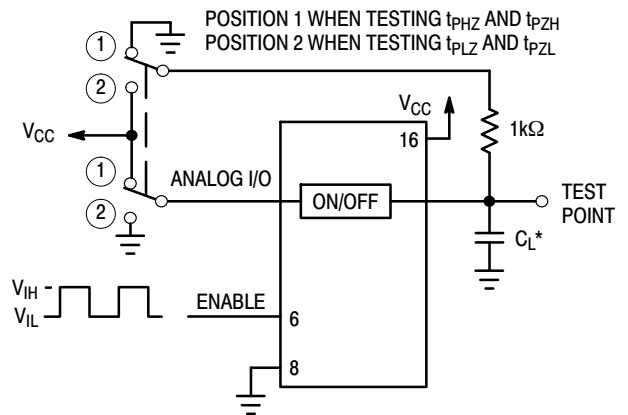


\*Includes all probe and jig capacitance

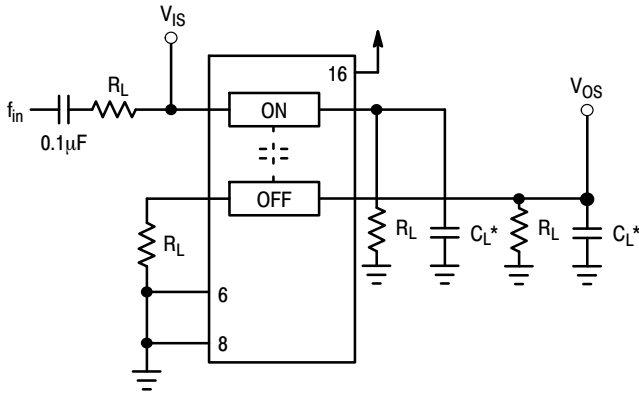
**Figure 10b. Propagation Delay, Test Set-Up Analog In to Analog Out**



**Figure 11a. Propagation Delays, Enable to Analog Out**



**Figure 11b. Propagation Delay, Test Set-Up Enable to Analog Out**



\*Includes all probe and jig capacitance

Figure 12. Crosstalk Between Any Two Switches, Test Set-Up

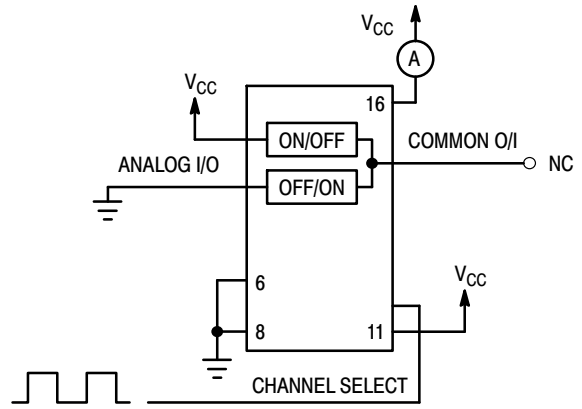
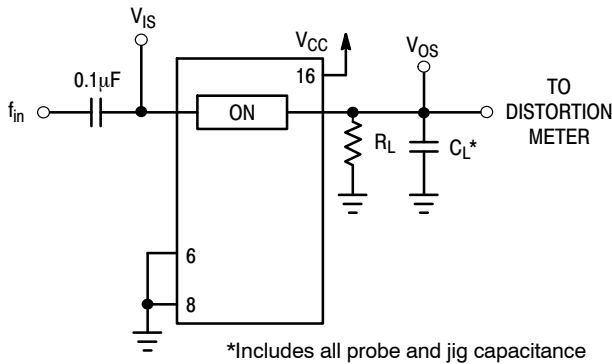


Figure 13. Power Dissipation Capacitance, Test Set-Up



\*Includes all probe and jig capacitance

Figure 14a. Total Harmonic Distortion, Test Set-Up

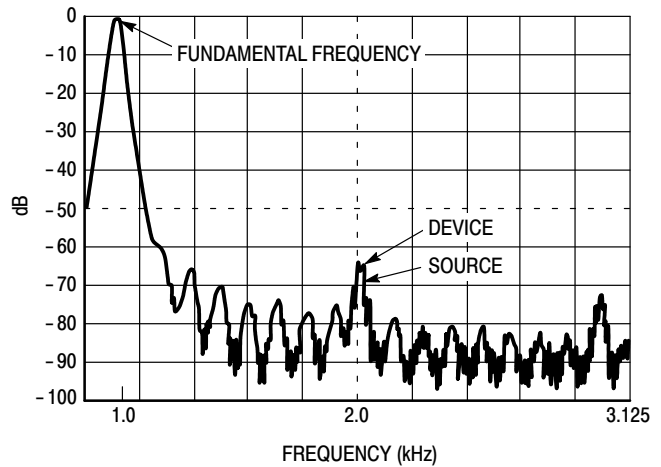


Figure 14b. Plot, Harmonic Distortion

## APPLICATIONS INFORMATION

The Channel Select and Enable control pins should be at  $V_{CC}$  or GND logic levels.  $V_{CC}$  being recognized as a logic high and GND being recognized as a logic low. In this example:

$$\begin{aligned} V_{CC} &= +5V = \text{logic high} \\ \text{GND} &= 0V = \text{logic low} \end{aligned}$$

The maximum analog voltage swing is determined by the supply voltage  $V_{CC}$ . The positive peak analog voltage should not exceed  $V_{CC}$ . Similarly, the negative peak analog voltage should not go below GND. In this example, the difference between  $V_{CC}$  and GND is five volts. Therefore, using the configuration of Figure 15, a maximum analog signal of five volts peak-to-peak can be controlled. Unused analog inputs/outputs may be left floating (i.e., not

connected). However, tying unused analog inputs and outputs to  $V_{CC}$  or GND through a low value resistor helps minimize crosstalk and feedthrough noise that may be picked up by an unused switch.

Although used here, balanced supplies are not a requirement. The only constraints on the power supplies are that:

$$V_{CC} - \text{GND} = 2 \text{ to } 6 \text{ volts}$$

When voltage transients above  $V_{CC}$  and/or below GND are anticipated on the analog channels, external Germanium or Schottky diodes ( $D_x$ ) are recommended as shown in Figure 16. These diodes should be able to absorb the maximum anticipated current surges during clipping.

# MC74LVXT8051

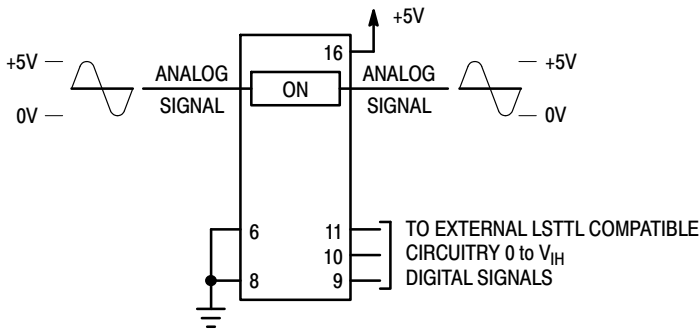


Figure 15. Application Example

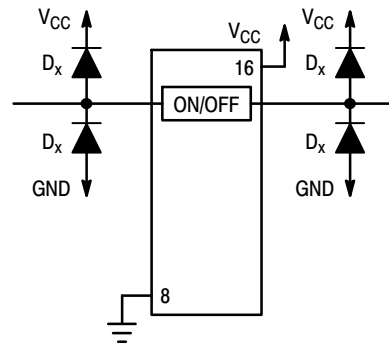
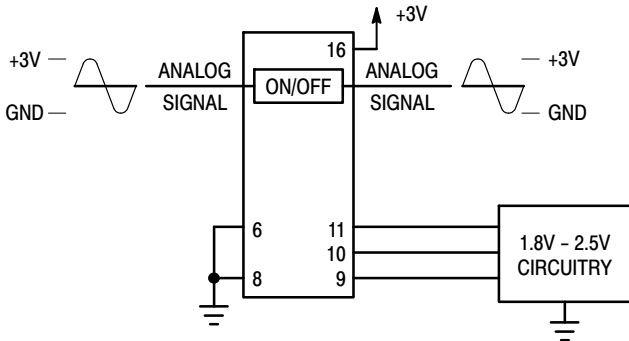
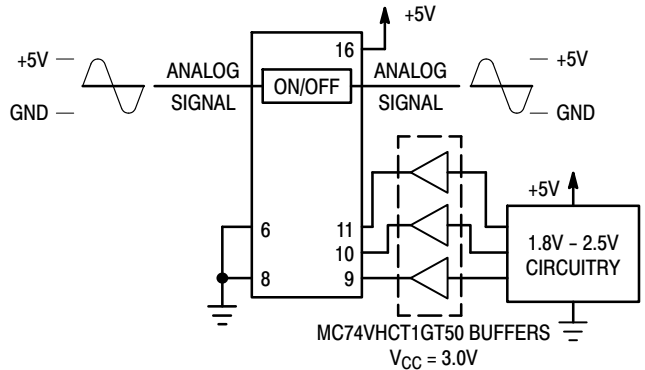


Figure 16. External Germanium or Schottky Clipping Diodes



a. Low Voltage Logic Level Shifting Control



b. 2-Stage Logic Level Shifting Control

Figure 17. Interfacing to Low Voltage CMOS Outputs

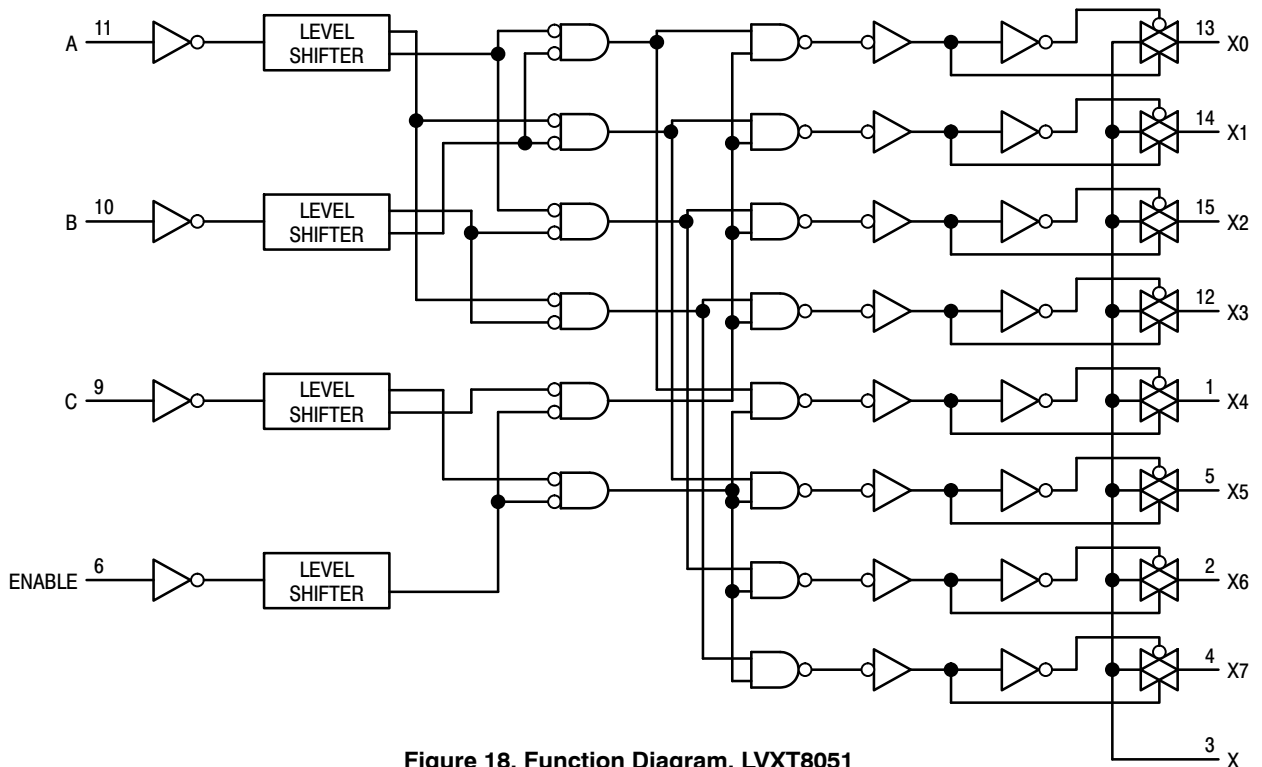


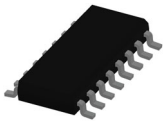
Figure 18. Function Diagram, LVXT8051

# MC74LVXT8051

## ORDERING INFORMATION

Device	Package	Shipping†
MC74LVXT8051DG	SOIC-16 (Pb-Free)	48 Units / Rail
MC74LVXT8051DR2G	SOIC-16 (Pb-Free)	2500 Tape & Reel
MC74LVXT8051DTR2G	TSSOP-16 (Pb-Free)	2500 Tape & Reel

†For information on tape and reel specifications, including part orientation and tape sizes, please refer to our Tape and Reel Packaging Specifications Brochure, [BRD8011/D](#).

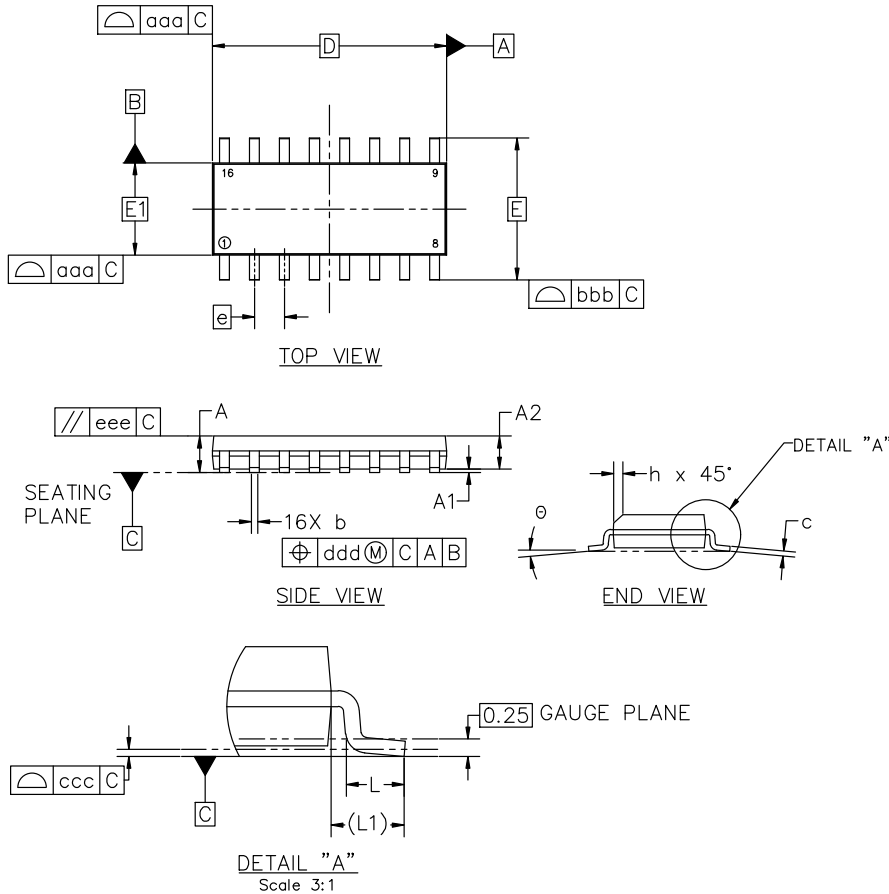


SOIC-16 9.90x3.90x1.37 1.27P  
CASE 751B  
ISSUE M

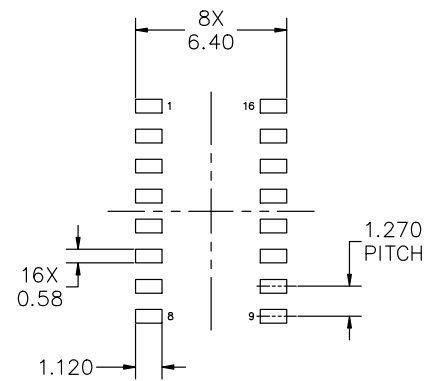
DATE 18 OCT 2024

NOTES:

1. DIMENSIONING AND TOLERANCING PER ASME Y14.5M, 2018.
2. DIMENSION IN MILLIMETERS. ANGLE IN DEGREES.
3. DIMENSIONS D AND E1 DO NOT INCLUDE MOLD PROTRUSION.
4. MAXIMUM MOLD PROTRUSION 0.15mm PER SIDE.
5. DIMENSION b DOES NOT INCLUDE DAMBAR PROTRUSION. ALLOWABLE DAMBAR PROTRUSION SHALL BE 0.127mm TOTAL IN EXCESS OF THE b DIMENSION AT MAXIMUM MATERIAL CONDITION.



MILLIMETERS			
DIM	MIN	NOM	MAX
A	1.35	1.55	1.75
A1	0.10	0.18	0.25
A2	1.25	1.37	1.50
b	0.35	0.42	0.49
c	0.19	0.22	0.25
D	9.90 BSC		
E	6.00 BSC		
E1	3.90 BSC		
e	1.27 BSC		
h	0.25	---	0.50
L	0.40	0.83	1.25
L1	1.05 REF		
θ	0°	---	7°
TOLERANCE OF FORM AND POSITION			
aaa	0.10		
bbb	0.20		
ccc	0.10		
ddd	0.25		
eee	0.10		



RECOMMENDED MOUNTING FOOTPRINT

\*FOR ADDITIONAL INFORMATION ON OUR PB-FREE STRATEGY AND SOLDERING DETAILS, PLEASE DOWNLOAD THE onsemi SOLDERING AND MOUNTING TECHNIQUES REFERENCE MANUAL, SOLDERRM/D

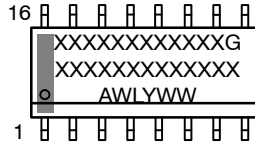
<b>DOCUMENT NUMBER:</b>	<b>98ASB42566B</b>	Electronic versions are uncontrolled except when accessed directly from the Document Repository. Printed versions are uncontrolled except when stamped "CONTROLLED COPY" in red.
<b>DESCRIPTION:</b>	<b>SOIC-16 9.90X3.90X1.37 1.27P</b>	<b>PAGE 1 OF 2</b>

onsemi and onsemi are trademarks of Semiconductor Components Industries, LLC dba onsemi or its subsidiaries in the United States and/or other countries. onsemi reserves the right to make changes without further notice to any products herein. onsemi makes no warranty, representation or guarantee regarding the suitability of its products for any particular purpose, nor does onsemi assume any liability arising out of the application or use of any product or circuit, and specifically disclaims any and all liability, including without limitation special, consequential or incidental damages. onsemi does not convey any license under its patent rights nor the rights of others.

SOIC-16 9.90x3.90x1.37 1.27P  
CASE 751B  
ISSUE M

DATE 18 OCT 2024

GENERIC  
MARKING DIAGRAM\*



XXXXX = Specific Device Code  
A = Assembly Location  
WL = Wafer Lot  
Y = Year  
WW = Work Week  
G = Pb-Free Package

\*This information is generic. Please refer to device data sheet for actual part marking. Pb-Free indicator, "G" or microdot "▪", may or may not be present. Some products may not follow the Generic Marking.

<p>STYLE 1:</p> <p>PIN 1. COLLECTOR  2. BASE  3. EMITTER  4. NO CONNECTION  5. EMITTER  6. BASE  7. COLLECTOR  8. COLLECTOR  9. BASE  10. EMITTER  11. NO CONNECTION  12. EMITTER  13. BASE  14. COLLECTOR  15. EMITTER  16. COLLECTOR</p>	<p>STYLE 2:</p> <p>PIN 1. CATHODE  2. ANODE  3. NO CONNECTION  4. CATHODE  5. CATHODE  6. NO CONNECTION  7. ANODE  8. CATHODE  9. CATHODE  10. ANODE  11. NO CONNECTION  12. CATHODE  13. CATHODE  14. NO CONNECTION  15. ANODE  16. CATHODE</p>	<p>STYLE 3:</p> <p>PIN 1. COLLECTOR, DYE #1  2. BASE, #1  3. EMITTER, #1  4. COLLECTOR, #1  5. COLLECTOR, #2  6. BASE, #2  7. EMITTER, #2  8. COLLECTOR, #2  9. COLLECTOR, #3  10. BASE, #3  11. EMITTER, #3  12. COLLECTOR, #3  13. COLLECTOR, #4  14. BASE, #4  15. EMITTER, #4  16. COLLECTOR, #4</p>	<p>STYLE 4:</p> <p>PIN 1. COLLECTOR, DYE #1  2. COLLECTOR, #1  3. COLLECTOR, #2  4. COLLECTOR, #2  5. COLLECTOR, #3  6. COLLECTOR, #3  7. COLLECTOR, #4  8. COLLECTOR, #4  9. BASE, #4  10. EMITTER, #4  11. BASE, #3  12. EMITTER, #3  13. BASE, #2  14. EMITTER, #2  15. BASE, #1  16. EMITTER, #1</p>
<p>STYLE 5:</p> <p>PIN 1. DRAIN, DYE #1  2. DRAIN, #1  3. DRAIN, #2  4. DRAIN, #2  5. DRAIN, #3  6. DRAIN, #3  7. DRAIN, #4  8. DRAIN, #4  9. GATE, #4  10. SOURCE, #4  11. GATE, #3  12. SOURCE, #3  13. GATE, #2  14. SOURCE, #2  15. GATE, #1  16. SOURCE, #1</p>	<p>STYLE 6:</p> <p>PIN 1. CATHODE  2. CATHODE  3. CATHODE  4. CATHODE  5. CATHODE  6. CATHODE  7. CATHODE  8. CATHODE  9. ANODE  10. ANODE  11. ANODE  12. ANODE  13. ANODE  14. ANODE  15. ANODE  16. ANODE</p>	<p>STYLE 7:</p> <p>PIN 1. SOURCE N-CH  2. COMMON DRAIN (OUTPUT)  3. COMMON DRAIN (OUTPUT)  4. GATE P-CH  5. COMMON DRAIN (OUTPUT)  6. COMMON DRAIN (OUTPUT)  7. COMMON DRAIN (OUTPUT)  8. SOURCE P-CH  9. SOURCE P-CH  10. COMMON DRAIN (OUTPUT)  11. COMMON DRAIN (OUTPUT)  12. COMMON DRAIN (OUTPUT)  13. GATE N-CH  14. COMMON DRAIN (OUTPUT)  15. COMMON DRAIN (OUTPUT)  16. SOURCE N-CH</p>	

<b>DOCUMENT NUMBER:</b>	98ASB42566B	Electronic versions are uncontrolled except when accessed directly from the Document Repository. Printed versions are uncontrolled except when stamped "CONTROLLED COPY" in red.
<b>DESCRIPTION:</b>	SOIC-16 9.90X3.90X1.37 1.27P	<b>PAGE 2 OF 2</b>

onsemi and Onsemi are trademarks of Semiconductor Components Industries, LLC dba onsemi or its subsidiaries in the United States and/or other countries. onsemi reserves the right to make changes without further notice to any products herein. onsemi makes no warranty, representation or guarantee regarding the suitability of its products for any particular purpose, nor does onsemi assume any liability arising out of the application or use of any product or circuit, and specifically disclaims any and all liability, including without limitation special, consequential or incidental damages. onsemi does not convey any license under its patent rights nor the rights of others.

**onsemi**, **Onsemi**, and other names, marks, and brands are registered and/or common law trademarks of Semiconductor Components Industries, LLC dba "**onsemi**" or its affiliates and/or subsidiaries in the United States and/or other countries. **onsemi** owns the rights to a number of patents, trademarks, copyrights, trade secrets, and other intellectual property. A listing of **onsemi**'s product/patent coverage may be accessed at [www.onsemi.com/site/pdf/Patent-Marking.pdf](http://www.onsemi.com/site/pdf/Patent-Marking.pdf). **onsemi** reserves the right to make changes at any time to any products or information herein, without notice. The information herein is provided "as-is" and **onsemi** makes no warranty, representation or guarantee regarding the accuracy of the information, product features, availability, functionality, or suitability of its products for any particular purpose, nor does **onsemi** assume any liability arising out of the application or use of any product or circuit, and specifically disclaims any and all liability, including without limitation special, consequential or incidental damages. Buyer is responsible for its products and applications using **onsemi** products, including compliance with all laws, regulations and safety requirements or standards, regardless of any support or applications information provided by **onsemi**. "Typical" parameters which may be provided in **onsemi** data sheets and/or specifications can and do vary in different applications and actual performance may vary over time. All operating parameters, including "Typicals" must be validated for each customer application by customer's technical experts. **onsemi** does not convey any license under any of its intellectual property rights nor the rights of others. **onsemi** products are not designed, intended, or authorized for use as a critical component in life support systems or any FDA Class 3 medical devices or medical devices with a same or similar classification in a foreign jurisdiction or any devices intended for implantation in the human body. Should Buyer purchase or use **onsemi** products for any such unintended or unauthorized application, Buyer shall indemnify and hold **onsemi** and its officers, employees, subsidiaries, affiliates, and distributors harmless against all claims, costs, damages, and expenses, and reasonable attorney fees arising out of, directly or indirectly, any claim of personal injury or death associated with such unintended or unauthorized use, even if such claim alleges that **onsemi** was negligent regarding the design or manufacture of the part. **onsemi** is an Equal Opportunity/Affirmative Action Employer. This literature is subject to all applicable copyright laws and is not for resale in any manner.

---

## ADDITIONAL INFORMATION

### TECHNICAL PUBLICATIONS:

Technical Library: [www.onsemi.com/design/resources/technical-documentation](http://www.onsemi.com/design/resources/technical-documentation)  
onsemi Website: [www.onsemi.com](http://www.onsemi.com)

### ONLINE SUPPORT: [www.onsemi.com/support](http://www.onsemi.com/support)

For additional information, please contact your local Sales Representative at [www.onsemi.com/support/sales](http://www.onsemi.com/support/sales)